

# UNIT 1 BONDING, FUNCTIONAL GROUP CLASSIFICATION AND NOMENCLATURE

---

## Structure

- 1.1 Introduction
    - Objectives
  - 1.2 The Covalent Bond
  - 1.3 Structural Formulas
  - 1.4 Orbital Hybridisation
    - $sp^3$ -Hybridisation
    - $sp^2$ -Hybridisation
    - $sp$ -Hybridisation
  - 1.5 Functional Group Classification
  - 1.6 Nomenclature of Organic Compounds
  - 1.7 Summary
  - 1.8 Terminal Questions
  - 1.9 Answers
- 

## 1.1 INTRODUCTION

---

Organic Chemistry is a highly organised discipline. It is the study of the relationship between the structures of molecules and their reactions. We will begin our study with the type of bonding and structural aspects of the molecules. You are already familiar from Unit 3, Block 1 of the Atoms and Molecules course that the compounds can be broadly divided into two classes, ionic and covalent. Ionic compounds are composed of positively and negatively charged ions which are held together by electrostatic forces. Since ions can be regarded as spheres having symmetrical distribution of charge, no particular direction can be assigned to such type of bonding. For example, in NaCl lattice,  $\text{Na}^+$  and  $\text{Cl}^-$  ions are held together by electrostatic forces; no  $\text{Na}^+$  ion can be regarded as bonded to a particular  $\text{Cl}^-$  ion. In other words, there is no such entity which can be called as NaCl molecule. In fact, the electrostatic forces operate between a particular ion ( $\text{Na}^+$ ) and all its neighbouring ions ( $\text{Cl}^-$ ) of opposite charge. On the other hand, in covalent compounds, molecules are the structural units. In contrast to the ionic compounds, in covalent compounds, the molecules are formed by the sharing of electron pair(s) between the constituent atoms. The bonds formed by sharing of pair(s) of electrons are called covalent bonds. Since in organic compounds, the bonds formed by carbon atom are covalent in nature, we will study some features of the covalent bonding in detail. We will then explain shapes of molecules using the concept of hybridisation. We shall also learn various types of functional groups present in organic compounds and classify these compounds into various classes on the basis of the functional groups. Finally, we will study, how to name the compounds belonging to various classes.

### Objectives

After studying this unit, you should be able to :

- describe general features of a covalent bond,
  - define bond length, bond angle and bond energy,
  - explain various types of hybridisation of carbon compounds,
  - identify the functional groups present in a molecule,
  - give IUPAC names of various compounds belonging to different classes, and
  - write the correct structure of a compound from its name.
- 

## 1.2 THE COVALENT BOND

---

The sharing of electrons to form a covalent bond leads to an increase in electron

density in between the nuclei. In such an arrangement, the forces holding the atoms together are also electrostatic in nature; but this time the forces operate between the electrons of one atom and the nucleus of the other. Such a system has lower energy and is more stable as compared to the energy of isolated atoms. It is so because each electron is now attracted by two nuclei. As a result, the formation of the bond is accompanied by the release of the energy. The same amount of energy has to be supplied to break that particular bond. The amount of energy required to break a particular bond (expressed in terms of  $\text{kJ mol}^{-1}$ ) is called its **bond dissociation energy**. You should not confuse **bond dissociation energy** with another term **bond energy** which is an **average** value for a particular bond. The difference in these two energies can be illustrated by taking the example of methane,  $\text{CH}_4$ . If the C-H bonds are successively broken as shown below, then the bond dissociation energy for each step is as indicated on the right hand side.

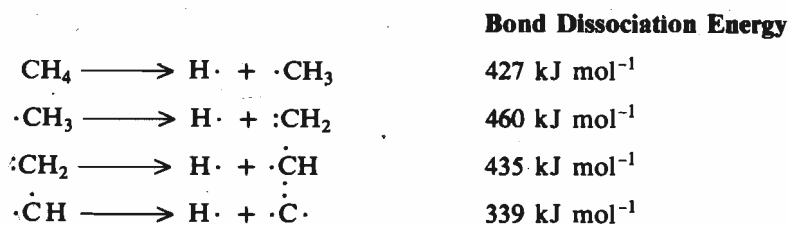

You can see from these values that the dissociation energies are **different** for each C-H bond breakage. On the other hand, **bond energy** is a single average value which can be obtained as,

$$\begin{aligned} \text{Bond energy of the C-H bond} &= \frac{427 + 460 + 435 + 339}{4} \text{ kJ mol}^{-1} \\ &= \frac{1661}{4} \text{ kJ mol}^{-1} = 415.25 \text{ kJ mol}^{-1} \end{aligned}$$

Thus, the C-H bond energy in methane is one-fourth of the energy required for the following change.



Clearly, if the molecule is diatomic, then bond dissociation energy and bond energy are the same. Generally, bond dissociation energy values are more useful. Table 1.1 lists the bond energies and bond dissociation energies for some bonds in  $\text{kJ mol}^{-1}$  (at 298 K and 1 atm. pressure).

Table 1.1 : Bond Energy and Bond Dissociation Energy Values in  $\text{kJ mol}^{-1}$

Bond	Bond Energy	Bond	Bond Energy	Bond	Bond Dis- sociation Energy	Bond	Bond Dis- sociation Energy
H-H	436	N-N	163	$\text{CH}_3\text{-H}$	427	Ph-OH	431
F-F	158	N=N	409	$\text{CH}_3\text{CH}_2\text{-H}$	418	Ph-NH <sub>2</sub>	381
Cl-Cl	242	N≡N	945	$\text{CH}_3\text{CH}_2\text{CH}_2\text{-H}$	410	Ph-F	485
Br-Br	193	O-H	463	$(\text{CH}_3)_2\text{CH-H}$	395.5	Ph-Cl	406
I-I	151	O-O	146	$(\text{CH}_3)_3\text{C-H}$	381	Ph-Br	301
H-F	565	O=O	497	$\text{CH}_3\text{-CH}_3$	368	Ph-I	272
H-Cl	426.8	C-O	334.7	$\text{CH}_3\text{-F}$	451		
H-Br	364	C=O	694.5	$\text{CH}_3\text{-Cl}$	349		
H-I	297.1	O=C=O	803.3	$\text{CH}_3\text{-Br}$	293		
C-H	414	C-N	284.5	$\text{CH}_3\text{-I}$	234		
C-F	484	C=N	615.1	HO-H	498		
C-Cl	338	C≡N	866.1	$\text{CH}_3\text{O-H}$	427		
C-Br	276	N-H	389.1	$\text{CH}_3\text{-OH}$	383		
C-I	238	N-O	200.8	Ph-H	431		
C-C	348	N=O	606.7	PhCH <sub>2</sub> -H	356		
C=C	612	S-H	347.3	Ph-CH <sub>3</sub>	389		
C≡C	813	S-S	225.9	PhO-H	356		
		S=O	497.9				

There are two more parameters associated with a covalent bond which determine the shape of a molecule and are known as **bond length** and **bond angle**. Bond length can be defined as the average distance between the nuclei of the atoms which are covalently bound together. Bond angle can be defined as the angle between the atoms, forming the bonds to the same atom. Table 1.2 gives the bond lengths for some of the bonds.

Table 1.2 : Bond lengths for some of the bonds

Bond	Bond length/pm	Bond	Bond length/pm
H-H	74	C-F	142
C-H	112	C-Cl	177
C-C	154	C-Br	191
C=C	134	C-I	213
C≡C	120	C-O	143
F-F	144	C=O	120
Cl-Cl	198	N-H	103
Br-Br	228	N-N	147
I-I	266	N=N	130
C-C in C <sub>6</sub> H <sub>6</sub>	139	C=N	130
O-H	97	C≡N	110

1 pm = 1 picometer  
 = 10<sup>-12</sup> m

From these values of bond lengths, we can conclude that :

- bond length decreases with the increase in multiplicity of the bond. Thus, the decreasing order for bond lengths for carbon-carbon bonds is  
 $C-C > C=C > C\equiv C$ .
- bond lengths increase with the increasing size of the bonded atoms, i.e., the increasing order of bond lengths is  $C-H < C-F < C-Cl < C-Br < C-I$ .

We will study more about bond lengths and bond angles later in Sec. 1.4, when we discuss hybridisation. You will see in the later units in this course how important these parameters of a bond are in deciding the chemical reactivity of a compound. Before proceeding further, let us study something about how the structures for the organic compounds are written.

### 1.3 STRUCTURAL FORMULAS

Structural formula of a compound is its Lewis structure, which shows how various atoms are connected to each other. You are already familiar with Lewis structures of some of the compounds from your study of Unit 3, Block 1 of Atoms and Molecules course. Some examples are :

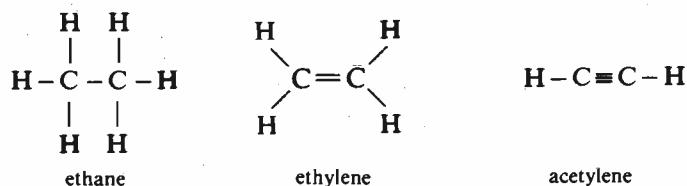

To save space and time, these structures are represented by **condensed formulas** which do not show the bonds. For example, the condensed formula for ethane can be written as CH<sub>3</sub>CH<sub>3</sub>.

Similarly, we can write condensed structural formula for

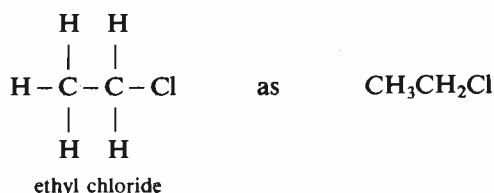

Remember that all the representations of the formulas are in two dimensions but actually molecules are three-dimensional in nature. About this, you will study in Units 2 and 3 in detail.

and for

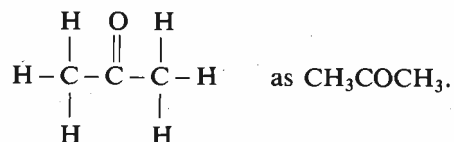

acetone

Repeating units such as  $(-\text{CH}_2-)$  in the structural formula can be enclosed in brackets and hence hexane

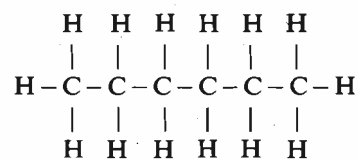

hexane

can be written as  $\text{CH}_3(\text{CH}_2)_4\text{CH}_3$ .

Condensed formulas for compounds having multiple bonds can be written as shown below:

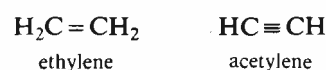

For simple compounds, it is easy to write the condensed formulas. But, when the molecules are complex, these formulas look rather awkward and can be further abbreviated. These representations, are called **line** or **skeletal** structures. Here, the hydrogens are not shown and **each end** and **bends** represent the carbon atoms as shown below for some cases:

The skeletal structures or line structures show only the carbon-carbon bonds.

**Compound**

pentane

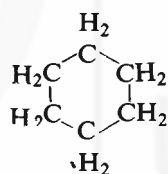
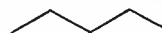
**Line structure**

cyclohexane

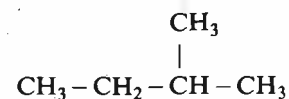

2-methylbutane

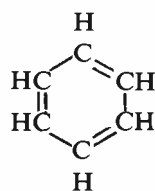
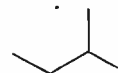

benzene



Having understood the above representations, answer the following SAQ.

**SAQ 1**

Write the condensed formulas for the following compounds:

a)

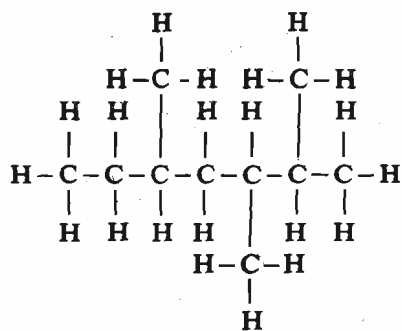

b)

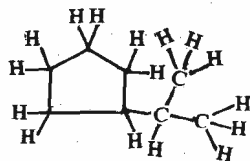

## 1.4 ORBITAL HYBRIDISATION

Properties and chemical reactions of most organic molecules can be easily explained by considering the molecules to be formed by sharing of electron pairs between the atoms. Another approach to formation of molecules which you studied in Unit 5 of Block 1 in Atoms and Molecules course, is the molecular orbital method. Organic chemists have for many years employed a bonding model that combines elements of molecular orbital theory with Lewis model of formation of covalent bond by electron sharing. This model was proposed by Pauling in 1930 and is based on the concept of **orbital hybridisation**. This model uses the terminology of molecular orbital theory but treats the bonds between the atoms as though they are localised, as in the case of diatomic molecules. In other words, it is a sort of **localised molecular orbital treatment of the bond**.

You have already studied in Unit 4, Block 1 of Atoms and Molecules course that various types of orbital hybridisation is possible depending upon the number and nature of the orbitals involved. In this unit, we will restrict our discussion to the hybridisation involving *s* and *p* orbitals. Let us now study each type of hybridisation involving *s* and *p* orbitals, in detail, to understand this concept and its use in explaining the formation of molecules.

### 1.4.1 *sp*<sup>3</sup>-Hybridisation

Let us consider the simplest organic compound, methane, having the molecular formula CH<sub>4</sub>. You can recall that carbon has the electron configuration 1s<sup>2</sup> 2s<sup>2</sup> 2p<sub>x</sub><sup>1</sup> 2p<sub>y</sub><sup>1</sup>. Since only two unpaired electrons are there, one may expect that it should form only two bonds with two hydrogens to form CH<sub>2</sub>. But actually it forms four bonds with four hydrogens to give CH<sub>4</sub>. Pauling proposed that this could be explained by using orbital hybridisation. In this method, atomic orbitals are mixed to yield the new hybrid orbitals. In this case, in the first step one of the 2s electrons is promoted to the 2p<sub>z</sub> orbital, electron configuration can then be written as 2s<sup>1</sup> 2p<sub>x</sub><sup>1</sup> 2p<sub>y</sub><sup>1</sup> 2p<sub>z</sub><sup>1</sup>. Bond formation with these pure atomic orbitals would lead to the situation where the bond formed by one 2s electron will be different from the bonds formed by three 2p electrons. But, in methane molecule, all the four bonds are equivalent. In order to explain this, the idea of orbital

Hybridisation is a theoretical concept which enables as realistic modelling of molecular structure as possible.

The orbitals which undergo hybridisation, should not be energetically much different.

The number of hybrid orbitals generated is always equal to the number of atomic orbitals combined.

*sp*<sup>3</sup> is pronounced as *s-p*-three and not *sp* cube.

The hybrid orbitals are obtained by mathematical combinations of atomic orbitals.

**Fundamental Concepts**

Hybridisation may not always yield *equivalent* hybrid orbitals. You are already familiar from Unit 4 of Atoms and Molecules course that in  $sp^3d$  hybridisation two kinds of hybrid orbitals are obtained.

hybridisation was invoked. In this process, one 2s and three 2p orbitals on hybridisation yield a set of four new equivalent orbitals. These new orbitals are called **hybrid orbitals**. Since they are formed by combining one s and three p orbitals, they are called  $sp^3$  hybrid orbitals. All the four  $sp^3$  hybrid orbitals are of

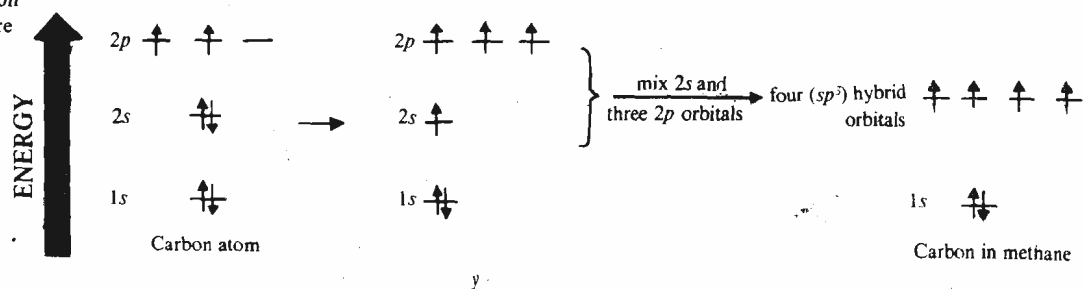

equal energy and each one of them has 25% s character and 75% p character.

These  $sp^3$  hybrid orbitals are shown in Fig. 1.1. You can see in Fig. 1.1(a) that the

Like pure atomic orbitals, the hybrid orbitals also represent the region of space where there is some finite probability of finding an electron.

The tetrahedral shape is one of the most stable structures. This is reflected in case of diamond which is the hardest known substance. The structure of diamond (see Fig. 3.8, Sec. 3.4, Unit 3, Block 1 of Atoms and Molecules course) shows the tetrahedral carbon atoms linked together.

The tetrahedral concrete structures are used for checking sea-erosion as shown in the following picture:

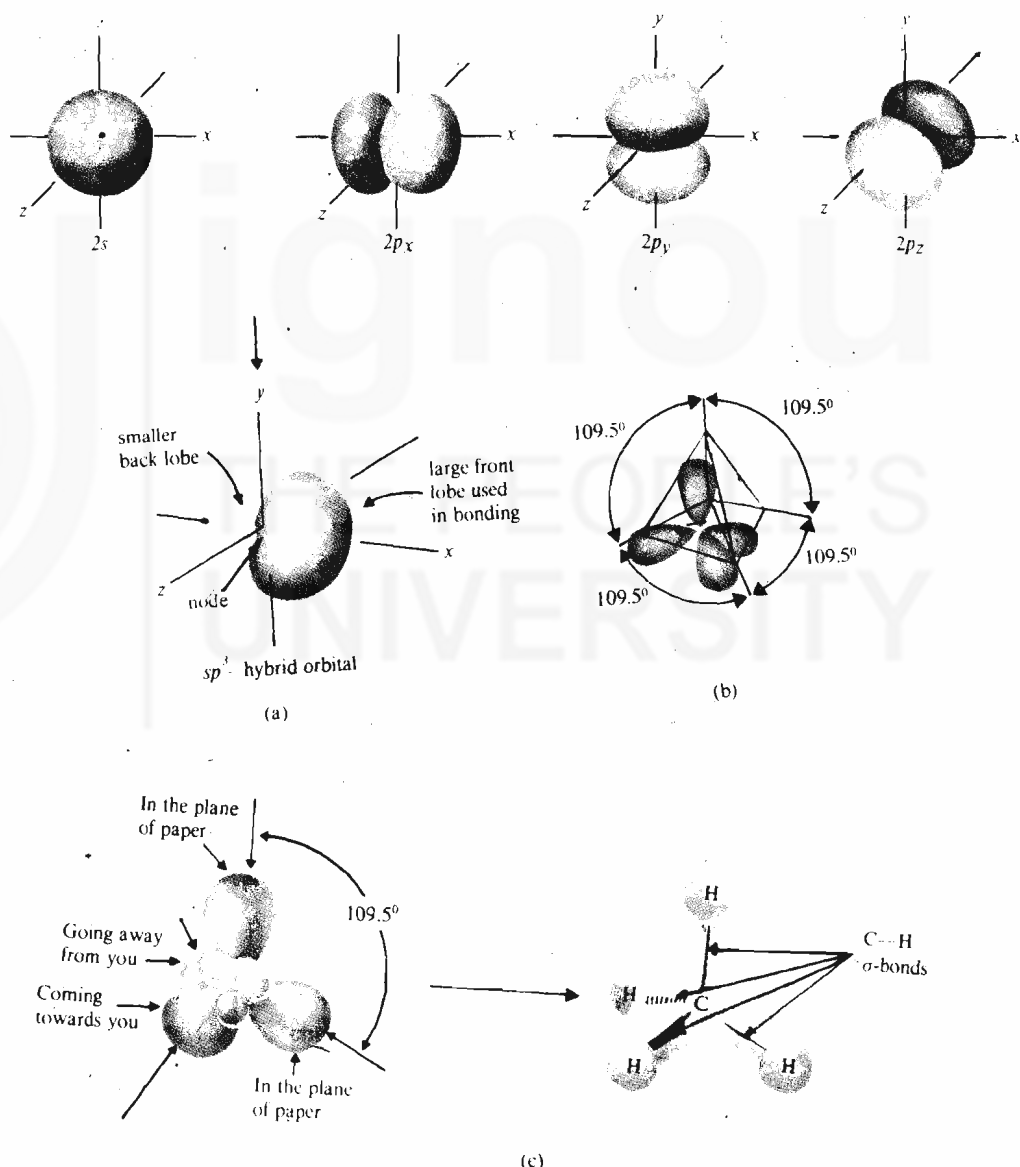

Fig. 1.1 : a) Hybridisation of one 2s and three 2p orbitals to yield four  $sp^3$  hybrid orbitals. b) Four  $sp^3$  hybrid orbitals directed towards the corners of a tetrahedron; small back lobes are not shown. c) Formation of methane molecule.

Remember that hybridisation involves mixing of orbitals of the one and the same atom and not the orbitals of different atoms.

$sp^3$  hybrid orbital has two lobes of unequal size separated from each other by a node. This situation is similar to a  $p$  orbital but with the difference that here one lobe is very small and the other is very large. In other words, in  $sp^3$  hybrid orbitals, the electron density is concentrated in one direction which leads to greater overlap as compared to pure atomic orbitals. Hence, the bonds formed by such orbitals will be stronger and more stable in comparison to those formed by using pure atomic orbitals. The spatial orientation of these orbitals is obtained by mathematical calculations and is shown in Fig. 1.1(b). This is in accordance with the VSEPR theory which you studied in Unit 3, Block 1 of Atoms and Molecules course. You can see in the figure that these orbitals are directed towards the corners of a tetrahedron and the bond angle between any two  $sp^3$  hybrid orbitals is  $109.5^\circ$ . In methane molecule, each of the four  $sp^3$  hybrid orbitals overlaps with  $1s$  orbital of four hydrogens as shown in Fig. 1.1(c).

Note that the bonds so formed, i.e., the C–H bonds, are  $\sigma$  (sigma) bonds. If instead of combining with hydrogens, the hybrid orbital forms a bond with the similar hybrid orbital of another carbon atom, then a C–C bond will result instead of the C–H bond. The C–C bond has a bond length of 154 pm and a bond energy of  $348 \text{ kJ mol}^{-1}$ . You will study more about the compounds involving  $sp^3$  hybridisation in Unit 6 of Block 2 of this course.

### 1.4.2 $sp^2$ -Hybridisation

In a molecule like ethylene, where there are not enough hydrogens in the molecule to form six C–H bonds, another type of hybridisation has to be thought of.

In this type of hybridisation, as the name indicates, the  $2s$  orbital of the carbon is hybridised with *only two* of the three available  $2p$  orbitals, as shown below.

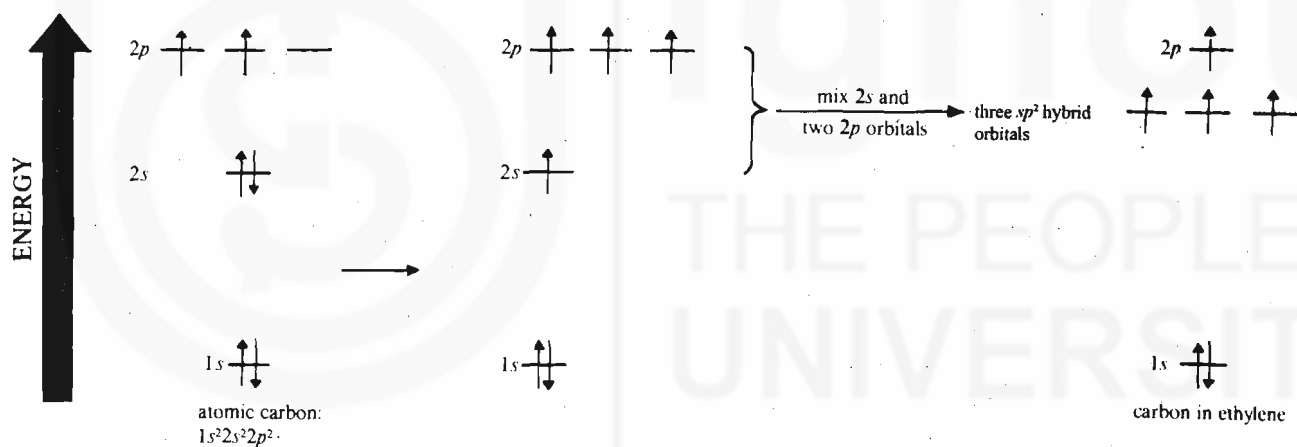

Since three orbitals are hybridised, three equivalent  $sp^2$  hybrid orbitals are obtained. We shall now explain  $sp^2$  hybridisation using ethylene as an example. According to the VSEPR theory, these orbitals are oriented in space making an angle of  $120^\circ$  with each other as shown in Fig. 1.2(a). Note that the three  $sp^2$  hybrid orbitals are in one plane. The third  $p$  orbital which is not utilised for hybridisation is perpendicular to the  $sp^2$  hybrid orbitals and is shown in red colour in Fig. 1.2(a).

When two such  $sp^2$  hybridised carbon atoms form a bond, the C–C bond formed is again a  $\sigma$  bond. If the rest of the  $sp^2$  hybrid orbitals on each carbon atom overlap with  $1s$  orbital of the two hydrogen atoms, then as shown in Fig. 1.2(b), the two unhybridised  $p$  orbitals on the two carbon atoms are parallel to each other. These  $p$  orbitals can overlap sideways to yield a second bond, known as  $\pi$  (pi) bond which is shown in Fig. 1.2(c). The C=C bond length for ethylene molecule so obtained is 134 pm. You can compare this value with C–C single bond length as given before in case of ethane. You will study in detail, the compounds having  $sp^2$  hybridised carbon atoms such as **alkenes** and **dienes** in Unit 7 of Block 2.

**Fundamental Concepts**

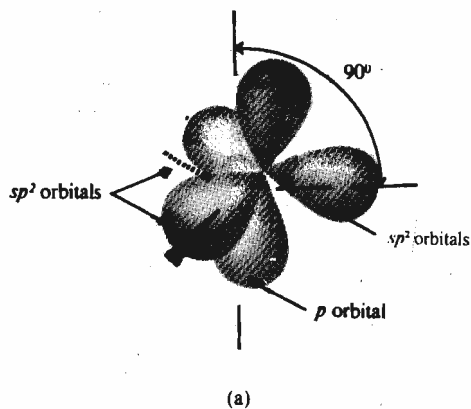

You are aware that:

- i)  $\sigma$  bonds are formed by the edge-on overlap of pure ( $s$  and  $p$ ) or hybrid orbitals. The electron density in  $\sigma$  bonds is maximum along the internuclear axis.
- ii)  $\pi$  bonds are formed by sideways overlap of  $p$  orbitals.  $\pi$  bonds have maximum electron density above and below the internuclear axis.

**Activity**

Make a model of ethylene molecule and convince yourself that it is flat in shape with the two carbons and their substituent hydrogens lying in one plane. However, the  $\pi$  bond is at right angles to this plane.

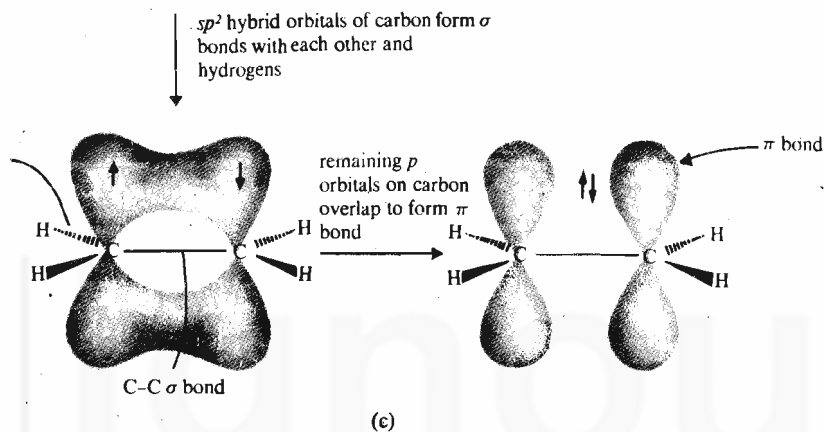
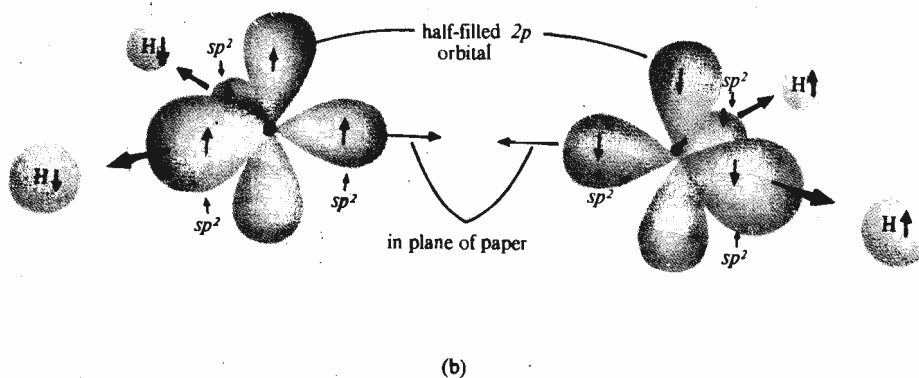

Fig. 1.2 : a)  $sp^2$  hybrid orbitals. b) Formation of C-C  $\sigma$  bond. c) Formation of a  $\pi$  bond in ethylene molecule.

**SAQ 2**

Predict the percentage of  $s$  and  $p$  character in  $sp^2$  hybrid orbitals.

.....

.....

**1.4.3  $sp$ -Hybridisation**

Let us now consider the third type of hybridisation involving  $s$  and  $p$  orbitals in cases where a triple bond is stipulated. In carbon atom when  $2s$  and *only one* of the three  $2p$  orbitals hybridise as shown below, the hybridisation is known as  $sp$ -

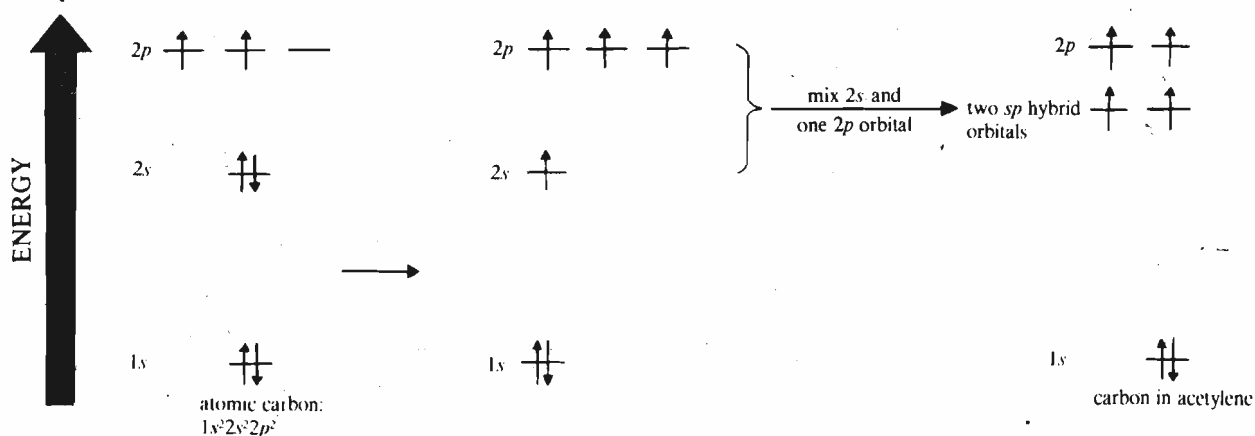



hybridisation. This leads to two new equivalent  $sp$  hybrid orbitals as shown in Fig. 1.3(a). These two orbitals are oriented in space at an angle of  $180^\circ$  according

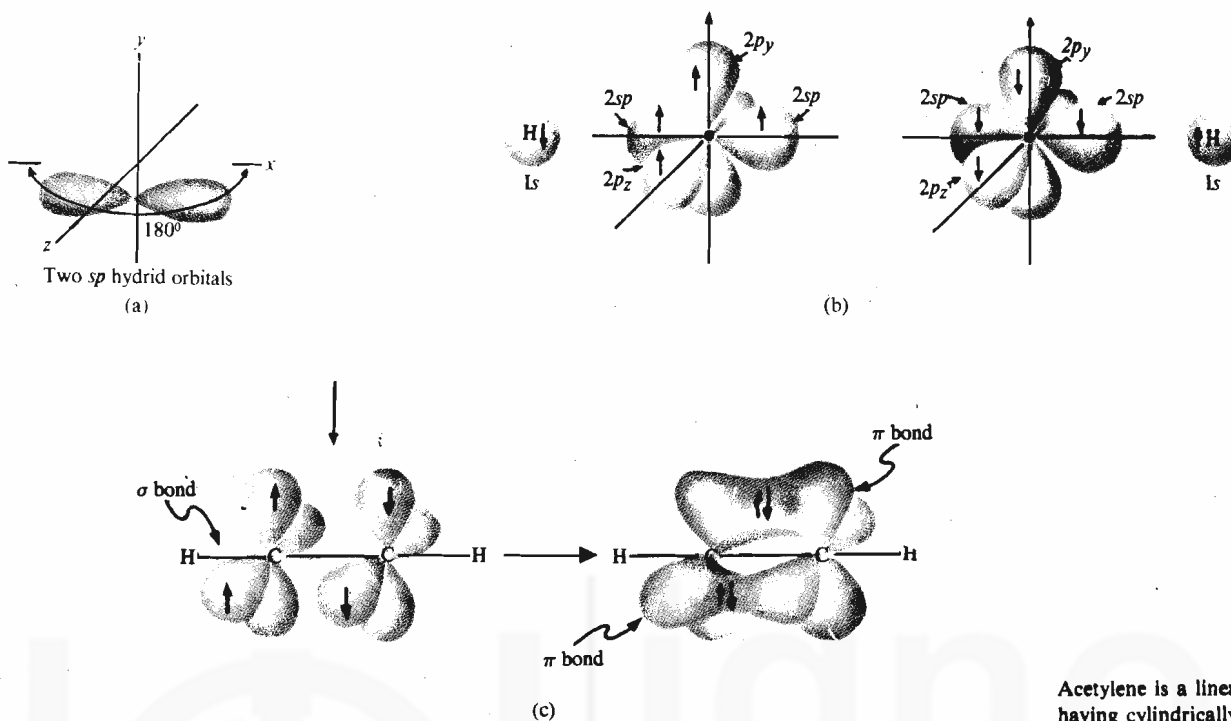

Acetylene is a linear molecule having cylindrically symmetrical  $\pi$  electron density about the internuclear axis.

Fig. 1.3 : a) Two  $sp$  hybrid orbitals. b) Formation of one  $\sigma$  (sigma) bond. c) Formation of two  $\pi$  bonds in acetylene molecule.

to the VSEPR theory. Let us study  $sp$ -hybridisation using acetylene as an example. When one of the two  $sp$  hybrid orbitals on each carbon atom combines with another, a C–C sigma bond is formed. The second  $sp$  hybrid orbital on each carbon forms a sigma bond with  $1s$  orbitals of two hydrogens, as shown in Fig. 1.3(b). This leaves two  $p$  orbitals on each carbon atom which are not used in  $sp$  hybridisation. These  $p$  orbitals are perpendicular to each other and also to the sigma bond. These  $p$  orbitals can overlap laterally to give rise to two  $\pi$  bonds. Such a bond is called a triple bond and we get the acetylene molecule, as shown in Fig. 1.3(c). The  $C\equiv C$  bond in acetylene has a bond length of 120 pm and the  $H-C-C$  angle is  $180^\circ$  which shows that it is linear. Compounds having triple bond are called **alkynes** and will be dealt with in detail in Unit 8 of Block 2. We can sum up the above information as shown in Table 1.3.

Table 1.3 : Bond characteristics and hybridisation of carbon in simple molecules

Compound	Hybridisation of carbon atom	Bond length in pm	Bond angle	Nature of carbon-carbon bonds
Ethane	$sp^3$	154	$109.5^\circ$	single
Ethylene	$sp^2$	134	$120^\circ$	double
Acetylene	$sp$	120	$180^\circ$	triple

From the data given in the Table 1.3 we can conclude that

- in the hybrid orbitals, as the  $s$  character increases, bond length decreases.
- as the bond order increases, the bond length decreases.

Before proceeding to the next section, answer the following SAQ.

## SAQ 3

Indicate the type of hybridisation for each of the carbon atoms in the following compounds:

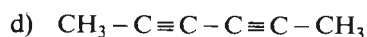
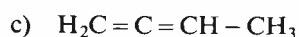
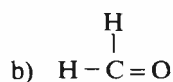
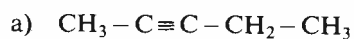

## 1.5 FUNCTIONAL GROUP CLASSIFICATION

A systematic study of chemistry or for that matter any other branch of science, is not possible without arranging the subject matter in a logical manner when sufficient data has accumulated. In case of inorganic chemistry, formulation of the periodic table stimulated not only the search for missing elements but also led to the understanding of the periodic behaviour. In organic chemistry, as the number of known organic compounds runs into millions, it is very difficult to study each and every compound individually. Thus, by grouping similar compounds together in a class or a family, it is easier to understand their properties, reactions etc. One way of such classification is based on the **functional groups**. A *functional group* can be defined as an atom or a group of atoms in a molecule which exhibits characteristic chemical properties. Such chemical properties exhibited by the functional group are more or less constant for various compounds having different carbon chains. Indeed, many organic reactions involve transformation of the functional group and do not affect the rest of the molecule. The advantage of such a classification based on functional groups is that in addition to logically systematising the organic compounds, the properties of the compounds can be predicted just by looking at their structures, i.e., by knowing the type of functional group present. Table 1.4 lists a number of important functional groups. You will study each class of compounds in detail in the forthcoming blocks of this course.

Table 1.4 : Functional Groups

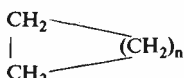
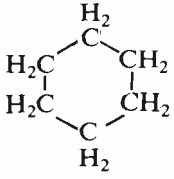
Class	Functional Group	General structural formula	Example	IUPAC suffix or prefix
<i>Containing C and H only</i>				
Alkane	none	R-H	$\text{CH}_4$ methane	-ane
Alkene		$\begin{array}{c} \text{R} \quad \text{R}_2 \\ \diagdown \quad / \\ \text{C} = \text{C} \\ / \quad \diagdown \\ \text{R}_1 \quad \text{R}_3 \end{array}$	$\text{H}_2\text{C} = \text{CH}_2$ ethylene	-ene
Alkyne	$-\text{C} \equiv \text{C}-$	$\text{R} - \text{C} \equiv \text{C} - \text{R}_1$	$\text{H} - \text{C} \equiv \text{C} - \text{H}$ acetylene	-yne
Cycloalkane	none		 cyclohexane (n = 4)	cyclo- ... -ane

Aromatic Compounds				—
			benzene	
<i>Containing C, H and O</i>				
Alcohol	-OH	R-OH	CH <sub>3</sub> -OH methanol	-ol
Phenol		Ar-OH	 phenol	-ol
Ether	-O-	R-OO-R'	CH <sub>3</sub> -O-CH <sub>3</sub> dimethyl ether	alkoxy-
<i>Carbonyl compounds</i>				
Aldehyde		RCHO	CH <sub>3</sub> CHO acetaldehyde	-al
Ketone		R-C(=O)-R'	CH <sub>3</sub> -C(=O)-CH <sub>3</sub> acetone	-one
Carboxylic acid		R-C(=O)-OH	CH <sub>3</sub> -C(=O)-OH acetic acid	-oic acid
Ester		R-C(=O)-OR'	CH <sub>3</sub> -C(=O)-O-CH <sub>3</sub> methyl acetate	-oate
Anhydride		R-C(=O)-O-C(=O)-R'	CH <sub>3</sub> -C(=O)-O-C(=O)-CH <sub>3</sub> acetic anhydride	-oic anhydride
<i>Containing C, H and N</i>				
Amine		R-NH <sub>2</sub> (primary amine)	CH <sub>3</sub> NH <sub>2</sub> methylamine	-amine or Amino-
		R'-NH <sub>2</sub> (secondary amine)	CH <sub>3</sub> -NH-CH <sub>3</sub> dimethylamine	
		R'-N-R'' (tertiary amine)	CH <sub>3</sub> -N(CH <sub>3</sub> ) <sub>2</sub> trimethylamine	
Imine		R-C(=N-R'')	N-CH <sub>3</sub> H <sub>3</sub> C-C(=N)-H <i>N</i> -ethylidene-methylamine	—
Nitrile	-C≡N	R-C≡N	CH <sub>3</sub> -C≡N acetonitrile	- nitrile
<i>Containing C, H, N and O</i>				
Nitro compounds	-NO <sub>2</sub>	R-NO <sub>2</sub>	CH <sub>3</sub> -NO <sub>2</sub> nitromethane	Nitro-
Amide		R-C(=O)-NH <sub>2</sub>	CH <sub>3</sub> -C(=O)-NH <sub>2</sub> acetamide	- amide

Containing C, H and other elements

Halide	-X	R-X	CH <sub>3</sub> -Cl methyl chloride	Halo-
Acyl halide	$\begin{array}{c} \text{O} \\ \parallel \\ -\text{C}-\text{X} \end{array}$	$\begin{array}{c} \text{O} \\ \parallel \\ \text{R}-\text{C}-\text{X} \end{array}$	$\begin{array}{c} \text{O} \\ \parallel \\ \text{CH}_3-\text{C}-\text{Cl} \end{array}$ acetyl chloride	-oyl halide
Thiol	-SH	R-SH	CH <sub>3</sub> -SH methanethiol	-thiol
Sulphonic acid	-SO <sub>2</sub> -OH	R-SO <sub>2</sub> -OH	CH <sub>3</sub> -SO <sub>2</sub> -OH methanesulphonic acid	-sulphonic acid

\*Here, X stands for halogens (F, Cl, Br and I), R stands for the alkyl group and Ar stands for the aryl group.

\*The names given in Column 4 are common names.

\*At this stage, you should not worry about the last column of the table. We will refer back to this column while studying nomenclature of organic compounds in the next section.

The compounds which are listed in the first category in Table 1.4 are the compounds which contain only carbon and hydrogen. These compounds are also called **hydrocarbons**. The hydrocarbons can be classified as **aliphatic**, **alicyclic** or **aromatic**. In the *aliphatic hydrocarbons*, the carbon atoms are linked to each other to form chains (straight or branched). The aliphatic hydrocarbons can be further classified as *saturated* or *unsaturated*. The saturated hydrocarbons contain the carbon and hydrogen atoms linked to each other by single bonds and are called **alkanes**. The unsaturated hydrocarbons are of two types: the one containing double bond as the functional group are named as **alkenes**; the other containing a triple bond as the functional group are known as **alkynes**.

In the *alicyclic hydrocarbons*, the carbon atoms are arranged in rings to yield cyclic structures. These compounds are also known as **cycloalkanes**.

The *aromatic hydrocarbons* include benzene and those compounds which resemble benzene in their properties.

In fact, the hydrocarbons provide a backbone to which various functional groups may be attached to yield an enormous variety of organic compounds.

Let us now study about the structural features of some classes of aliphatic compounds. The compounds in which the carbon and oxygen atoms are linked by a single bond can be classified as **alcohols** or **ethers**, depending upon the number of alkyl groups attached to oxygen. In alcohols, oxygen is linked to only **one** alkyl group and one hydrogen; but in ethers, oxygen has **two** alkyl groups attached to it. The compounds containing carbon and oxygen linked by a double bond (i.e.,  $>\text{C}=\text{O}$ ), which is called **carbonyl group**, can be classified as **aldehydes** or **ketones**, depending on whether the number of alkyl groups attached to carbonyl carbon is **one** or **two**, respectively. If instead of an alkyl group, one hydroxyl (-OH) group is attached to the carbonyl group, a class of compounds known as **carboxylic acids**

$\begin{array}{c} \text{O} \\ \parallel \\ (\text{R}-\text{C}-\text{OH}) \end{array}$  is obtained. A number of carboxylic acid derivatives are obtained by

replacing the hydroxyl group by halogens,  $-\text{NH}_2$ ,  $-\text{O}-\begin{array}{c} \text{O} \\ \parallel \\ \text{C} \end{array}-\text{R}$  or  $-\text{OR}$  groups.

Accordingly, these compounds are called **acid halides**  $(\text{R}-\begin{array}{c} \text{O} \\ \parallel \\ \text{C} \end{array}-\text{X})$ , **amides**  $(\text{R}-\begin{array}{c} \text{O} \\ \parallel \\ \text{C} \end{array}-\text{NH}_2)$ , **anhydrides**  $(\text{R}-\begin{array}{c} \text{O} \\ \parallel \\ \text{C} \end{array}-\text{O}-\begin{array}{c} \text{O} \\ \parallel \\ \text{C} \end{array}-\text{R}')$  and **esters**  $(\text{R}-\begin{array}{c} \text{O} \\ \parallel \\ \text{C} \end{array}-\text{OR}')$ . They are also called functional derivatives of carboxylic acids, as they are obtained by the changes in the functional group.

In a similar manner, compounds having carbon-nitrogen single bond are called **amines**. The amines can be of three types: **primary**, **secondary** and **tertiary amines** depending upon whether the number of alkyl groups attached to nitrogen is **one**,

The **alkyl** groups, generally represented by R, are derived from **alkanes** by removing one hydrogen. The simplest alkyl group is methyl group (CH<sub>3</sub>-) which is derived from the alkane, methane (CH<sub>4</sub>). Common alkyl groups are listed in Table 1.7. Similarly, **aryl** groups denoted by Ar, are obtained from benzene and its derivatives by removing one hydrogen. The simplest aryl group is **phenyl group** (C<sub>6</sub>H<sub>5</sub>-

or ) and is abbreviated

as Ph. In general, aryl halide (Ar-X) can refer to any of the following:

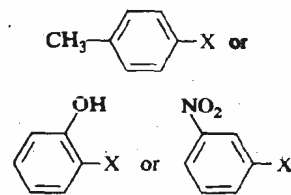

two or three. The carbon-nitrogen double bond is characteristic of the class of compounds known as **imines** while compounds having carbon-nitrogen triple bond are called **nitriles**. Then we have **alkyl halides** which have their unique importance in the transformation of functional groups which you will realise when you study their reactions in the following blocks. The sulphur analogs of alcohols and carboxylic acids are known as **thiols** and **sulphonic acids**, respectively.

Parallel to the classes discussed above for aliphatic compounds, we have **aromatic compounds** in which benzene forms the backbone to which various functional groups mentioned above can be attached to yield similar classes of aromatic compounds, like aryl halides, arylamines, phenols, aromatic carbonyl compounds, aromatic acids and their derivatives, etc. As you have seen in Table 1.4, R is generally used to represent an **alkyl group**; the corresponding aromatic compounds are obtained by replacing R by Ar which denotes an aryl group; this is shown in Table 1.4 in case of alcohol and phenol. In the next section, we will study about the nomenclature of these compounds. Before that attempt the following SAQ to check your understanding about the functional groups.

#### SAQ 4

Encircle and name the functional groups present in the following compounds:

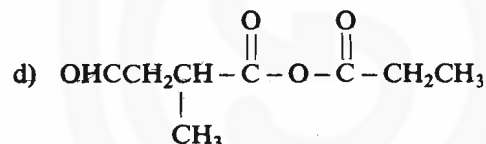
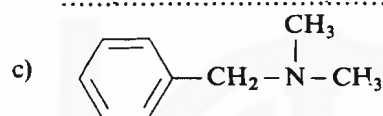
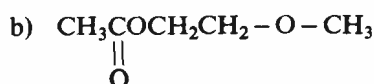
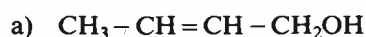

The terms *primary*, *secondary* and *tertiary* as used for classification of branched alkyl substituents are explained under step 8 of nomenclature for branched chain alkanes in the next section

## 1.6 NOMENCLATURE OF ORGANIC COMPOUNDS

The earliest attempts to name organic compounds were based either on their origin or on their properties. For example, citric acid was named so because of its occurrence in *citrus* fruits. The aromatic compounds were called so because of their characteristic odour (Greek: **aroma**, *fragrant smell*). Examples are oil of wintergreen and vanillin (a constituent of vanilla also used as a flavouring agent) which were called aromatic due to their characteristic fragrance. With the advancement and growth in the knowledge of chemistry, the number of known organic compounds has increased rapidly. Also, with the increase in the number of carbon atoms, the number of possible isomers for hydrocarbons (without any functional group) becomes very large (see Table 1.5).

Table 1.5 : Possible Number of Isomers for Hydrocarbons

Number of carbon atoms in the hydrocarbon	4	5	6	7	8	9	10	12	15	20
Number of possible isomers	2	3	5	9	18	35	75	355	4,347	366,319

Isomers are the compounds that have identical molecular formulas but differ in the ways in which the atoms are bonded to each other. For example, four carbons in a hydrocarbon having molecular formula  $\text{C}_4\text{H}_{10}$  can be arranged in the two different ways:

Straight chain  
 $\text{H}_3\text{C} - \text{CH}_2 - \text{CH}_2 - \text{CH}_3$   
 common name : normal butane or *n*-butane

Branched chain  
 $\begin{array}{c} \text{CH}_3 \\ | \\ \text{H}_3\text{C} - \text{CH} - \text{CH}_3 \end{array}$   
 common name : isobutane

Thus, *n*-butane and isobutane are isomers.

Having learnt about the variety of functional groups, you can imagine that the nature and position of functional groups present can raise these numbers many fold. Under such a situation, it is next to impossible to learn the names randomly assigned to the compounds, especially when there is no correlation of the name to the structure of the compound. This necessitated the need to have a **systematic nomenclature** for which the International Committee of Chemists met at Geneva in 1892. The work was carried on by the **International Union of Chemists (I.U.C.)** which gave its report in 1931, known as the I.U.C. system of nomenclature. As the nomenclature is always undergoing modifications and revisions, the latest rules which are widely accepted were recommended by the Commission on Nomenclature of Organic Chemistry of the **International Union of Pure and Applied Chemistry (I.U.P.A.C.)**. We will now study this system in detail.

Since the nomenclature of other classes of compounds is based on the nomenclature of alkanes, let us start the study of nomenclature with the alkanes. **Alkanes** are represented by the general formula  $C_nH_{2n+2}$  where  $n$  can be 1, 2, 3, 4... etc. The first four alkanes retain their original or nonsystematic names. The names of alkanes higher than these start with a prefix (Greek or Latin words) which indicates the number of carbon atoms in the chain and end with suffix **-ane**. The IUPAC names for various alkanes having different chain lengths are given in Table 1.6. The unbranched alkanes have their common names as normal alkanes or  $n$ -alkanes.

Table 1.6 : IUPAC Names of straight chain alkanes having general formula  $C_nH_{2n+2}$

n	Formula	Name	n	Formula	Name
1	CH <sub>4</sub>	methane	11	CH <sub>3</sub> (CH <sub>2</sub> ) <sub>9</sub> CH <sub>3</sub>	undecane
2	CH <sub>3</sub> CH <sub>3</sub>	ethane	12	CH <sub>3</sub> (CH <sub>2</sub> ) <sub>10</sub> CH <sub>3</sub>	dodecane
3	CH <sub>3</sub> CH <sub>2</sub> CH <sub>3</sub>	propane	13	CH <sub>3</sub> (CH <sub>2</sub> ) <sub>11</sub> CH <sub>3</sub>	tridecane
4	CH <sub>3</sub> (CH <sub>2</sub> ) <sub>2</sub> CH <sub>3</sub>	butane	14	CH <sub>3</sub> (CH <sub>2</sub> ) <sub>12</sub> CH <sub>3</sub>	tetradecane
5	CH <sub>3</sub> (CH <sub>2</sub> ) <sub>3</sub> CH <sub>3</sub>	pentane	15	CH <sub>3</sub> (CH <sub>2</sub> ) <sub>13</sub> CH <sub>3</sub>	pentadecane
6	CH <sub>3</sub> (CH <sub>2</sub> ) <sub>4</sub> CH <sub>3</sub>	hexane	20	CH <sub>3</sub> (CH <sub>2</sub> ) <sub>18</sub> CH <sub>3</sub>	*icosane
7	CH <sub>3</sub> (CH <sub>2</sub> ) <sub>5</sub> CH <sub>3</sub>	heptane	30	CH <sub>3</sub> (CH <sub>2</sub> ) <sub>28</sub> CH <sub>3</sub>	triacontane
8	CH <sub>3</sub> (CH <sub>2</sub> ) <sub>6</sub> CH <sub>3</sub>	octane	40	CH <sub>3</sub> (CH <sub>2</sub> ) <sub>38</sub> CH <sub>3</sub>	tetracontane
9	CH <sub>3</sub> (CH <sub>2</sub> ) <sub>7</sub> CH <sub>3</sub>	nonane	50	CH <sub>3</sub> (CH <sub>2</sub> ) <sub>48</sub> CH <sub>3</sub>	pentacontane
10	CH <sub>3</sub> (CH <sub>2</sub> ) <sub>8</sub> CH <sub>3</sub>	decane	100	CH <sub>3</sub> (CH <sub>2</sub> ) <sub>98</sub> CH <sub>3</sub>	hectane

Compounds that differ from each other in their molecular formulas by the unit  $-CH_2-$  are called members of a **homologous series**. Thus, the compounds listed in Table 1.6 belong to a homologous series.

\*Prior to 1979 version of IUPAC rules, it was spelled as eicosane.

The branched chain alkanes are named by using the following steps:

1. The longest continuous chain of carbon atoms is taken as the parent hydrocarbon. For example, in the compound shown below, the parent hydrocarbon is heptane and not the hexane.

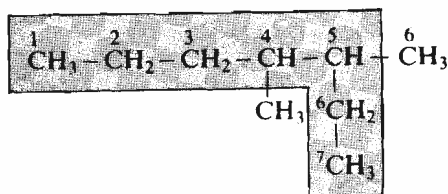

2. Identify the substituent alkyl groups attached to the parent chain. Some

common alkyl groups are listed in Table 1.7. You can locate that both the substituents in the example cited above are methyl groups.

Table 1.7 : Common Alkyl groups

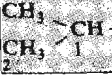
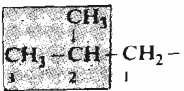
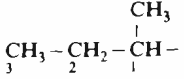
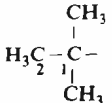
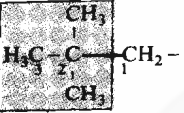
Alkyl group	Common name	IUPAC name
CH <sub>3</sub>	methyl	methyl
CH <sub>3</sub> CH <sub>2</sub> -	ethyl	ethyl
CH <sub>3</sub> CH <sub>2</sub> CH <sub>2</sub> -	<i>n</i> -propyl	propyl
	<b>iso</b> propyl	1-methylethyl
CH <sub>3</sub> CH <sub>2</sub> CH <sub>2</sub> CH <sub>2</sub> -	<i>n</i> -butyl	butyl
	<b>iso</b> butyl	2-methylpropyl
	<i>sec</i> -butyl	1-methylpropyl
	<i>tert</i> -butyl	1, 1-dimethylethyl
	<b>neo</b> pentyl	2, 2-dimethylpropyl

### Bonding, Functional Group Classification and Nomenclature

The IUPAC system of nomenclature has retained some of the older names for branched alkyl groups such as isopropyl, isobutyl, *sec*-butyl, *tert*-butyl and neopentyl.

Note that the numbering of carbon atoms is from the point of attachment of the group to the parent chain.

3. The parent carbon chain is then numbered in such a way that the substituents get the lowest possible numbers. The carbon atoms in the above compound can be numbered as,

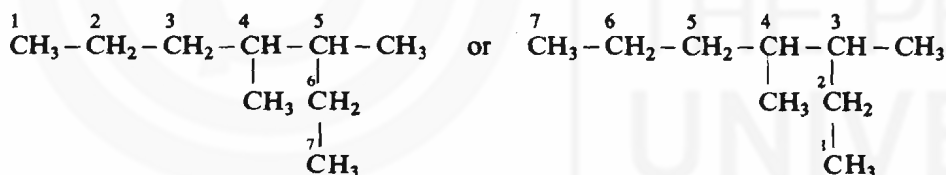

Can you guess which of the two numbering systems is correct? The first possibility locates the methyl groups at carbons 4 and 5 and the second way at carbons 3 and 4. Certainly, the second way of numbering the carbon chain is correct.

4. Prefixes *di*, *tri*, *tetra*, *penta* etc., are used when the substituents occur more than once. Since in the above compound the methyl substituent is occurring *twice*, the name is prefixed with *di* for the above compound.
5. The name of the compound is written by writing the location and name of the substituents followed by the name of the parent alkane. Thus, the above compound can be named as 3,4-dimethylheptane. Note that a comma is used to separate the two numbers and the numbers are separated from names of groups by a hyphen. Also note that there is no blank space between the name of the last substituent and the parent alkane.
6. When more than one type of alkyl groups are present, then they are cited in the name in the alphabetical order regardless of their location in the principal chain. The numerical prefixes *di*, *tri*, *tetra*, etc. and hyphenated prefixes such as *sec*-, *tert*- are not considered in determining the alphabetical order but prefixes *iso*, *neo*, *cyclo* are considered for alphabetising. To understand it, let us consider the examples given below:







to the carbon atom to which the halogen is attached. For example, some halogen compounds are named below:

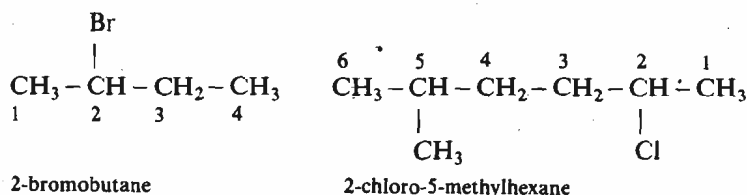

When more than one type of halogen atoms are present, their names are arranged in alphabetical order as shown in the next example,

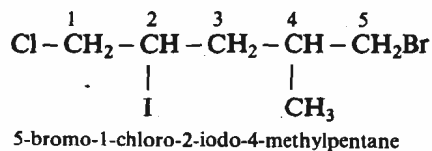

**Alcohols:** Alcohols are the compounds having hydroxyl (-OH) group attached to the alkyl chain. The common names of the alcohols are written by specifying the alkyl group followed by the word alcohol, e.g.,



In the IUPAC nomenclature, suffix *ol* is used instead of final *e* of the parent hydrocarbon. The position of the hydroxyl group is given by assigning the lowest possible number to the carbon atom carrying it. Some examples are:

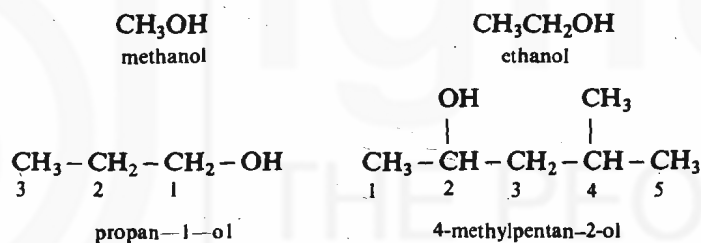

**Ethers:** The common names for ethers are derived by naming the two alkyl groups in alphabetical order followed by the word ether. This is illustrated in the examples given below:



In the IUPAC system, ethers are named as **alkoxyalkanes**. The larger of the two alkyl groups is chosen as the hydrocarbon chain. For example, the compound,



is named as 1-methoxyethane and not as ethoxymethane. Similarly, the compound,

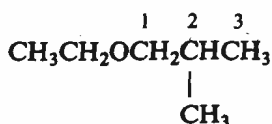

has the name 1-ethoxy-2-methylpropane.

**Aldehydes:** Lower members of this class are commonly named after the acids that they form on oxidation. For example, HCHO, formaldehyde is named so because it forms formic acid (HCOOH) on oxidation.

In the IUPAC system of nomenclature, they are named as **alkanals**. The simplest aldehyde is methanal. Since the aldehyde group (-CHO) is always at the end of the chain, it is always numbered as C-1 in the chain, but this number is not specified in the name, i.e. the compound



by replacing *e* ending of the alkane by *oic acid*. As for aldehydes, the carboxyl carbon is numbered 1. However, in case of the dicarboxylic acids, the final *e* of the hydrocarbon is not dropped.

**Acyl halides:** Acyl halides are commonly named by placing the names of the halide after the name of the acyl group. The acyl group is obtained from the carboxylic

acid by removal of its hydroxyl portion, i.e.  $R-\overset{\text{O}}{\parallel}{C}-OH$  leads to  $R-\overset{\text{O}}{\parallel}{C}-$  acyl group. The acyl group is named by using *yl* as the ending instead of ending *ic* in the carboxylic acid. Some such examples are:

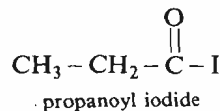
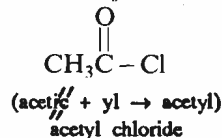

IUPAC names for acyl groups use the ending *oyl* instead of ending *e* in the name of the corresponding hydrocarbon. The acetyl chloride has the IUPAC name

ethanoyl chloride. Another example is  $\begin{array}{c} \text{CH}_3 \\ \diagdown \\ \text{CHC}-\text{Cl} \\ \diagup \\ \text{CH}_3 \end{array}$  which is named as 2-methylpropanoyl chloride.

**Acid amides:** The common names for acid amides are derived by replacing the suffix *ic* or *oic* of the carboxylic acid by the suffix *amide* as shown below:

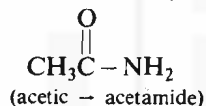

The IUPAC name for an amide is derived by appending the suffix *amide* to the parent hydrocarbon with the final *e* dropped. Thus, acetamide has the IUPAC name **ethanamide**. Having done this, can you give common and IUPAC names for

$\begin{array}{c} \text{O} \\ \parallel \\ \text{HC}-\text{NH}_2 \end{array}$ ? These are formamide and methanamide, respectively.

**Acid anhydrides:** A symmetrical anhydride is named as anhydride of the parent

acid. Thus,  $\text{CH}_3-\overset{\text{O}}{\parallel}{C}-\text{O}-\overset{\text{O}}{\parallel}{C}-\text{CH}_3$ , the anhydride which is obtained from ethanoic acid (common name: acetic acid) is commonly known as acetic anhydride. The IUPAC name for this anhydride is ethanoic anhydride.

For mixed anhydrides, both the parent carboxylic acids are cited in alphabetical order, followed by the word anhydride, as illustrated below:

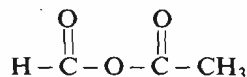

ethanoic methanoic anhydride  
(common name : acetic formic anhydride)

**Esters:** As the esters contain alkyl and alkanoyl (acyl) groups, they are named as **alkyl alkanoates**. The alkyl group is cited first, followed by the name of the alkanoyl (acyl) portion which is named by replacing the *ic* ending of the carboxylic acid by the suffix *ate*.

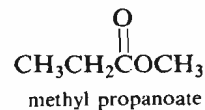
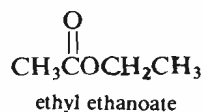
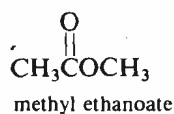

**Amines:** There are two systems of naming amines. One method names them as **alkylamines** and the other calls them as **alkanamines**. The alkanamine naming system was introduced by **Chemical Abstracts** and is easier to use as compared to the earlier IUPAC system of alkylamine names. The latest revision of IUPAC rules accepts both systems and examples below are named in both the ways.

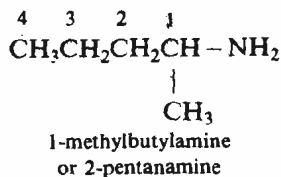
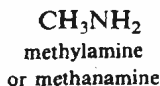

(Note that the numbering starts at the carbon and not at the nitrogen of the amine part).

Primary diamines are named by using the suffix **diamine** after the name of the hydrocarbon.

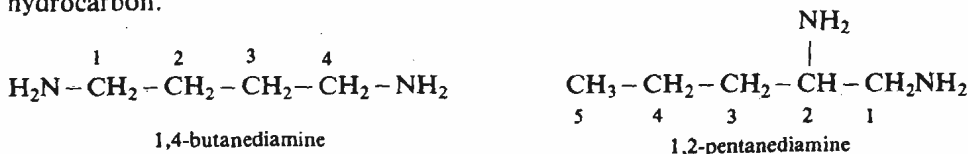

For the secondary and the tertiary amines, the longest alkyl group present is considered as the parent chain. The remaining alkyl groups are named as **substituents** attached to the nitrogen and a prefix *N*- is used with the name of the alkyl group.

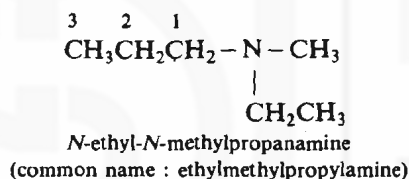
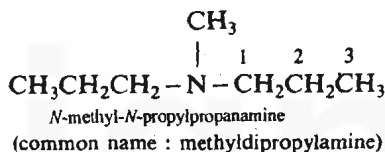
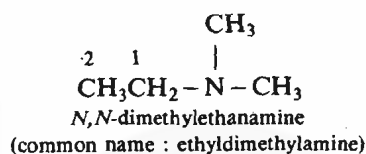
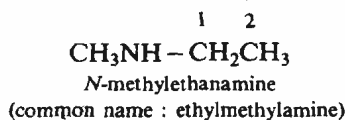
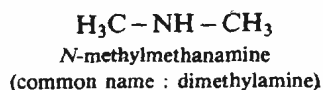

When used as a substituent, the  $-\text{NH}_2$  group is named as **amino** and is prefixed with a number indicating the carbon atom to which it is attached.



**Nitro compounds:** The nitro compounds are named as nitroderivatives of the corresponding hydrocarbons.

Examples being,

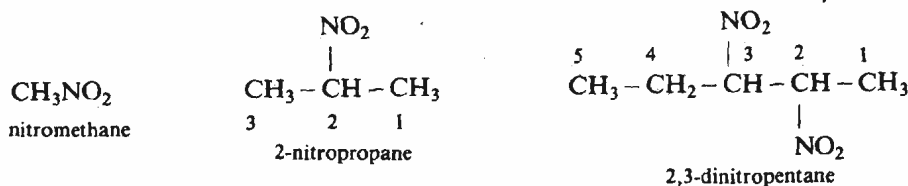

**Nitriles:** Nitriles are named in the IUPAC system by using the suffix **-nitrile** to the name of the hydrocarbon corresponding to the longest carbon chain. Note that here the carbon of the nitrile group is included in the numbering of carbon chain and is numbered as position 1. Some examples are given below:

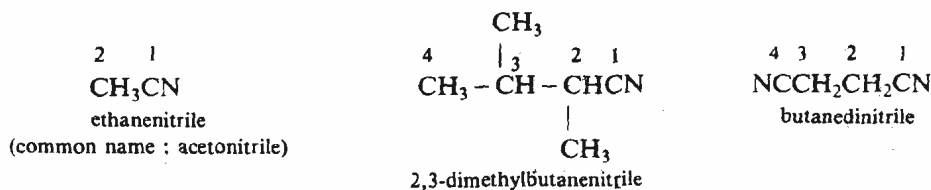

When named as a substituent, the  $-\text{CN}$  group is called a **cyano** group. For example, the compound

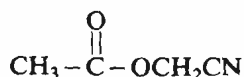

is named as cyanomethyl ethanoate.

**Thiols** : In naming thiols, an ending *thiol* is used as a suffix to the name of the corresponding hydrocarbon; for example,

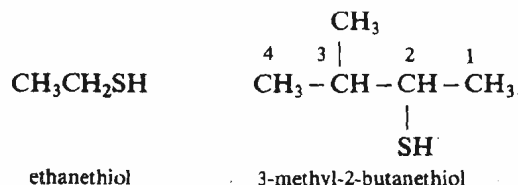

**Sulphonic acids**: The names of sulphonic acids use the suffix *sulphonic acid* with the name of the corresponding hydrocarbon.

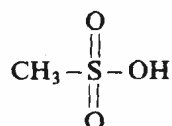

methanesulphonic acid

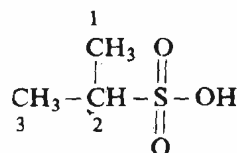

2-propanesulphonic acid

The order of priority for various functional groups is decided by considering the following points :

- Functional groups that have an IUPAC **suffix** and terminate a carbon chain, have highest priority, e.g., carboxylic acids and their derivatives.

- Next are the groups that have a suffix and can be located at any position in the molecule, e.g., hydroxy and amino groups.

- Groups having no suffix and which are named as substituents, are given the lowest priority. Example being the halogens.

Till now, you have studied about the nomenclature of monofunctional compounds, i.e. the compounds which contain only one functional group. In polyfunctional compounds where more than one functional groups are present, one group is identified as the principal functional group and this principal functional group is used as a suffix in the name of the compound. The priorities for selection of principal functional group are given below in the order of decreasing precedence. The order is carboxylic acid, sulphonic acid, ester, acid anhydride, acyl halide, amide, nitrile, aldehyde, ketone, alcohol, thiol, amine, imine, alkyne, alkene, ethers, halides, nitro.

Let us study the examples given below which illustrate the nomenclature of polyfunctional compounds.

#### Example 1

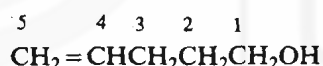

Here, the functional groups present are a hydroxyl group ( $-\text{OH}$ ) and a double bond. As per the order given above, the hydroxyl group is the principal functional group and hence the compound should be named as an alcohol (an not as an alkene). Hence, its name is pent-4-ene-1-ol.

#### Example 2

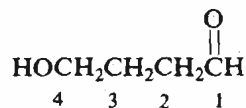

Now, in this case the carbonyl group or more specifically the aldehyde functional group ( $-\text{CHO}$ ) is to be given priority over the hydroxyl group. Hence, this compound is named as 4-hydroxybutanal.

#### Example 3

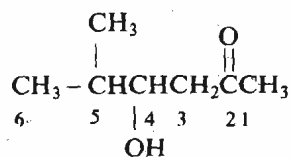

The principal functional group is the keto group. Hence, as shown in the structure, the numbering of the carbon-chain will be done so as to give this function the lowest number. Thus, the name of this compound will be 4-hydroxy-5-methyl-2-hexanone.

Let us next study the nomenclature of aromatic compounds. The aromatic compounds can have any of the following types of basic skeletons :

- a) **Compounds containing one aromatic ring.** This class includes benzene and its derivatives. The derivatives of benzene include the compounds which can have any of the functional groups discussed before attached to the benzene ring.
- b) **Compounds containing two aromatic rings.** Examples being naphthalene and biphenyl.

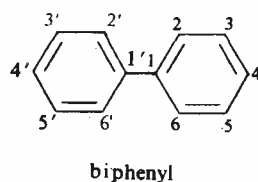
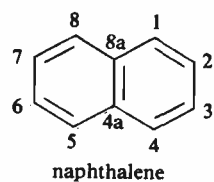
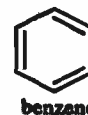

- c) **Compounds having more than two aromatic rings.** Examples are,

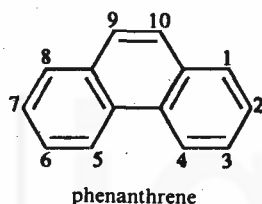
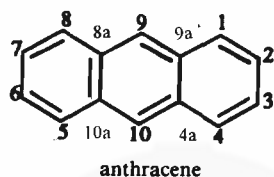

- d) **Heterocyclic compounds:** Aromatic compounds containing heteroatoms such as O, N or S in the aromatic ring are called heterocyclic compounds. Some heterocyclic compounds are shown below:

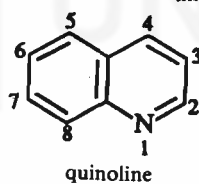
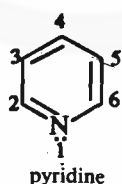
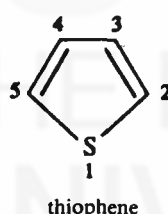
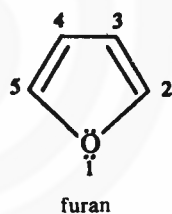
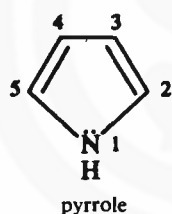

At this stage we will study in detail the nomenclature of benzene and its derivatives only. Although the carbon skeletons for the type of compounds shown in the categories (b), (c) and (d) are numbered here, their nomenclature will be dealt at appropriate places in later units of this course.

- a) **Benzene and its derivatives:** A number of monosubstituted benzene derivatives are known by their special names. These names are in common use for long and hence are approved by IUPAC. Some examples of these compounds are given below along with their common and IUPAC names (in brackets).

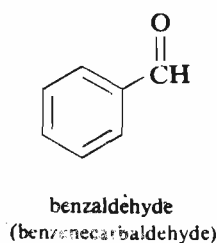
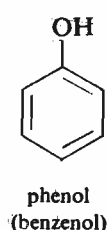
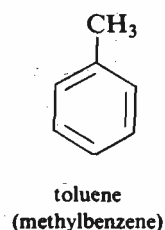

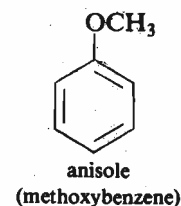
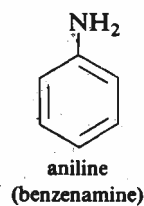
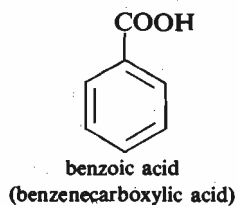

For disubstituted benzene derivatives, the following three arrangements of the substituents are possible.

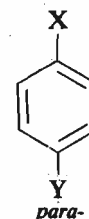
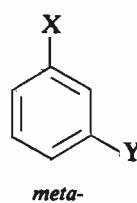
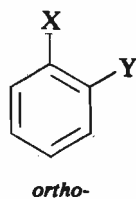

These arrangements are named using the Greek prefixes *ortho-*, *meta-* and *para-* which are abbreviated as *o-*, *m-* and *p-*. The substituents are then named in the alphabetical order. This is illustrated in the examples below.

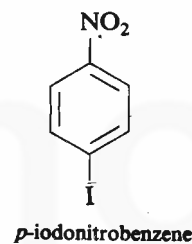

Dimethyl derivatives of benzene are known as **xylene**s. The three xylenes are,

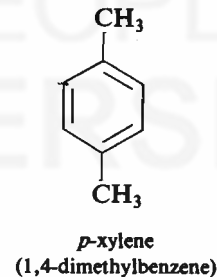
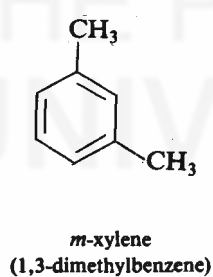
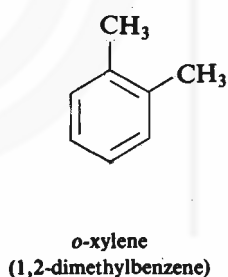

When one substituent is such that it corresponds to the monosubstituted benzene that has a special name, then this substituent is called the principal functionality and the compound is named as a derivative of that parent functionality. For example,

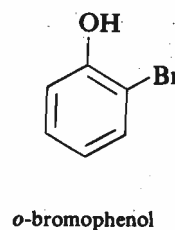
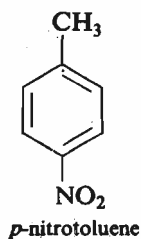

The polysubstituted benzenes are named by identifying the principal functions and then numbering is done such as to keep the principal function as number 1. The other substituents are then given the lowest possible numbers. This is illustrated in the following examples.



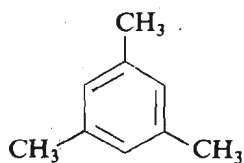

1,3,5-trimethylbenzene  
(common name : mesitylene)

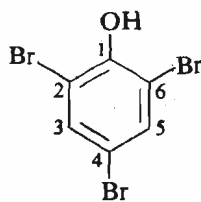

2,4,6-tribromophenol

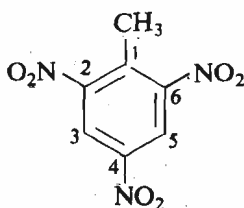

2,4,6-trinitrotoluene (TNT)

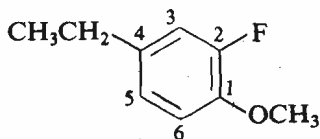

4-ethyl-2-fluoroanisole

Having studied the nomenclature in detail, attempt the following SAQs to check your understanding about it.

**SAQ 5**

Name the following compounds according to IUPAC system of nomenclature.

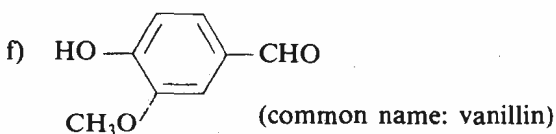
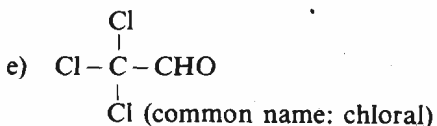
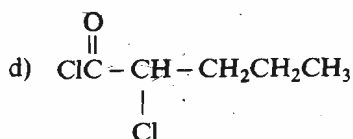
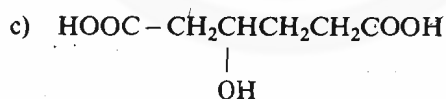
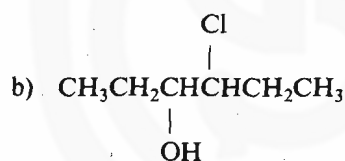
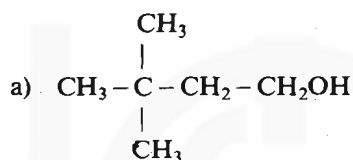

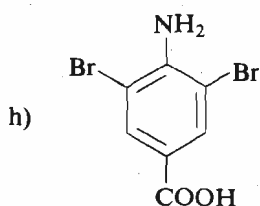
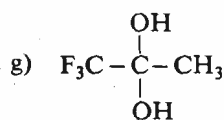
**SAQ 6**

Given below are the names of some compounds. Write their structures.

a) 3-ethyl-3-pentanol

.....

b) 3-methyl-2-buten-1-ol

.....

c) 2-bromo-4-nitrotoluene

.....

d) 5-hexyn-2-one

.....

e) benzoic anhydride

.....

f) ethyl formate

.....

**1.7 SUMMARY**

In this unit you have studied about the basic features of the covalent bond which is the bond occurring in all the compounds of carbon and is responsible for the formation of organic compounds. Then you have learnt how to write structures for these organic compounds. The formation of simple organic compounds is explained by using the concept of hybridisation. As these organic compounds are conveniently studied by grouping the similar compounds together in a class, classification of organic compounds has been dealt with in detail. The nomenclature of various classes of the organic compounds is also discussed using simple examples.

**1.8 TERMINAL QUESTIONS**

1. Expand the following line structures.

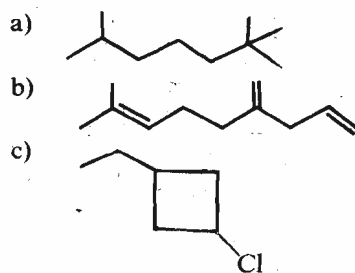

2. The structural formula for allene is shown below. Illustrate the formation of bonds in allene by showing the overlap of the orbitals using a diagram.

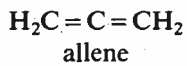

3. Many compounds isolated from natural sources often show more than one functional group. Given below are some such compounds. Identify the functional groups present in these compounds.

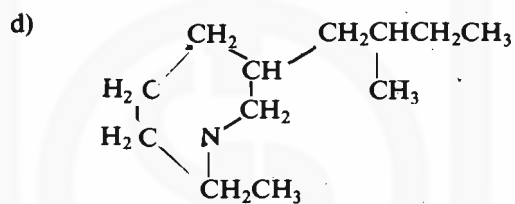
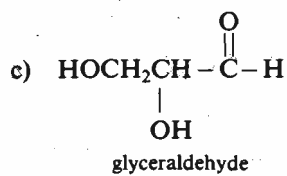
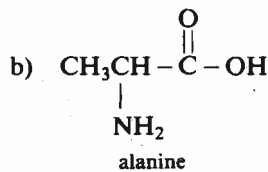
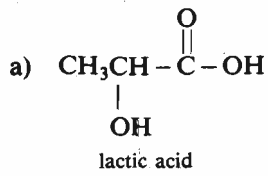

a substance produced by a beetle to help it float on water.

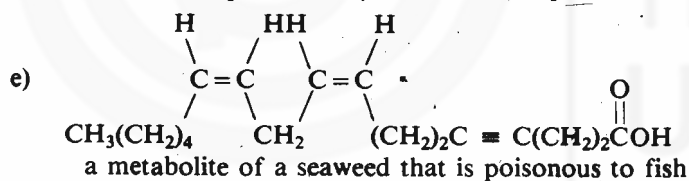

4. For compounds having molecular formula,  $\text{C}_3\text{H}_5\text{Cl}_3$ , write structural formulas for all possible isomers and name them.
5. Write the structural formulas and IUPAC names for the following compounds:
- butanoic acid
  - and its
    - acid chloride
    - acid anhydride
    - acid amide
    - methyl ester

## 1.9 ANSWERS

### Self Assessment Questions

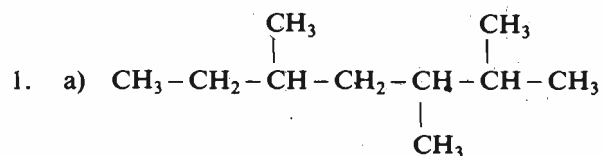



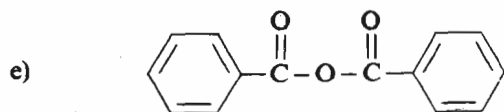
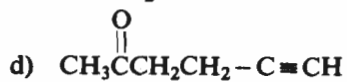
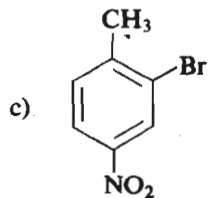
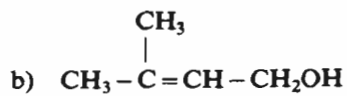

Terminal Questions

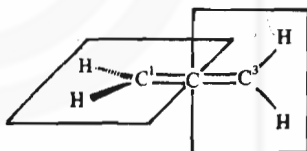
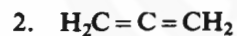
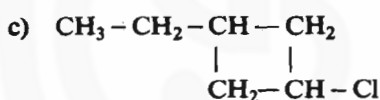
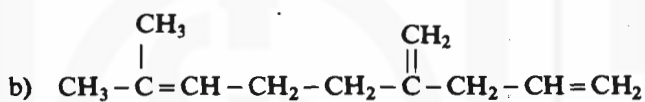
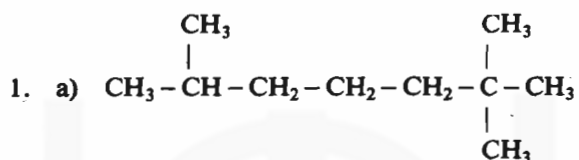

(a) Planes defined by H(C-1)H and H(C-3)H are mutually perpendicular

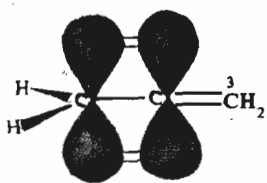

equivalent to

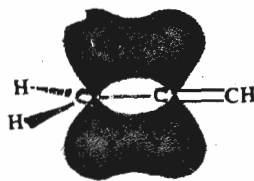

(b) The p orbital of C-1 and one of those of C-2 can overlap to form a  $\pi$  bond

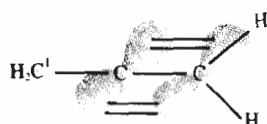

equivalent to

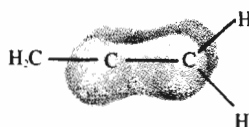

(c) The p orbital of C-3 and one of those of C-2 can overlap to form a second  $\pi$  bond perpendicular to the one in (b)

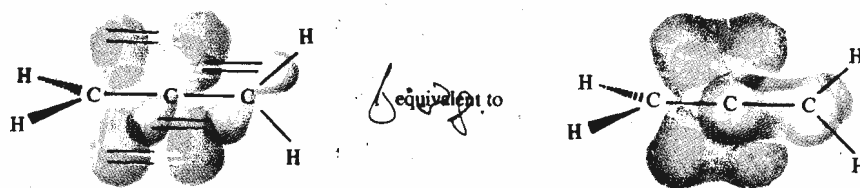

(d) Allene has a linear chain and two mutually perpendicular  $\pi$  bonds

3. a)  $-\text{OH}$  and  $-\text{COOH}$  groups  
 b)  $-\text{NH}_2$  and  $-\text{COOH}$  groups  
 c) Two  $-\text{OH}$  groups (one primary and one secondary) and one  $-\text{CHO}$  group.  
 d)  $-\text{N} \leq$  group.  
 e) Two double bonds, one triple bond and a  $-\text{COOH}$  group.

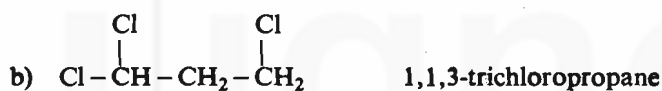

5.      **Formula**      **IUPAC name**
- a)  $\text{CH}_3\text{CH}_2\text{CH}_2\text{COOH}$       butanoic acid
- b)  $\text{CH}_3\text{CH}_2\text{CH}_2\text{COCl}$       butanoyl chloride
- c)  $\text{CH}_3\text{CH}_2\text{CH}_2\overset{\text{O}}{\parallel}\text{C} - \text{O} - \overset{\text{O}}{\parallel}\text{CCH}_2\text{CH}_2\text{CH}_3$       butanoic anhydride
- d)  $\text{CH}_3\text{CH}_2\text{CH}_2\overset{\text{O}}{\parallel}\text{CNH}_2$       butanamide
- e)  $\text{CH}_3\text{CH}_2\text{CH}_2\overset{\text{O}}{\parallel}\text{C} - \text{OCH}_3$       methyl butanoate

---

# UNIT 2 STEREOCHEMISTRY – I

---

## Structure

- 2.1 Introduction
  - Objectives
- 2.2 Isomerism
- 2.3 Geometrical Isomerism
- 2.4 Characterisation of Geometrical Isomers
- 2.5 Optical Isomerism
  - Plane Polarised Light and Optical Activity
  - Origin of Optical Activity
  - Chirality
- 2.6 Chirality and Elements of Symmetry
- 2.7 Summary
- 2.8 Terminal Questions
- 2.9 Answers

---

## 2.1 INTRODUCTION

---

Although we are habituated to writing the structures of organic molecules in two dimensions but actually they have three-dimensional structures. The term **Stereochemistry** is coined from the Greek word **stereos** meaning “solid” and it deals with the chemistry in three dimensions. In addition to the study of the geometry of molecules which is referred to as **stereoisomerism**, stereochemistry is concerned also with the effect of molecular geometry (i.e., the three-dimensional structure of molecules) on chemical reactions and chemical equilibria. While these aspects will be dealt with in detail at appropriate places in this course and in the Organic Reaction Mechanism course, in this unit, we will confine our discussion mainly to stereoisomerism. We will begin with the concept of isomerism in general and then study geometrical and optical isomerism in detail.

While studying this Unit and Unit 3 which also deals with stereochemistry, you are advised to take help of the models. You can make models using the students set of models provided to you. Before using the models, go through the guidelines for using the models given in the study guide. For better understanding of the material, you should yourself do the various activities given in the margin.

### Objectives

After studying this unit, you should be able to:

- list and define various types of isomerism,
- write geometrical isomers and designate them as *cis-* or *trans-* and *E* or *Z* isomers,
- predict whether a compound will show optical activity or not just by examining its structure,
- write the enantiomers for a given compound,
- differentiate between enantiomers and diastereoisomers,
- locate chiral centres in a molecule, and
- identify the elements of symmetry present in a molecule.

---

## 2.2 ISOMERISM

---

The phenomenon of existence of two or more compounds having the same molecular formula is known as **isomerism** and these compounds are individually referred to as **isomers**. Isomerism can be of various types. The different types of isomerism are represented below in a flow chart.

*Isomers* have same molecular formula but they differ from each other in their physical and chemical properties.

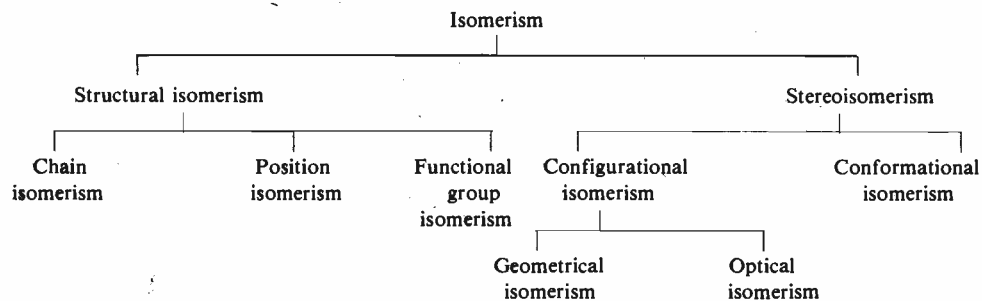

Let us now study each type of isomerism in detail.

Isomerism, which is one of the important characteristics of organic compounds, arises because of the number and variety of ways in which carbon atoms, which form the back-bone of organic molecules, can link with each other. On this is superimposed the position and linking of various heteroatoms like O, N, S, halogens etc., giving rise to a very large number of isomers. The number increases with the number and variety of atoms present in a molecule. So a study of the structure of the molecule is implicit and molecular formula alone is not enough.

The two isomeric butanes are distinct entities having different boiling points.

1. **Structural Isomerism** arises due to differences in the structures of the molecules. These structural differences can be further classified into three types; accordingly, the three types of structural isomerism are as given below:

a) **Chain isomerism** is exhibited by the compounds which differ from each other in the way the carbon atoms form the basic skeleton. You have already studied such type of compounds in Unit 1, Sec. 1.6 where we considered that four carbon atoms can be linked to each other in two different ways to form either a straight chain of carbon atoms or a branched chain, as shown below :



These straight chain and branched chain carbon skeletons correspond to two different hydrocarbons having the molecular formula  $\text{C}_4\text{H}_{10}$ . These are commonly called *n*-butane and isobutane and are shown below.

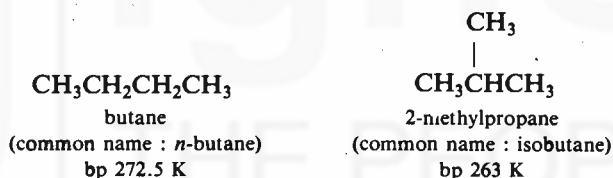

Thus, butane and 2-methylpropane exhibit chain isomerism. Similarly, five carbon atoms can have any of the following arrangements:

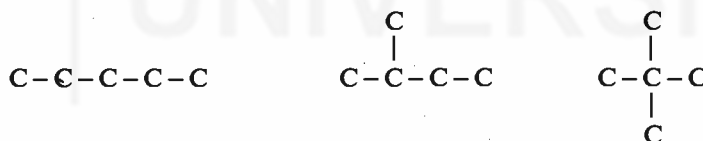

Corresponding to these arrangements, the isomeric hydrocarbons are shown below.

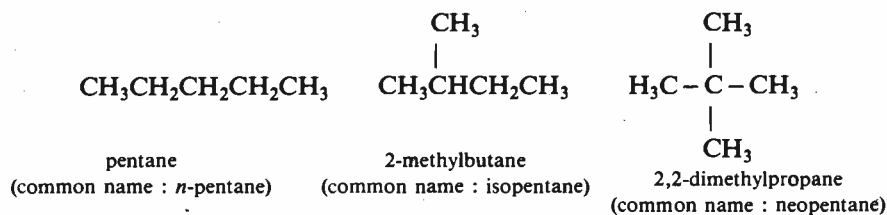

b) **Position Isomerism** is different from chain isomerism in the sense that here the isomers have the same carbon skeleton but they differ from each other in the *position* of the substituent groups. For example, in a straight chain hydrocarbon having three carbon atoms, a substituent can be either at C-1 position or at C-2 position, i.e. if the substituent is a hydroxyl group, then the two position isomers are:



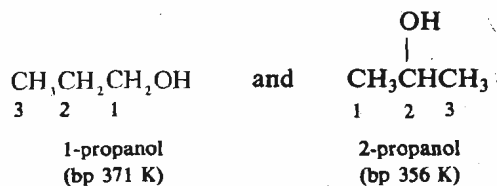

- c) **Functional Group Isomerism** is exhibited by compounds having the same molecular formula but different functional groups. For example, the molecular formula  $\text{C}_3\text{H}_6\text{O}$  corresponds to both propanone and propanal;



Here, the functional groups are the keto and the aldehyde groups, respectively. Such isomers thus belong to different classes.

2. **Stereoisomerism** is exhibited by compounds which have the **same** Lewis structure (or structural formula) but differ from each other in the spatial arrangement of the atoms or groups in their molecules. Such isomers are called **stereoisomers**. Stereoisomerism can be further classified into two types as given below:

- a) **Configurational Isomerism**: The absolute configuration of a compound can be defined as the actual orientation of the groups in space. This type of isomerism is exhibited by those stereoisomers which cannot be converted to each other without breaking of bonds. It can be further classified into geometrical isomerism and optical isomerism.
- i) **Geometrical isomerism** is caused by different arrangements of the groups around a rigid framework. This rigid framework can be a double bond or a cyclic structure around which the various groups are attached. Later, you will study that due to this rigid framework, interconversion of such isomers is not easily possible.
- ii) **Optical isomerism** arises due to molecular asymmetry and as the name indicates, this type of isomerism is manifested by the rotation of the plane of plane-polarised light. In this unit, you will study geometrical and optical isomerisms in detail.
- b) **Conformational Isomerism** arises due to different spatial arrangements of groups in a molecule which are obtained by rotation about single bonds. Each such arrangement is called a **conformation**. You will study more about conformations in Unit 3 of this block.

At this stage you check your understanding about various kinds of isomerism by answering the following SAQ.

### SAQ 1

Write all possible structural isomers of  $\text{C}_3\text{H}_6\text{O}$ .

.....

.....

.....

## 2.3 GEOMETRICAL ISOMERISM

It was pointed out in the last section that geometrical isomerism is possible when groups are attached to a rigid framework like a double bond. You also studied earlier in Unit 1, Sec. 1.4, that a double bond is constituted by a *sigma* and a *pi* bond. Since the  $\pi$  bond is formed by the lateral overlap of *p* orbitals, rotation about the double bond is not possible without breaking it. You can verify this by making a model of ethene. Here you should be aware of the fact that the model of

## Activity

Make a model of ethene,

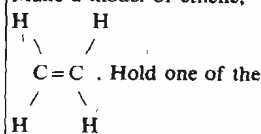

carbon atomic centres and try to rotate the double bond: You will find that it is not possible to rotate one carbon atom with respect to the other without breaking one of the bonds.

ethene does not show the complete picture of the  $\pi$  bond, as was illustrated in Fig. 1.2.

Let us now study how geometrical isomerism arises when such a rigid framework is present. For this, consider the case of 2-butene. We can write its structure as shown below.

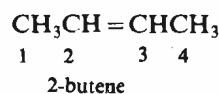

But actually two different compounds corresponding to this structure exist. You can yourself see this by writing the structural formulas for these two compounds. To do this start by writing the C-2 and C-3 carbon atoms of the carbon skeleton as:

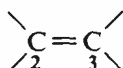

As shown in the structure of 2-butene, a methyl group and a hydrogen atom are linked to C-2 carbon; hence, attach a  $\text{CH}_3$  group and a hydrogen to C-2 carbon as shown below:

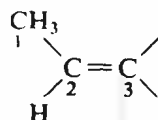

Similarly, a  $-\text{CH}_3$  group and a hydrogen atom are linked to the C-3 carbon atom. When you try to put this second methyl group at C-3 carbon, you have two possibilities:

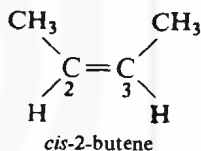

or

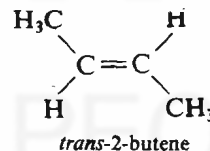

Clearly, in the first case, the two methyl groups are on the same side of the double bond and in the second structure one methyl group is on one side and the other methyl group is on the opposite side of the double bond. These two butenes are differentiated from each other by attaching the prefixes *cis-* (a Latin word meaning *on this side*) and *trans-* (a Latin word meaning *across*) in their names. Hence, these two butenes are named as *cis-2-butene* and *trans-2-butene*, respectively. Thus, *cis-* and *trans-2-butenes* exhibit geometrical isomerism and therefore, they are called geometrical isomers.

In other words, we can say that *cis-trans-* or geometrical isomers are the isomers of

the type  $\text{baC} = \text{Cab}$ . Hence, in the molecules of the type  $\begin{array}{c} \text{a} \quad \text{b} \quad \text{a} \quad \text{b} \\ \diagdown \quad / \quad \diagdown \quad / \\ \text{C} = \text{C} \quad \text{or} \quad \text{C} = \text{C}' \\ / \quad \diagdown \quad / \quad \diagdown \\ \text{a} \quad \text{b} \quad \text{a} \quad \text{d} \end{array}$  where

the carbon atoms forming the double bond carry identical substituents, such an isomerism is not possible.

Let us now see what happens when all the four substituents around the double bond are different. For such a case, the following different arrangements of the groups are possible,

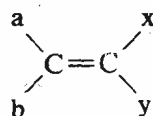

and

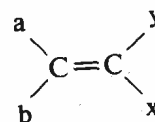

## Activity

Make models of *cis-* and *trans-2-butenes*. Try to interconvert them by taking either of models of *cis-* or *trans-* isomer. To do this, try to rotate the substituents at one end of the double bond, keeping the substituents of the other end fixed. You will realise that by continuously applying the force for rotation of the substituents, you will break one bond of the double bond. So, *cis-* to *trans-* or *trans-* to *cis-* conversion is not possible by rotation about the double bond. Theoretically, the reason for this is that when we try to rotate the substituents around a double bond, the overlap of  $p$  orbitals forming the  $\pi$  bond decreases. The increasing rotation finally leads to no overlap between  $p$  orbitals, or breaking of  $\pi$  bond. Thus, *cis-* and *trans-* isomers are two different compounds which are capable of independent existence.

The question that immediately arises is how to differentiate these two compounds? Can you designate them as *cis*- or *trans*-? The answer is **No** because the *cis*- *trans*-nomenclature does not provide clear guidelines about how to designate these isomers.

To designate such isomers, an unambiguous system of nomenclature, based on the sequence rules developed by **Cahn-Ingold and Prelog**, is used. In this system each of the two groups attached to same carbon atom of the double bond is assigned priority according to the sequence rules. This is done for both the carbon atoms forming the double bond. If the groups of higher priority are on opposite sides of the double bond, then the isomer is said to have *E* configuration. Otherwise, when the groups having higher priority are on the same side of the double bond, then the isomer is known as *Z* isomer. The letters *E* and *Z* are derived from the German words *entgegen* meaning **opposite** and *zusammen* meaning **together**. Thus, we can say that,

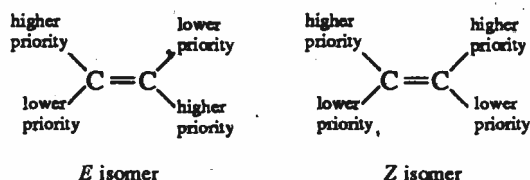

Although the Cahn-Ingold-Prelog sequence rules and the *E-Z* system have been sanctioned by IUPAC, use of *cis*- *trans*-nomenclature in the cases where it can be used unambiguously is allowed by IUPAC.

Let us now study the sequence rules used in Cahn-Ingold-Prelog system. These rules are given below:

1. Atoms of the higher atomic number have higher priority. For example, oxygen (At. No. 8) has higher priority than carbon (At. No. 6) which in turn has higher priority than hydrogen (At. No. 1).
2. When the priority is to be decided between the atoms which are isotopes of the same element, then the isotope of higher atomic mass has higher priority. Therefore, deuterium ( ${}^2_1\text{H}$ ), an isotope of hydrogen has higher priority than hydrogen ( ${}^1_1\text{H}$ ).

When the two groups attached to the carbon atom involved in the formation of double bond have the same atoms as points of attachment, then the priorities are assigned according to the first point of difference, applying the same considerations of atomic number and atomic mass. To understand this, consider that the two groups attached to the carbon atom involved in the formation of double bond are ethyl and propyl groups, as shown below:

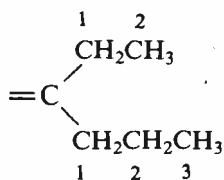

Here both these groups are attached to the carbon atom forming the double bond by carbon atoms. To decide which of the two will have higher priority, look at the substituents on C-1 carbon atoms of the ethyl and propyl groups. You will find that in both the groups, two hydrogens are attached to the C-1 carbon atom. Let us move to the next carbon, C-2. In case of the ethyl group, there are three hydrogens attached to C-2 carbon while the propyl group has two hydrogens and one carbon attached to the C-2 carbon. Clearly, then this is the first point of difference where the C-2 carbon of propyl group has the substituents C, H, H while that of the ethyl group has the substituents H, H, H. Hence, the propyl group has priority over the ethyl group.

4. When we come across double or triple bonds while assigning the priorities, then these groups are visualised in such a way that the bonded atoms are duplicated or triplicated as the case may be. For example, in the group

$-\text{HC}=\text{C}\text{H}_2$ , a carbon atom attached to another carbon atom by a double bond is considered to be bonded to two carbon atoms. Thus, this group can be regarded as

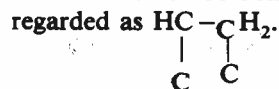

Similarly, the  $-\overset{\text{O}}{\parallel}{\text{C}}-\text{H}$  group is treated as equivalent to  $-\overset{\text{O}-\text{C}}{\parallel}{\text{C}}-\text{H}$ .

This is a kind of expansion of the groups in such a way that each atom is shown as linked to the other atom by a single bond. Thus, to write for the group shown below,

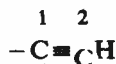

first expand at C-1 carbon which has all the three bonds linked to the carbon atom numbered as C-2. Thus, it is to be shown as if it is linked to three carbon atoms like this,

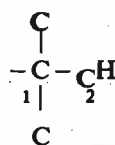

Now repeat the same for the C-2 carbon, which is expanded to yield,

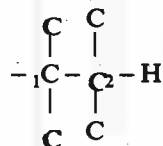

which is the equivalent form of  $-\text{C}\equiv\text{CH}$  group considered for assigning the priority.

In the guidelines provided by these sequence rules, some commonly occurring groups can be arranged in the decreasing order of their priority as follows:

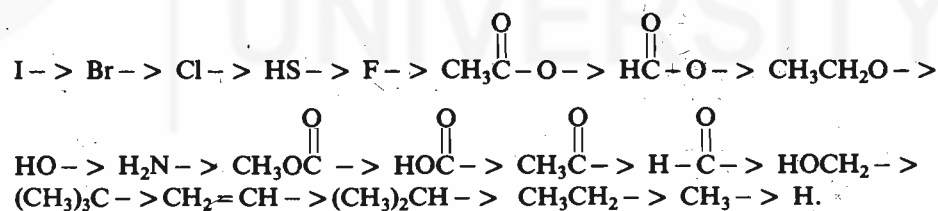

Let us now study some examples which illustrate how a given compound is designated as *E* or *Z*, using the above sequence rules.

#### Example 1

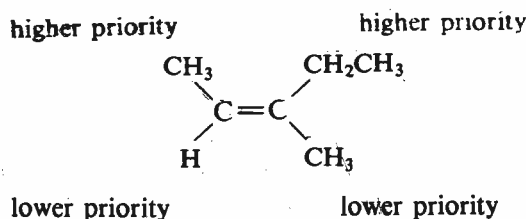

In this compound, groups of higher priority are on same sides of the double bond, hence, it is the (*Z*)-isomer.

Example 2 :

lower priority

higher priority

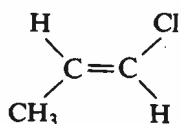

higher priority

lower priority

In this case, groups of higher priority are on opposite sides of the double bond, hence, it is the (*E*)-isomer.

Similarly, the isomer shown below,

higher priority

lower priority

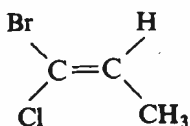

lower priority

higher priority

is (*E*)-isomer and can be named as (*E*)-1-bromo-1-chloropropene.

And, the isomer

higher priority

higher priority

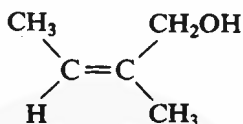

lower priority

lower priority

is (*Z*)-isomer.

Similar to the geometrical isomerism exhibited about a double bond, the compounds having a cyclic rigid framework can also show geometrical isomerism. Some cyclic compounds which exhibit geometrical isomerism are shown below.

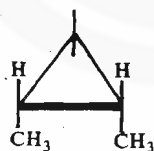

*cis*-1,2-dimethylcyclopropane

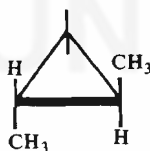

*trans*-1,2-dimethylcyclopropane

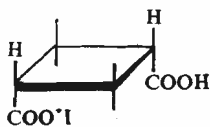

*cis*-1,3-cyclobutanedicarboxylic acid

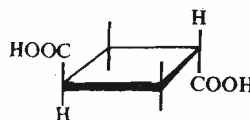

*trans*-1,3-cyclobutanedicarboxylic acid

You will study more about the stereochemistry of simple cyclic compounds such as cyclohexanes in the next unit. However, the general aspects of the chemistry of cycloalkanes will be dealt with in Unit 6 of Block 2 of this course.

Geometrical isomers vary widely in their physical properties. Physical properties of some geometrical isomers are listed in Table 2.1.

Activity

Make models for *cis*- and *trans*-isomers of 1,2-dimethylcyclopropane and convince yourself that all the three carbon atoms of the cyclopropane are in one plane and the methyl groups are located perpendicular to the plane of the ring. Thus, in the *cis*- isomer, both the methyl groups are either above or below the plane of the molecule but in the *trans*- isomer one methyl group is above the plane of the molecule and other is below the plane of the molecule.

Table 2.1: Physical properties of some geometrical isomers

Compound	Melting point (K)	Boiling point (K)	Dipole moment
			$10^{-30}$ (C m)
<i>cis</i> -2-butene	134	277	1.10
<i>trans</i> -2-butene	167	274	0
<i>cis</i> -1,2-dichloroethene	193	333	6.17
<i>trans</i> -1,2-dichloroethene	223	321	0
<i>cis</i> -1,2-dibromoethene	220	383	4.5
<i>trans</i> -1,2-dibromoethene	267	381	0
<i>cis</i> -1,2-diiodoethene	259	345	2.50
<i>trans</i> -1,2-diiodoethene	461	465	0

In the next section, we will use these physical properties to characterise geometrical isomers. But before that answer the following SAQ.

**SAQ 2**

Assign the configuration as *E* or *Z* to the following compounds.

i)

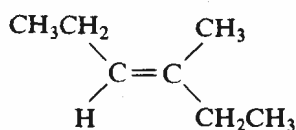

ii)

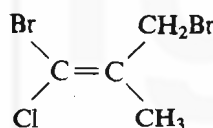

iii)

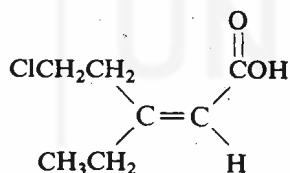

iv)

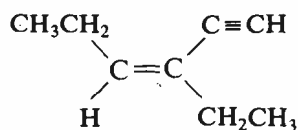

## 2.4 CHARACTERISATION OF GEOMETRICAL ISOMERS

geometrical isomers. Let us first study the characterisation of geometrical isomers based on their physical properties and then we will study how chemical properties can be used for the characterisation of these isomers.

The geometrical isomers or the *cis-trans*- isomers differ from each other in their physical properties like melting point, boiling point, dipole moment and spectral characteristics. Table 2.1 clearly shows that the *trans*- isomer has a higher melting point than the corresponding *cis*- isomer. The reason for this is that the *trans*- isomer being more symmetrical, fits into the crystal lattice more easily and hence, has a higher melting point than the *cis*- isomer. However, the correlation of boiling points with configuration of the isomer is not as exact as is the case with melting points, because of its dependence on molecular volume. Hence, boiling points are not of much use for such determinations.

Another physical property useful for such differentiation is dipole moment. In geometrical isomers of the type  $abC=Cab$ , the *trans*- isomer has zero dipole moment. Some such examples are listed in Table 2.1. This is so because in the *trans*- isomer, the same substituents are located in the opposite directions and hence whatever be the magnitude of dipole moment due to one bond in one direction, it is cancelled by an equal moment operating in the opposite direction; thus, the resultant dipole moment is zero. Depending upon whether the substituents are electron-withdrawing or electron-donating, the directions of the dipole moments due to individual bonds for the *trans*- isomer are as given below.

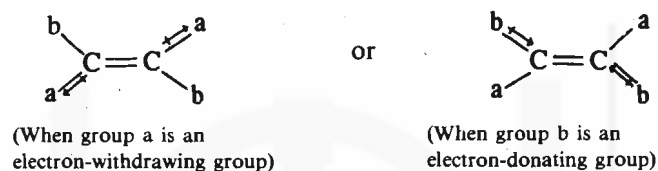

However, the resultant dipole moment,  $\mu$ , for both the cases is zero.

But in the *cis*-isomer, depending upon whether the groups are electron-donating or electron-withdrawing, the direction of individual bond moments is as shown below:

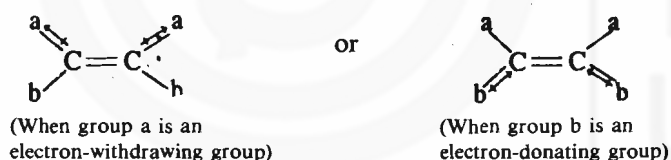

In both these situations, the individual dipole moments add vectorially leading to a definite resultant dipole moment. Hence, the molecule is said to have some dipole moment. You can check from Table 2.1 that the *cis*- compounds of this type always have some definite positive value for the dipole moment.

Let us next consider a molecule in which one substituent is electron-donating and the other is electron-withdrawing. Let X be an electron-donating substituent and Y be an electron-withdrawing substituent. The bond moments in the geometrical isomers of this type are shown below:

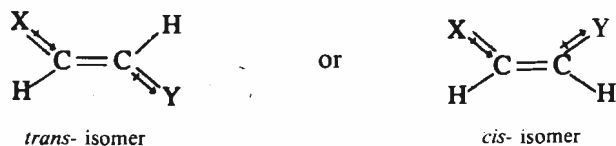

In case of the *trans*- isomer, the bond moments add vectorially and reinforce each other leading to higher dipole moment for this isomer. The vectorial addition for the *cis*- isomer leads to a lower value for the resultant dipole moment. This is illustrated in the example given below.

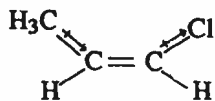

*cis*-1-chloro-1-propene  
 $\mu = 5.70 \times 10^{-30} \text{ C m}$

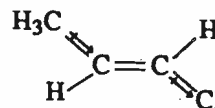

*trans*-1-chloro-1-propene  
 $\mu = 6.56 \times 10^{-30} \text{ C m}$

The differentiation of geometrical isomers using spectral properties will be dealt with in Unit 7 of Block 2.

For a particular pair of geometrical isomers, the functional groups present are the same; hence, it is difficult to distinguish them on the basis of their chemical reactions. But there are some reactions which are possible with one isomer only because of the spatial arrangement of its groups. One such reaction is the formation of an anhydride by the maleic acid which is the *cis*- isomer of

An acid anhydride is formed by the elimination (or loss) of a water molecule from an acid. A dicarboxylic acid can lose a molecule of water and form an anhydride easily only if the carboxyl ( $-\text{COOH}$ ) groups are on the same side of the molecule.

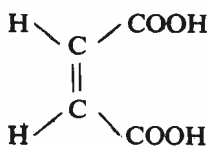

maleic acid  
 (*cis*-isomer)

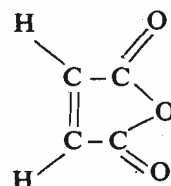

maleic anhydride

**Activity**

Make models of maleic acid (*cis*-but-2-ene-1,4-dioic acid) and fumaric acid (its *trans*- isomer) and convince yourself that the two carboxyl ( $-\text{COOH}$ ) groups are close to each other in the *cis*-isomer whereas they are far apart in the *trans*- isomer.

but-2-ene-1,4-dioic acid. The two carboxyl ( $-\text{COOH}$ ) groups are in close proximity in this isomer and hence can yield an anhydride by the elimination of a molecule of water. But, in the *trans*- isomer, i.e. in fumaric acid, since the two carboxyl groups are in opposite directions, such a reaction is not possible and hence it does

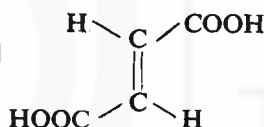

→ Anhydride formation is not possible

not form its own anhydride. However, when strongly heated, it forms the anhydride of maleic acid. Thus, we can differentiate between the *cis*-and the *trans*-isomers on the basis of chemical reactivity.

Before proceeding to the study of optical isomerism in the next section, you can check your understanding of geometrical isomerism by answering the following SAQ.

**SAQ 3**

a) Write the geometrical isomers of *o*-hydroxycinnamic acid having the following structure.

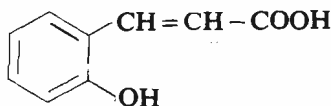

.....  
 .....

b) Which of the two isomers of *o*-hydroxycinnamic acid would undergo cyclisation easily to yield the following lactone:

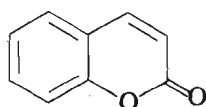

coumarin

Give reason for your answer.



**Hint:** Note that the coumarin is formed by the loss of water; for removal of water, H and OH groups to be removed as water must remain spatially near to each other.

.....

.....

## 2.5 OPTICAL ISOMERISM

As pointed out earlier, optical isomerism is manifested by the rotation of the plane of plane-polarised light. Let us first understand what is plane-polarised light and then see how it is used in the determination of optical activity.

### 2.5.1 Plane-polarised Light and Optical Activity

You are already familiar with the fact that light can be regarded as an electromagnetic radiation having oscillating electric and magnetic fields associated with it. The vectors describing these electric and magnetic fields are at right angles to each other (see Fig. 6.4, Unit 6, Block 2 of Atoms and Molecules course).

Ordinary light consists of light waves of different wavelengths. A monochromatic light (light having a single wavelength having  $\lambda = 589$  nm, called sodium D line) obtained from the sodium lamp is used in the experiments. This monochromatic light still vibrates in many different planes as shown in Fig. 2.1 (a).

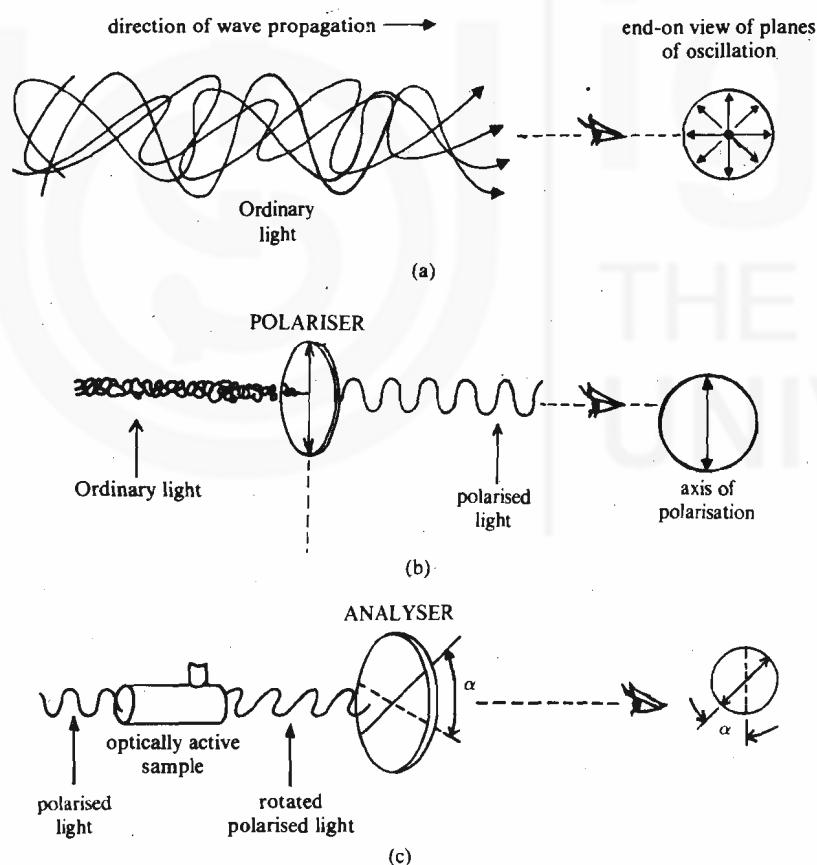

Fig. 2.1 : a) Ordinary light. b) Plane-polarised light. c) Rotation of plane of plane-polarised light.

Such a light is called unpolarised light. When a beam of monochromatic light is passed through a polariser such as a polaroid lens or a device known as Nicol prism, the light, (i.e. its electric field) vibrating in **only one plane** is obtained. Such a light is called **plane-polarised light** [see Fig. 2.1. (b)]. It was observed that many substances such as quartz crystals and organic compounds like camphor and tartaric acid rotated the plane of plane-polarised light [Fig. 2.1 (c)]. Such substances are called **optically active**. The instrument used for the determination of optical activity is known as *polarimeter*.

Nicol prism, is named after its discoverer Nicol who passed ordinary light through a prism made by cementing two pieces of crystalline calcium carbonate, also known as Iceland spar, at specific angles to obtain plane-polarised light.

A schematic diagram of a polarimeter is shown in Fig. 2.2.

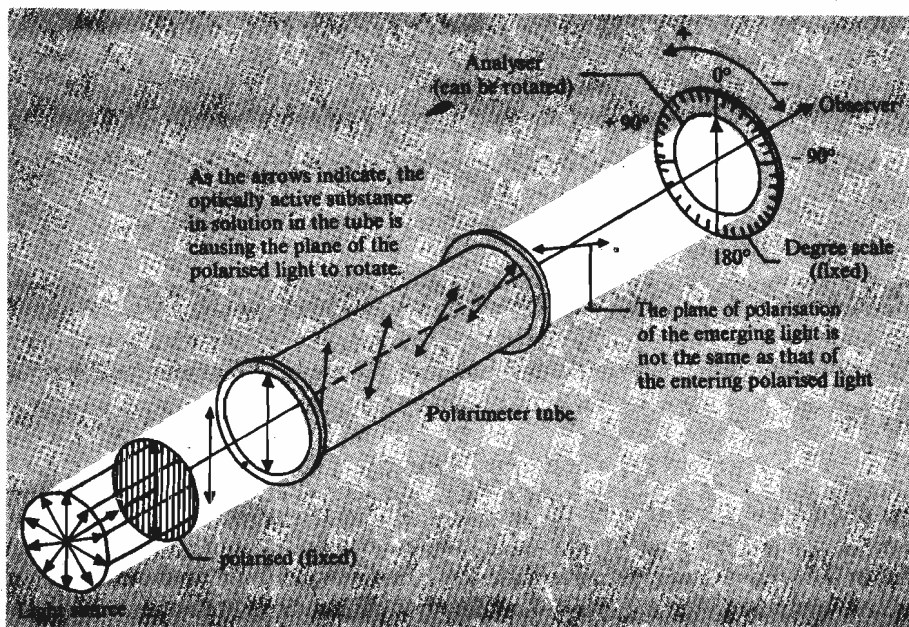

Fig. 2.2 : A schematic diagram of a polarimeter.

$$1 \text{ kg dm}^{-3} = 1 \text{ gm ml}^{-3}$$



electric vectors of a beam of unpolarised light



direction of the electric vector of plane polarised light as it leaves the polariser



Dextrorotation:  
plane of polarisation rotated clockwise:  
angle of rotation = + α



Levorotation:  
plane of polarisation rotated counterclockwise:  
angle of rotation = - α

For an optically active compound, the extent of rotation,  $\alpha$ , depends upon thickness of the sample (which is given by the length of the cell,  $l$ ), its concentration ( $c$ ), solvent, temperature and wavelength of the light used. When  $l$  is taken in decimetres and  $c$  is taken in  $\text{kg dm}^{-3}$ , then the rotation in degrees is termed as **specific rotation** and is denoted by  $[\alpha]$ . Thus, specific rotation can be calculated using the following expression,

$$[\alpha] = \frac{\alpha}{l \times c} \quad \dots(2.1)$$

The temperature,  $t$  and the wavelength,  $\lambda$ , of the light used are specified as superscript and subscript, respectively. The solvent and the concentration of the solution are given in brackets. Hence, the specific rotation of a sample is expressed as,

$$[\alpha]_t^\lambda \text{ (solvent, } c)$$

Thus,  $[\alpha]_D^{293}$  denotes the specific rotation at the temperature 293 K when the measurement is done using the D line of sodium having  $\lambda = 589 \text{ nm}$ .

The direction of rotation is specified as **dextrorotatory** or **levorotatory**. When a compound rotates the plane of polarised light in the clockwise direction, it is called **dextrorotatory** and this positive rotation is denoted by the plus (+) sign prefixed to the name of the compound. On the other hand, the compound rotating the plane of polarised light in the anticlockwise direction is called **levorotatory** and such a rotation is taken as rotation in the negative direction. Hence, it is indicated by prefixing a minus (-) sign to the name of the compound. Earlier the letters  $d$  and  $l$  were used to denote the dextrorotation and levorotation, respectively.

Let us now study why some compounds are optically active and the others are not.

### 2.5.2 Origin of Optical Activity

The origin of optical activity can be traced back to the observations of the French physicist Biot who in 1813 discovered the existence of two types of quartz crystals (shown in Fig. 6.5, Unit 6, Block 2, Atoms and Molecules course). One type of crystals rotated the plane of polarised light to the left and the other type to the right. After two years, he observed that such optical activity is not restricted to the **crystalline structure** and some compounds such as camphor and tartaric acid exhibited optical activity even in **solution**. He also realised that optical activity in solution is due to some molecular property which is retained even in solution. Later Pasteur studied tartaric acid and its nineteen different salts and observed that

two types of crystals of tartaric acid existed; one being right-handed with respect to certain faces and other being left-handed. These two types of crystals were mirror images of each other. Pasteur proposed that since the optical activity is retained in the solution phase also, it must be a property of the molecules themselves and just as the crystals of quartz are mirror images of each other, the molecules, of which these crystals are formed, are also mirror images of each other. This led to the possibility of the existence of compounds whose molecules are mirror images of each other. These mirror image isomers being otherwise identical, exhibit identical physical properties; even the extent of rotation of the plane of polarised light is the same for such pairs. The only difference in their physical properties is in the direction of rotation of plane-polarised light: one isomer being dextrorotatory and the other being levorotatory.

Table 2.2 gives the physical properties for the mirror image isomers of 2-octanol.

Table 2.2 : Physical properties of isomeric 2-octanols

Physical property	(-)-2-Octanol	(+)-2-Octanol
Specific rotation $[\alpha]_D^{290}$	-9.9°	+9.9°
Boiling point (K)	448	448
Refractive index $n_D^{298}$	1.4254	1.4258
Specific gravity $d_4^{293}$	0.838	0.822

The next question that you may ask is: What kind of molecules are capable of existing as mirror image isomers? The answer is that the molecule and its mirror image isomer should be nonsuperimposable. Such nonsuperimposable mirror image isomers are called **enantiomers**. Thus, for a compound to exist as two enantiomers, nonsuperimposability of mirror image structures is a condition.

The most general example that helps to understand enantiomerism is the nonsuperimposability of our hands as shown in Fig. 2.3. You can see that the two hands are mirror images of each other but they are not superimposable on each other. This becomes more obvious if we try to put the right hand glove on the left hand and vice versa.

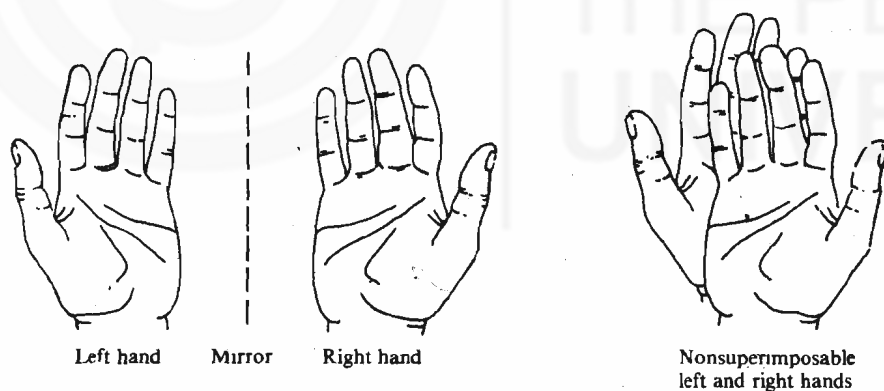

Fig. 2.3 : The nonsuperimposability and enantiomeric relationship of left and right hands.

In the Greek language the word **cheir** means *hand* and hence a molecule which is nonsuperimposable on its mirror image is said to be **chiral** and the term **chirality** means showing handedness. Thus, chirality is a necessary and sufficient condition for the existence of enantiomers. On the other hand, when a molecule is superimposable on its mirror image, it is said to be **achiral**. Let us now study some aspects of chirality in detail.

### 2.5.3 Chirality

The satisfactory explanation at the molecular level for the origin of optical activity (or existence of enantiomers) was given by van't Hoff and Le Bel simultaneously and independently in 1874. van't Hoff realised that it was necessary to think of molecular structures in three dimensions in order to solve the problem of isomers

To decide whether the two given mirror image structures are enantiomers or are molecules of same isomer, try to superimpose one over the other. If they are superimposable, they are the molecules of the same isomer and if they are nonsuperimposable, they are enantiomers.

Chiral is pronounced as ki-rall.

Handedness means existence of nonsuperimposable mirror image structures.

Only chiral molecules can exist as enantiomers.

The enantiomers have opposite chirality.

The first Nobel Prize in Chemistry in 1901 was awarded to van't Hoff.

that were being discovered in the laboratory. He proposed that a carbon atom with four different substituents arranged tetrahedrally around it, would account for the existence of enantiomers. The tetrahedral arrangement of groups about the carbon atom makes it possible to have left- and right-handed structures (or isomers). The phenomenon of optical activity thus finds a satisfactory explanation in the tetrahedral geometry of saturated carbon compounds. Le Bel suggested that a carbon atom with four different substituents around it is the basis of optical activity but he did not specify the tetrahedral arrangement. Thus, in the case of lactic acid in which all the four substituents, i.e. H, CH<sub>3</sub>, OH and COOH attached to the carbon atom, are different and are arranged tetrahedrally around it, two isomers are possible (see Fig. 2.4). These isomers being the nonsuperimposable mirror image isomers, are enantiomers.

**Activity**  
Make models of the enantiomers of lactic acid and convince yourself that they are nonsuperimposable on each other.

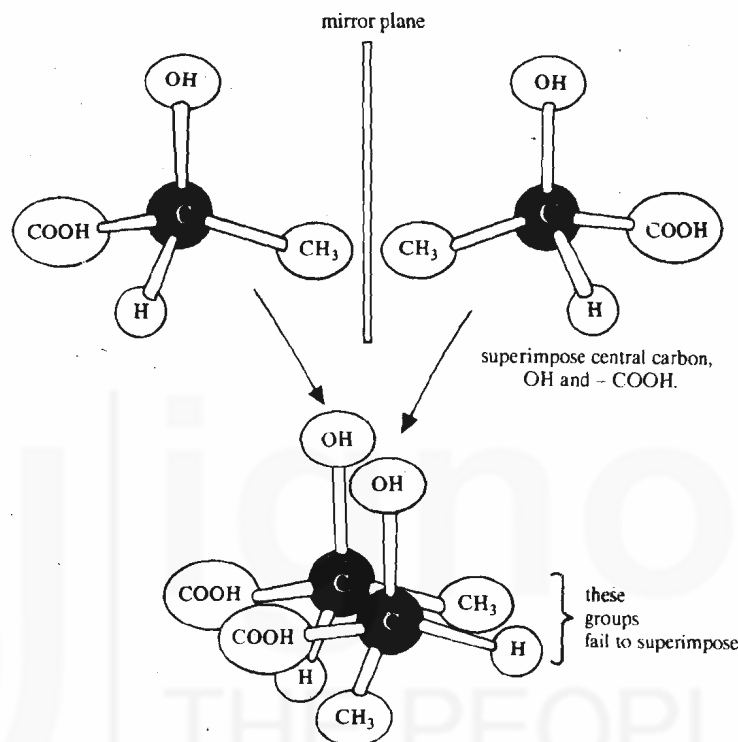
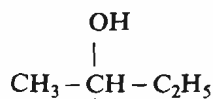
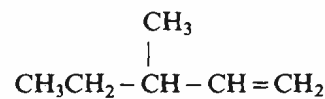

Fig. 2.4 : Enantiomers of lactic acid.

Hence, lactic acid is a chiral molecule and it is said to exhibit chirality. Such molecules which have four different substituents attached to a carbon atom are called **asymmetric**, i.e. they are without symmetry. To decide whether a given structure or a molecule has symmetry or not, we will study the elements of symmetry in the next section. The tetrahedral carbon atom bearing the four different substituents is variously referred to as a **asymmetric centre** or a **chiral centre**. Since it is the molecule itself which is chiral rather than one of its atoms, it has been suggested it is more correct to call the carbon atoms of this type as **stereocentres**. The IUPAC rules for stereochemical notation use the term chiral centre. Given below are some asymmetric compounds in which the chiral centre is shown by an asterisk (\*) mark.



2-butanol



3-methyl-1-pentene

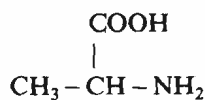

alanine

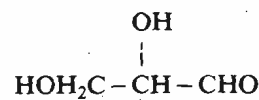

glyceraldehyde

Remember that a carbon atom forming a double bond cannot be a chiral centre because it cannot have four different substituents.

Till now we were dealing with the compounds having only one chiral centre. Let us now study what happens when there is more than one chiral centre in a molecule.



find that they are **superimposable**. Thus, they are not different but are identical; hence, **they represent the two molecules of the same isomer**. Thus, for tartaric acid we have only three isomers. In general for a compound having  $n$  chiral centres the number of possible stereoisomers is given by  $2^n$ . Thus, for a molecule having 2 chiral centres, 4 stereoisomers are possible. But, in some cases (as in tartaric acid), when the chiral centres are equivalently substituted, (i.e. the substituents on the chiral centres are the same), fewer isomers than predicted by  $2^n$ , exist. Of the above isomers, (V and VII) and (VI and VII) are diastereoisomers. Because the diastereoisomers are not mirror image isomers, hence, often they have different physical and chemical properties. Table 2.3 shows identical physical properties (except for the sign of rotation) for the enantiomers V and VI but their diastereomer VII (or VIII) has physical properties different from those of V or VI.

Table 2.3 : Some physical properties for the isomers of tartaric acid.

Physical Property	V	VI	VII (or VIII)
Melting point/(K)	441 – 443	441 – 443	419 – 421
Density/(kg dm <sup>-3</sup> )	1.7598	1.7598	1.666
$[\alpha]_D^{293}$	+12	-12	0

Table 2.3 shows that the compounds having structures V and VI are optically active but that corresponding to VII or VIII is not, although, it also has two chiral centres. Why is this so? You will find an answer to this question in the next section. But before studying that, answer the following SAQ.

#### SAQ 4

Write the stereoisomers for the compound  $\text{HOH}_2\text{CCHOHCHOHCHO}$  and group them as enantiomers and diastereomers.

.....

.....

.....

.....

## 2.6 CHIRALITY AND ELEMENTS OF SYMMETRY

A general test of **chirality** which you learnt in the last section is the nonsuperimposability of the molecule and its mirror image. However, there is another simple way to examine the molecules for the **absence** of chirality. Molecules which are not chiral (or are **achiral**), possess one or more elements of symmetry. There are mainly three elements of symmetry, namely, plane of symmetry, centre of symmetry and alternating axis of symmetry. Let us study these elements of symmetry one by one.

**Plane of Symmetry:** A plane of symmetry is defined as an imaginary plane which divides the molecule into two halves which are mirror images of each other. Some objects having the plane of symmetry are shown in Fig. 2.5.

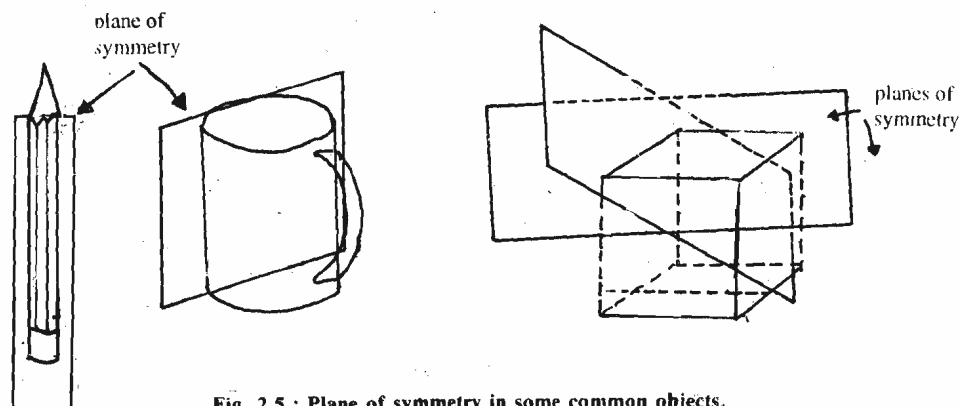

Fig. 2.5 : Plane of symmetry in some common objects.

**Centre of symmetry:** A centre of symmetry is a point such that any line drawn from this point to some other point (or group) in one direction, when extended at equal distance in the opposite direction, should find an identical point (or group). Such a centre of symmetry is shown in Fig. 2.6.

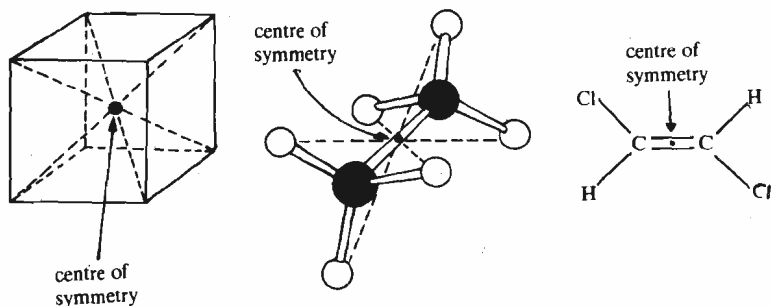
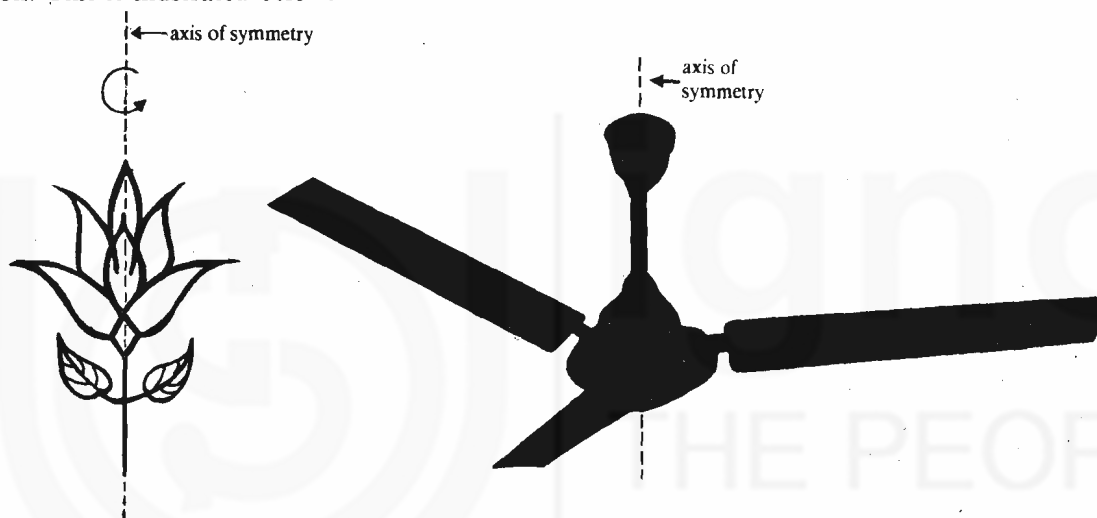

Fig. 2.6 : Centre of symmetry in (a) a cube; (b) ethane and (c) *trans*-1, 2-dichloroethene.

**Axis of symmetry:** When a structure possessing this axis is rotated around this axis, another identical structure results. In case the identical structures result twice on rotation of the molecule by 360°, the axis is called a **two-fold axis** of symmetry and when identical structures repeat three times, it is called a **three-fold axis** and so on. This is illustrated below:



Two-fold axis of symmetry as the leaf appears twice on rotation by 360°

Three-fold axis of symmetry in a ceiling fan; the blades appear at equivalent positions thrice on a single rotation.

When such identical points alternate around a plane or an axis, then the axis of symmetry is called an **alternating axis of symmetry**. For example, 1,3-dichlorocyclobutane has two fold alternating axis of symmetry and not the simple axis of symmetry, because when rotated around this axis although the Cl group appears twice, one of them appears **above** the plane of the molecule and the other appears **below** the plane.

A molecule having a plane of symmetry or a centre of symmetry or an alternating axis of symmetry is superimposable on its mirror image and, hence, is not chiral. Note that absence of alternating axis of symmetry is important and not just of the simple axis of symmetry. For example, a molecule having a simple axis of symmetry can show optical activity or chirality. Take models of the enantiomers of tartaric acid, shown in Sub-Sec 2.5.3 as structures V and VI (these models you have made earlier also) and convince yourself that both of them have a two-fold simple axis of symmetry but still they are optically active (see Figure at next Page).

Let us now go back to the problem we left unanswered at the end of the last section. Since, the third isomer of tartaric acid, represented by structure VII, has a **plane of symmetry**, it is optically inactive. This plane can be easily visualised by looking at the model of structure VII. Such compounds in which one half of the molecule is the mirror image of the other half, are called **meso** compounds. Thus, **meso**-tartaric acid represented by structure VII (or VIII), has two chiral centres but as it has a plane of symmetry, the optical activity caused by one chiral centre

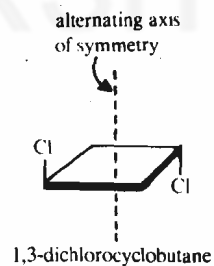

The word *meso* means middle or inbetween.

is cancelled by the other chiral centre. This is so because the two halves, being the mirror images of each other, have equal and opposite rotation. Hence, *meso* compounds are optically inactive.

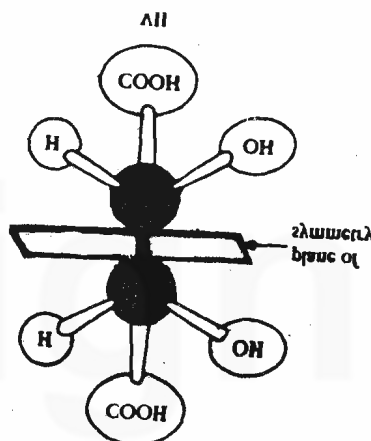
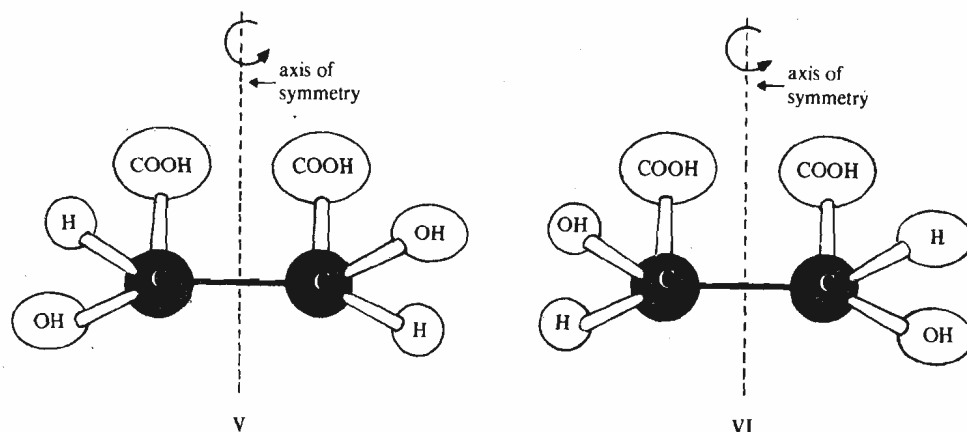

A *meso* compound is optically inactive due to *internal compensation*; optical activity due to one half of the molecule is cancelled by that due to the other half.

In other words, if one half of the molecule causes a rotation of  $+X^\circ$  and the opposite half causes a rotation of  $-X^\circ$ , then it leads to a zero rotation for the molecule or no optical activity. This type of cancellation is called *internal compensation*. There is another way in which compounds containing chiral centres can behave as optically inactive. You will study about this in the next unit. You can apply your knowledge about the elements of symmetry in answering the following SAQ.

**SAQ 5**

Which of the following are chiral?

- a) a shoe

.....

- b) a book

.....

- c) methane molecule

.....

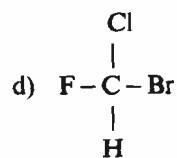

.....



## 2.7 SUMMARY

In this unit, we learnt that

- Stereoisomers differ from each other in the arrangement of their atoms in space.
- Geometrical isomers can be named according to *cis-*, *trans-* or *E*, *Z* nomenclature.
- There are two types of optical isomers: enantiomers which are mirror image isomers and diastereoisomers which are stereoisomers other than enantiomers.
- Enantiomers have **identical** physical properties (except the direction of optical rotation) but diastereoisomers have different physical properties.
- Molecules having one chiral centre can exist as enantiomers. However, molecules having more than one chiral centre may or may not be optically active, e.g., *meso* compounds are optically inactive.
- The tetrahedral nature of carbon was postulated on the basis of the observations of optical activity.

## 2.8 TERMINAL QUESTIONS

1. Write structural formulas for each of the following compounds. Be sure that you write the correct stereochemistry.

- (*Z*)-5-chloro-2-pentene
- trans*-1,2-dimethylcyclopropane
- meso*-2,3-dibromobutane
- cis*-1,2-dichlorocyclopentane

2. Look at the following pairs of compounds carefully and state which type of isomerism they exhibit.

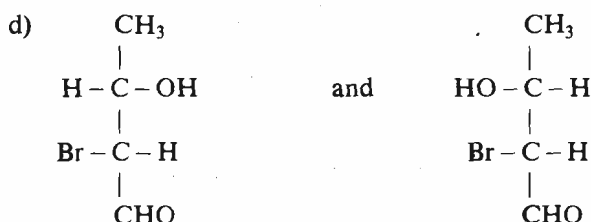
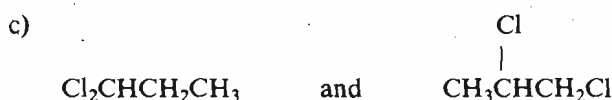
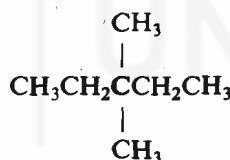
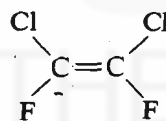
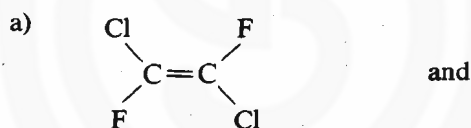

3. a) Locate the chiral carbon atoms in the following compounds and mark them with asterisk.

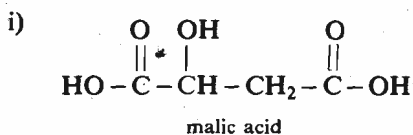

ii)

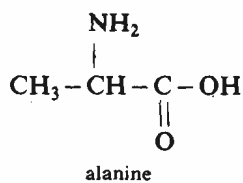

iii)

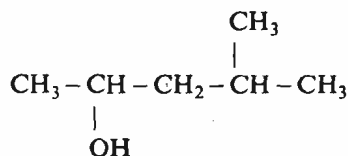

b) Write the structures for the enantiomers of the compounds given in (a).

4. What elements of symmetry are present in the following?

- a) a ball                      b) a cube                      c) scissors  
d) letter X                      e) methane                      f) methylchloride.

5. How many *meso* stereoisomers are possible for 2,3,4-pentanetriol? Write their structures.

## 2.9 ANSWERS

### Self Assessment Questions

1. Structural isomers having molecular formula  $\text{C}_3\text{H}_8\text{O}$  are as given below.

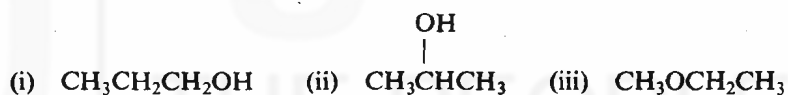

2. i) *E*      ii) *Z*      iii) *Z*      iv) *Z*

3.

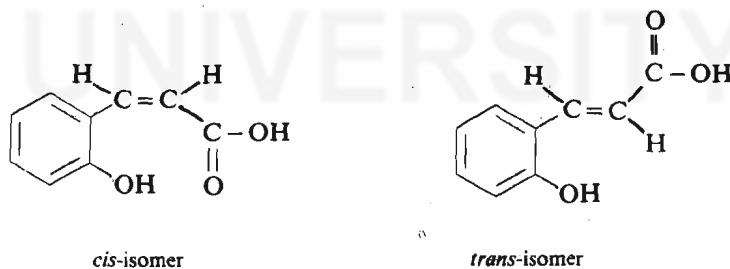

Since  $-\text{OH}$  and  $-\text{COOH}$  groups are in close proximity in *cis-isomer*, it can yield the required coumarin by loss of a water molecule.

4.

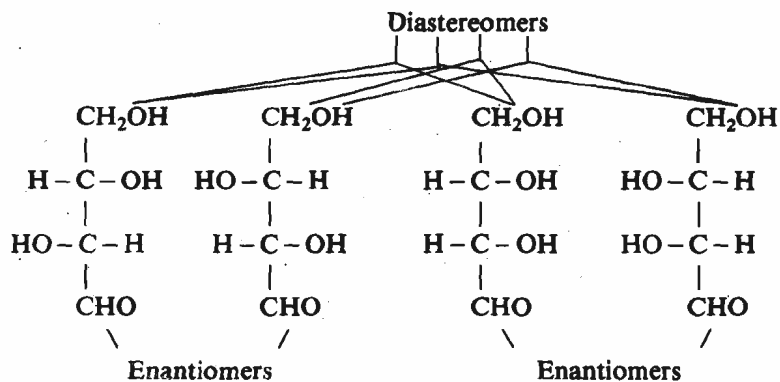

5. (a) and (d) are chiral.

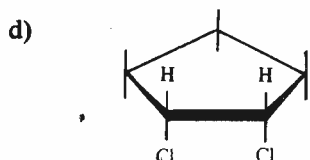
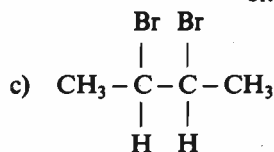
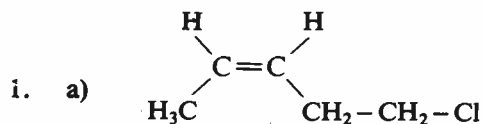

2. a) geometrical  
b) chain  
c) position  
d) optical (diastereomers)

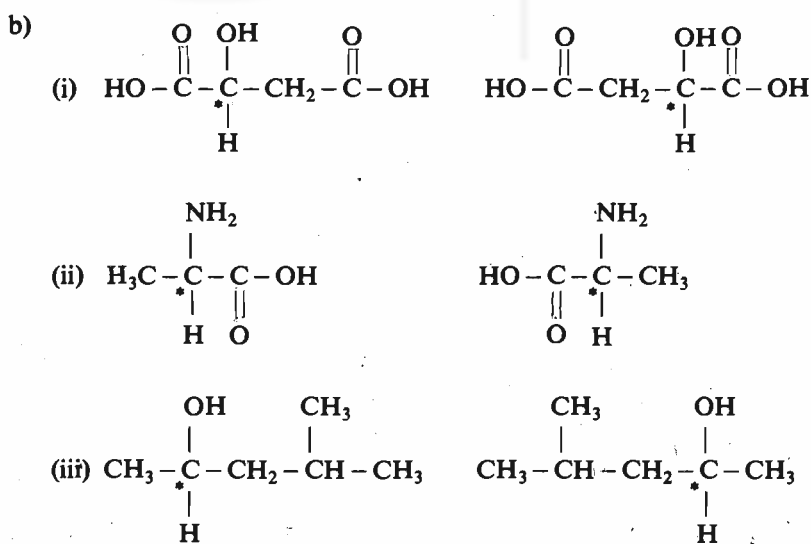
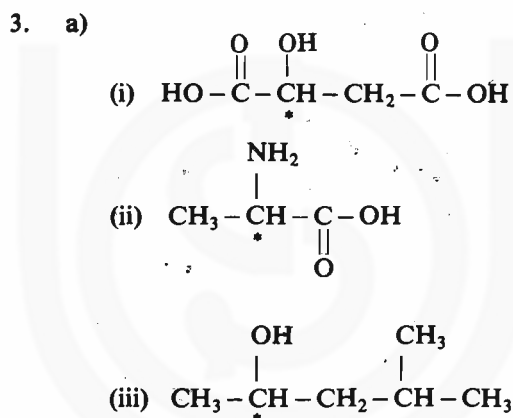

4. a) plane, centre and axis of symmetry  
b) plane, centre and axis of symmetry

- c) plane of symmetry
  - d) plane, centre and axis of symmetry
  - e) plane and axis of symmetry
  - f) plane and axis of symmetry
5. The two *meso* stereoisomers of 2,3,4-pentanetriol are,

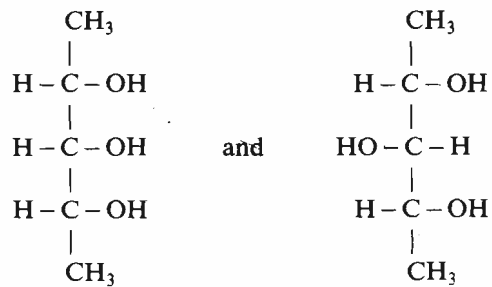

---

## UNIT 3 STEREOCHEMISTRY – II

---

### Structure

- 3.1 Introduction
  - Objectives
- 3.2 Configuration and Fischer Projection Formulas
- 3.3 Configurational Notations
- 3.4 Racemic Mixtures and their Resolution
- 3.5 Asymmetric Synthesis
- 3.6 Walden Inversion
- 3.7 Conformational Isomers and their Representation
- 3.8 Conformations of Ethane
- 3.9 Conformations of Butane
- 3.10 Conformations of Cyclic Systems
  - Conformations of Cyclohexane
  - Conformations of Monosubstituted Cyclohexane Derivatives
  - Conformations of Disubstituted Cyclohexane Derivatives
- 3.11 Summary
- 3.12 Terminal Questions
- 3.13 Answers

---

### 3.1 INTRODUCTION

---

In Unit 2, you studied the geometrical and optical isomerism. The arrangement of atoms or groups in space about a rigid framework was referred to as 'configuration' in Unit 2. In geometrical isomerism you learnt that the geometrical isomers can be assigned the configuration as *cis*- or *trans*- and *E*- or *Z*-, depending upon the spatial arrangement of groups about the rigid framework. You also studied about the existence of optical isomers such as enantiomers and diastereomers. These optical isomers have different configurations.

In this unit, you will study how to designate the configuration of optical isomers. We will also discuss how configuration is affected in chemical reactions. Under the laboratory conditions, chemical reactions yield an equimolar mixture of the two enantiomers. Here, you will also learn how to separate these mixtures in order to obtain optically pure compounds.

Then we will shift the focus of our attention to conformational isomers and study the conformational isomerism of simple straight chain and cyclic hydrocarbons.

#### Objectives

After studying this unit, you should be able to:

- write Fischer projection formulas for simple organic compounds,
- assign the configuration as either *R* or *S* to the chiral centre in a compound,
- define a racemic mixture and give a method of resolution for such a mixture,
- define and give examples of asymmetric synthesis,
- describe Walden inversion,
- draw sawhorse and Newman projections for a given compound,
- illustrate the conformations for simple straight chain hydrocarbons like ethane and butane, and
- draw and compare the stabilities of the boat and chair forms of cyclohexane molecule and its derivatives.

---

### 3.2 CONFIGURATION AND FISCHER PROJECTION FORMULAS

---

The term *configuration* was used earlier in case of geometrical isomers to indicate the spatial arrangement of groups around a rigid framework. Similarly, the term



Emil Fischer  
(Received Nobel Prize in 1902)

A Fischer projection formula is a standard way of depicting tetrahedral carbon atoms and their substituents in two dimensions.

configuration as applied to optical isomers indicates the spatial arrangement of atoms or groups around the chiral centre.

You know that the actual molecules are three-dimensional in nature. So, the spatial arrangement of groups in a molecule, i.e. its configuration, can be specified either by making its three-dimensional model or by writing the corresponding projection formulas. Also, to specify the configuration of a molecule having several chiral centres, the configuration at each chiral centre needs to be specified.

This specification of configuration for a molecule becomes more and more difficult as the number of chiral centres goes on increasing. Thus, a need was felt for a convention to represent the actual three-dimensional structure of molecules in two dimensions, (i.e. in the plane of the paper) in a simple and convenient way. The German chemist Fischer introduced such a convention. He called his representations as projection formulas. These representations are now known after his name as **Fischer projection formulas**.

Before proceeding to the study of Fischer projection formulas, it is necessary to familiarise you with another representation known as *perspective drawing*. Such a representation is used to represent three-dimensional structures of molecules in two dimensions. Fig. 3.1(a) illustrates such a perspective drawing. In a perspective drawing, a broken wedge represents the bond which is **behind** the plane of the paper and the solid wedge represents the bond which points **towards** the observer in front of the plane of the paper. The other two bonds which are represented by ordinary lines show the substituents which are **in** the plane of the paper.

Let us now learn how to write Fischer projection formula of the molecule whose perspective drawing is shown in Fig. 3.1(a). It is better if you take the help of the models supplied to you. Make a model of such a molecule by attaching four different substituents to a tetrahedral carbon atom. Now look at the model in such a way that the two substituents which point **towards** you are in the **horizontal plane** and the other two substituents which point **away from** you are in the **vertical plane**, as shown in Fig. 3.1(a). You can see in Fig. 3.1(b) that the angle between the horizontal and vertical planes is a right angle. Hence, the substituents in the horizontal plane are **at right angles** to the substituents in the vertical plane. We can represent these two sets of substituents at right angles to each other in one plane (obviously plane of paper), by drawing two lines at right angles to each other. Then, the substituents are written in the position they appear to the observer, i.e. the substituents which are at left and right of the observer are written at left and

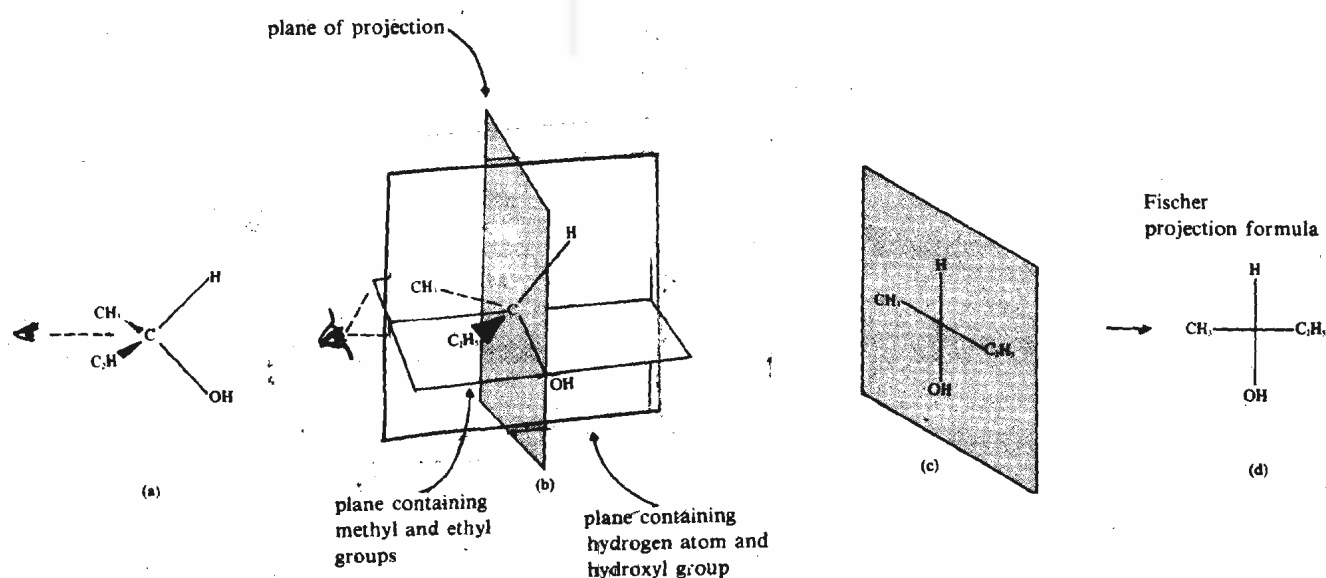

Fig. 3.1 : Writing Fischer projection formula for a molecule : (a) perspective drawing of a molecule having one chiral carbon atom; (b) two substituents each in horizontal and vertical planes at right angles to each other; (c) representation of molecule in plane of paper; and (d) the Fischer projection formula.

right, respectively, and the other two substituents which appear above and below are written at above and below positions, as shown in Fig. 3.1(c). Further, we can simplify Fig. 3.1(c) by removing the plane of paper shown in it and write the structure of the molecule as shown in Fig. 3.1 (d), which is nothing but the **Fischer projection formula** for the compound shown in Fig. 3.1(a). Note that the chiral centre is not shown in Fischer projections and it is assumed to be located at the point of intersection of the horizontal and vertical lines.

Similarly, the Fischer projection formula for one of the isomers of tartaric acid, shown in Fig. 3.2(a), can be written as shown in Fig. 3.2(b).

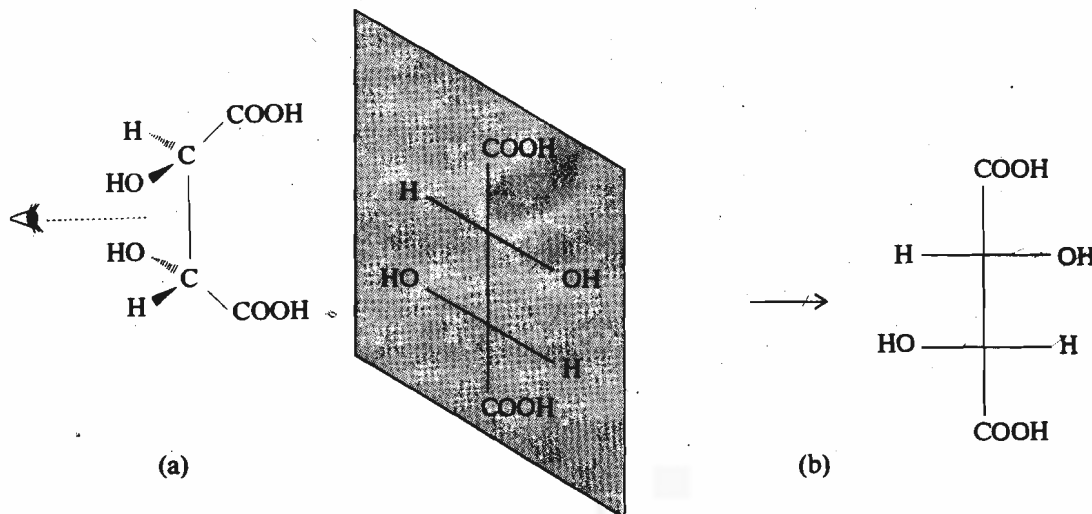
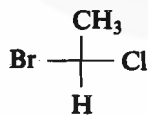

Fig. 3.2 : (a) An isomer of tartaric acid and (b) its Fischer projection formula.

The Fischer projections are very useful in case of molecules having many chiral centres linked together to form a continuous chain. You will realise in Unit 20 of Block 4 of this course the importance of these projection formulas in writing the structures of carbohydrates.

Let us now learn the reverse of what we have done above, i.e. write the three-dimensional structure of a molecule from its Fischer projections. For this, we have to reverse the process we have just described. **Always remember that in a Fischer projection formula the vertical lines represent the bonds that point away from you and the horizontal lines represent the bonds that point towards you.** Let us start with a molecule having the Fischer projections as given below,



The three-dimensional structure for this molecule can be written by using the following steps:

- i) Write a carbon atom at the intersection of the horizontal and vertical lines in Fischer projections, as shown below.

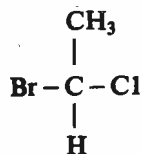

- ii) Since the vertical lines represent the bonds away from the observer and the horizontal lines represent the bonds towards the observer, we can write the structure of the molecule shown in step (i) as,

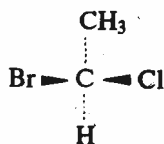

## Fundamental Concepts

While studying step (ii), use models for writing the perspective formula.

This can be translated into the perspective formula by viewing the molecule in such a way that the two substituents (say, CH<sub>3</sub> and Br) are parallel to the plane of the paper. In such a situation, H will appear behind the plane of the paper and Cl will appear projecting in front of the plane of the paper leading to the perspective drawing of the molecule as,

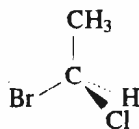

which leads to the following three-dimensional structure of the molecule.

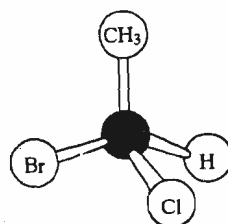

Different representations of (+)-2-bromobutane.

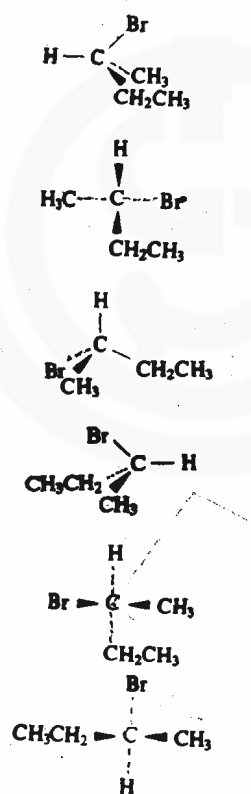

### How to interconvert Fischer Projections while maintaining the Configuration

Since there are many ways in which a given molecule can be oriented depending upon which two substituents are chosen to point towards the observer; hence, several different Fischer projections can be written for the same molecule. Let us go back to Fig. 3.1 and instead of viewing the molecule as shown in Fig. 3.1(a), now let us view the molecule in such a way that the substituents CH<sub>3</sub> and H point towards the observer. Thus, the substituents will now appear as shown below.

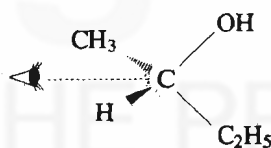

For this orientation of the molecule, the Fischer projection formula can be written as,

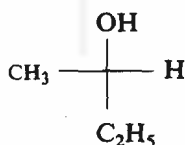

which is another Fischer projection formula for the same molecule as shown in Fig. 3.1(a). Because various Fischer projections are possible for a given molecule, you should have a clear understanding of writing different correct Fischer projections for a given molecule without going back and forth to the three-dimensional model. Therefore, you should be able to write different Fischer projections for the same molecule from its given Fischer projection formula. For this, there are some rules to be followed. These rules are as given below.

#### Activity

Make models of the molecules corresponding to the two Fischer projection formulas shown in rule 1. You can see that they represent the two Fischer projections of the same compound.

1. Rotation of the given Fischer projection formula by 180° in the plane of the paper yields another Fischer projection of the same molecule, i.e.,

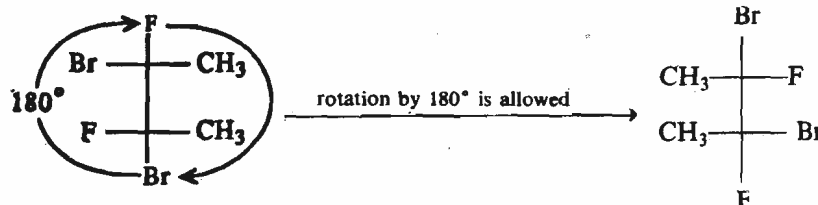



In other words, rotation of the Fischer projection in the plane of paper by  $180^\circ$  does not alter the configuration.

2. Rotation of a Fischer projection formula of a compound in the plane of the paper by  $90^\circ$  yields the Fischer projection formula of its enantiomer. It means that such a rotation leads to a change in the configuration at the chiral centre. This is illustrated in the following example.

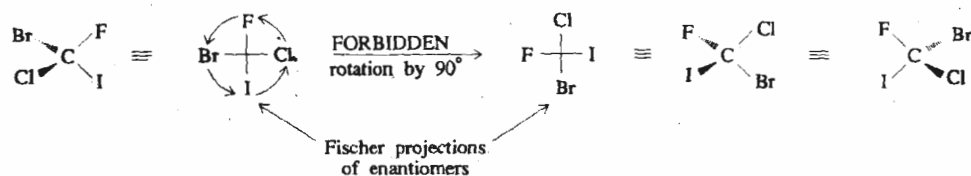

It is better to verify this rule with the help of the models.

3. A Fischer projection formula may **not** be lifted out of the plane of the paper and turned over as shown below.

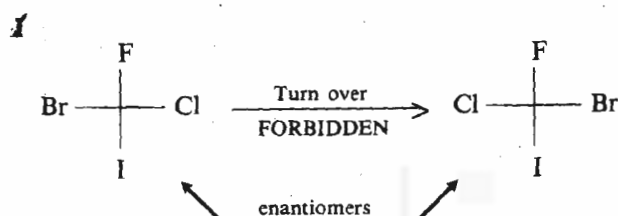

This turn over leads to the Fischer projection formula of the enantiomer. Thus, this operation on the Fischer projection changes the configuration at the chiral centre.

4. Interchange of two pairs of substituents leads to another Fischer projection of the same isomer. Hence, no change in configuration is observed by this operation. Let us understand this by the following example. If we have a molecule represented by the following Fischer projection,

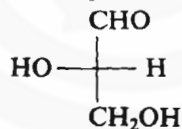

Interchange of one pair of substituents (i.e.,  $-\text{CHO}$  and  $-\text{CH}_2\text{OH}$ ) leads to the Fischer projection,

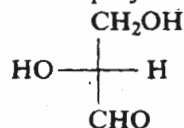

Another interchange of second pair of substituents leads to the Fischer projection as

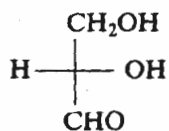

This when rotated by  $180^\circ$  yields

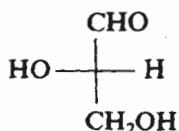

which is nothing but the same isomer we started with.

In the next section, you will learn about the specification of the configuration at a given chiral centre. Before that check your knowledge of Fischer projections, by answering the following SAQ.

## Activity

Make a model of a molecule having a chiral carbon atom linked to four different substituents 1, 2, 3 and 4 as shown below:

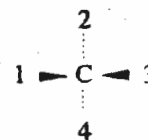

It has the following Fischer projections, given by (a).

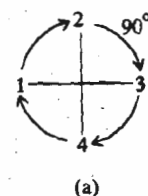

Rotate this Fischer projection by  $90^\circ$  to yield the following Fischer projections, shown as (b).

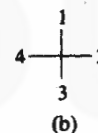

Make a model of the molecule corresponding to the Fischer projection formula shown in (b) as,

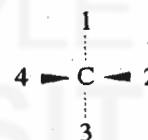

On comparing these two models, you will find that they represent the enantiomers.

## SAQ 1

Study each of the following pairs of Fischer projections carefully and decide whether they represent the same isomer or an enantiomeric pair.

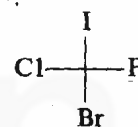
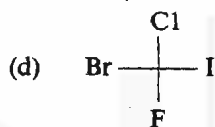
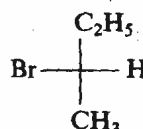
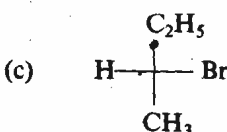
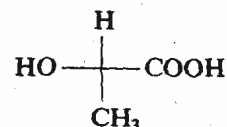
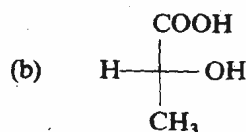
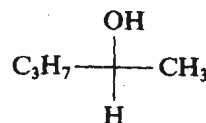
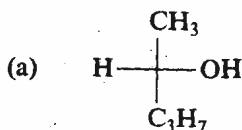

### 3.3 CONFIGURATIONAL NOTATIONS

The existence of enantiomers poses special problem of their nomenclature. As the enantiomers differ from each other in their sign of rotation, prefixes *d* and *l* were used earlier to designate the dextrorotatory and levorotatory isomers, respectively. But it was realised that the sign of rotation does not tell about the absolute configuration of the compound. Thus, to define the structure of a compound completely, it was necessary to specify the configuration at each chiral centre.

One of the earliest attempts to specify the configuration is that of Fischer which dates back to 1891. According to this system, the configuration at a particular carbon atom is designated by selecting a main chain in the molecule in the sense of the rules laid for nomenclature. The molecule is then oriented vertically in such a way that the carbon atom numbered 1 in the chain is at the top. Then, the main substituent attached to the chiral centre is looked for. For example, in glyceraldehyde, it is an -OH group. If in the Fischer projections of the compound the main substituent group is on the **right**, then the molecule is said to have **D** configuration and when this main substituent is on the **left**, then the molecule is said to have **L** configuration.

Rosanoff (1906) suggested that a particular configuration be assigned to (+)-glyceraldehyde. The Fischer projection corresponding to this configuration is given below.

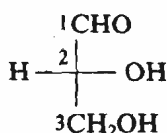

Thus, according to this system of designation of configuration as D or L, the carbon chain in (+)-glyceraldehyde can be numbered and oriented as shown above. Here, the substituent on the chiral centre is hydroxyl (-OH) group. Since it

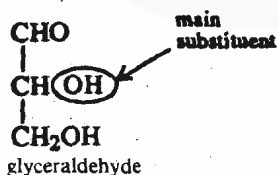

There is also a convention that the longest carbon chain forms the vertical backbone of the Fischer projections with the most highly oxidised carbon (if any) at the top; and then the substituents are projected horizontally.

Do not confuse *d* and *l* with D and L. The lower-case *d* and *l* were used in many places in older literature to specify the direction of rotation (synonymously with '+' and '-'). But D and L are used to specify the configuration at the chiral centre.

is on the right side, hence, (+)-glyceraldehyde has D configuration. Similarly, the enantiomer of (+)-glyceraldehyde, i.e. (-)-glyceraldehyde will have L configuration. Thus, we can designate the two enantiomers as D-(+)-glyceraldehyde and L-(-)-glyceraldehyde. Also all compounds having an arrangement of atoms similar to that at the chiral centre of (+)-glyceraldehyde at the corresponding carbon atom are members of the D family. Similarly, we can state for the L family. Some examples of compounds belonging to D and L families are listed below:

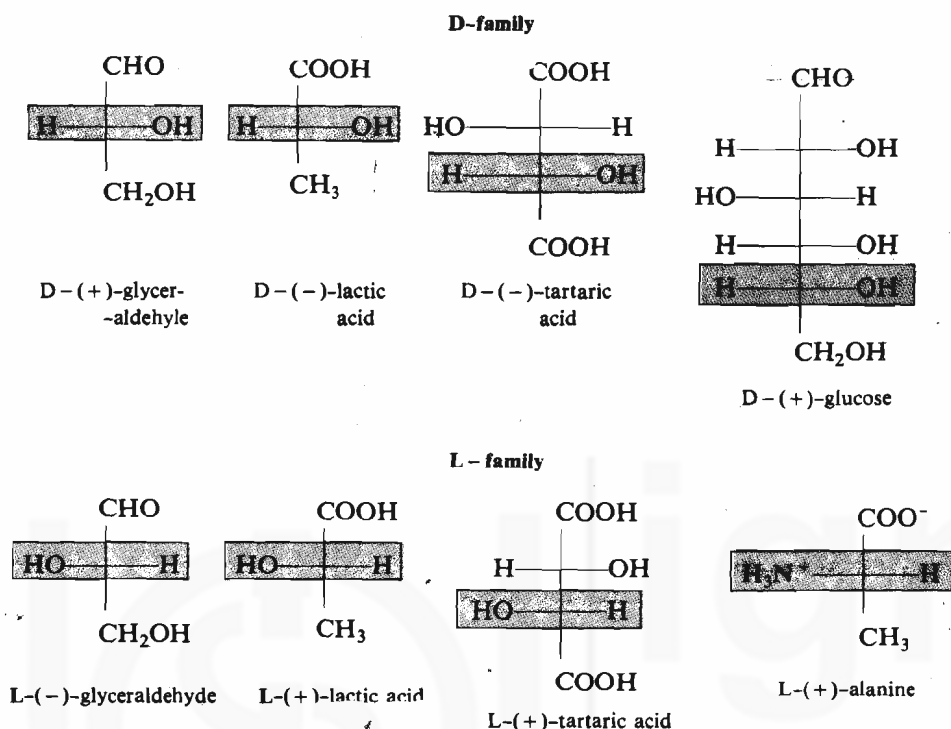

The D, L system is useful in specifying the configurations for carbohydrates and amino acids.

In the light of the fact that the configuration of a chiral centre in a compound is not changed unless at least one bond at the chiral centre is broken, chemists on the basis of the experimental evidences realised that the configurations of various optically active compounds can be related to each other even without knowing their absolute configurations. Thus, relative configurations of a large number of compounds could be determined.

The D, L system can be applied only when the main chain and the main substituents can be unambiguously chosen; hence, in some cases, it is not possible to assign the configuration by this system. For example, the molecules of the type

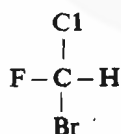

cannot be assigned configuration according to this system. Also there are cases when it is difficult to assign the configuration unambiguously to the molecules containing more than one chiral centre.

Thus, a more systematic way of denoting configurations was needed. The system that emerged is called the R, S convention and is based on the actual three-dimensional formula of the compound to be named. In this system, the configuration at the chiral centre is assigned by assigning the order of precedence to the groups attached to the chiral centre according to the specific set of rules. These rules have been already listed as Cahn-Ingold-Prelog priority rules in Unit 2. According to this system, the configuration of a given chiral centre can be assigned using the following steps:

1. Identify the four substituents attached to the carbon atom for which the configuration is to be assigned.
2. Arrange these substituents in the decreasing order of priority as  $1 > 2 > 3 > 4$  which is determined by Cahn-Ingold-Prelog rules.
3. View the molecule in such a way that the substituent of lowest priority is away from the observer.

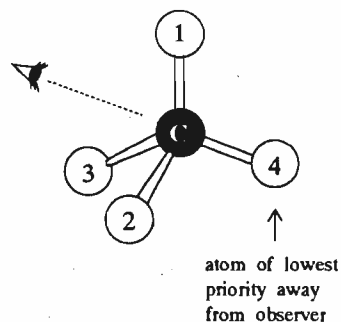

4. When the molecule is viewed in the way as suggested in step 3, the remaining substituents 1, 2 and 3 appear as spokes of a wheel, with the carbon atom at the centre of the wheel, as shown below.

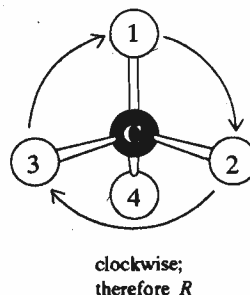

Now, trace a path starting from the substituent of highest priority to the substituent next in order of priority, i.e., from 1 to 2 to 3. If this path is in clockwise direction, as in the case of arrangement shown above, then the chiral centre is said to have the *R* configuration (*R* from *rectus*, a Latin word meaning: **right**).

If this path from 1 to 2 to 3 has an anticlockwise direction, then the chiral centre is said to have the *S* configuration (*S* from *sinister*, a Latin word meaning: **left**), i.e.

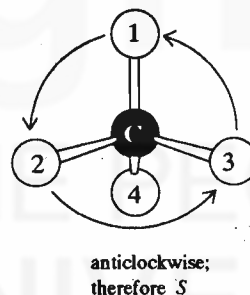

Since the assignment of *R* or *S* configuration to the molecule requires a specific orientation of the molecule in space, you should be able to write the three-dimensional orientation of a molecule from its Fischer projections and vice versa.

Let us now take the example of D-(+)-glyceraldehyde and see how the configuration at the chiral centre of a molecule can be assigned starting from its Fischer projection. The Fischer projection formula of D-(+)-glyceraldehyde can

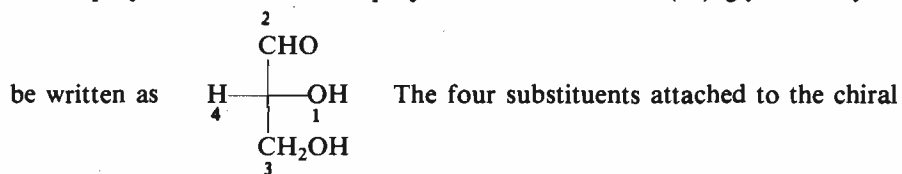

centre have the order of priorities as shown by the numbers  $1 > 2 > 3 > 4$ . Now, the molecule is to be viewed in such a way that the substituent of lowest priority, numbered 4, which is a hydrogen in this case, is away from the viewer. In other words, in the Fischer projection formula, this substituent should find a place at the bottom end. Thus, we have to transform the above Fischer projection into another Fischer projection as shown below:

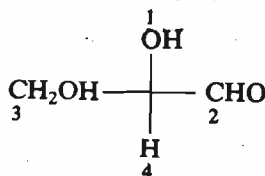

This new Fischer projection corresponds to the following perspective drawing.

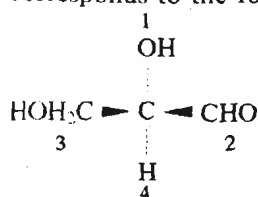

The molecule is then projected in such a way that H is at the back.

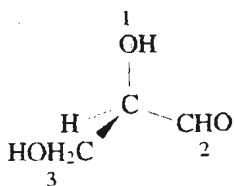

Use models to understand the transformations from perspective drawing to the assignment of configuration.

Then, by overlooking this H, path from 1 → 2 → 3 is traced as illustrated below.

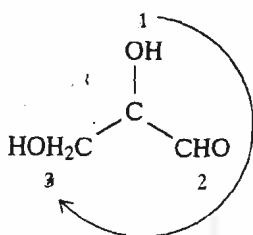

Since this path is clockwise, hence, D-(+)-glyceraldehyde is assigned *R* configuration.

There is another way which allows the assignment of configuration without having to visualise the three-dimensional structure of the molecule. Let us study it.

#### A simple way to assign *R* or *S* Configuration using Fischer Projections

It is a short cut method and requires that the Fischer projection is written in such a way that the substituent of lowest priority is at bottom. Then, this substituent is neglected and the configuration is assigned by tracing the path from 1 to 2 to 3, as stated before.

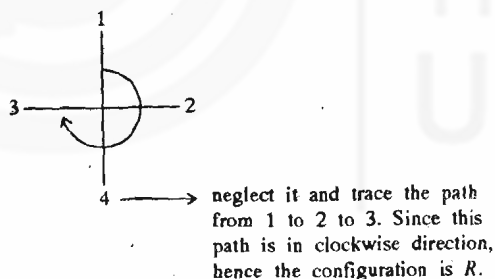

Similarly, in case of (+)-2-butanol,

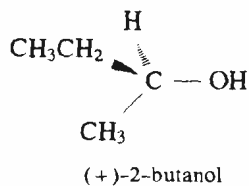

the order of priority of substituents is  $\text{OH} > \text{CH}_3\text{CH}_2 > \text{CH}_3 > \text{H}$ . If the molecule is viewed in such a way that the H is at the back, then the other substituents appear as shown below:

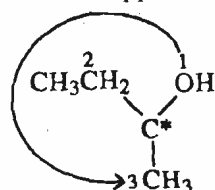

Now trace the path from 1 to 2 to 3 which is anticlockwise in this case. Hence, the configuration of the carbon atom marked by asterisk (\*) is *S*.

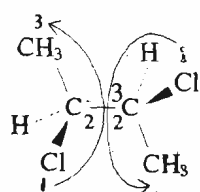

2,3-dichlorobutane

With the determination of absolute configuration of (+)-tartaric acid, the absolute configuration of its enantiomer (-)-tartaric acid was also established. The (-)-tartaric acid and (+)-glyceraldehyde were known to have the same relative configuration. Thus, the absolute configuration of (+)-glyceraldehyde was also established; and the configuration assigned earlier to (+)-glyceraldehyde arbitrarily was found to be correct.

In the compounds containing more than one chiral centre, the configuration is specified at each of these centres. For example, in case of 2,3-dichlorobutane, the

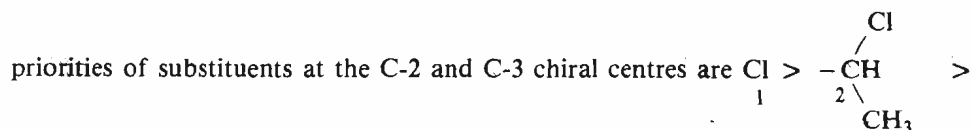

$\text{CH}_3 > \text{H}$ . Focusing our attention on C-2 carbon, the path from substituents 1 to 2 to 3 has anticlockwise direction; hence, it has *S* configuration. Similarly, at C-3 carbon also, the path from 1 to 2 to 3 is in anticlockwise direction. Hence, it also has *S* configuration. Thus, this isomer of 2,3-dichlorobutane is named as, (2*S*, 3*S*)-2,3-dichlorobutane.

It is not difficult to decide whether a molecule has *R* or *S* configuration if the actual arrangement of the groups about the chiral centre is known. But, how to determine the actual arrangement of the groups? Until 1951, the absolute configuration of any optically active compound was not known. In 1951, Bijvoet determined the absolute configuration of (+)-tartaric acid using a sophisticated modification of X-ray diffraction called **anomalous dispersion**. Then, the absolute configurations of all other compounds whose configurations had been related to (+)-tartaric acid were also revealed.

To determine the configuration, one must have a pure sample of the compound. But this is not usually the case and most often in chemical reactions one gets a mixture of enantiomers. In the next section, we will study in detail about these mixtures and their separation into enantiomers. Before that answer the following SAQ.

**SAQ 2**

Assign the configuration as *R* or *S* to each of the following compounds:

(a)

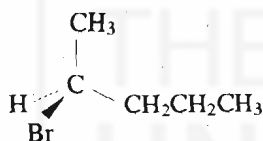

.....  
 .....

(b)

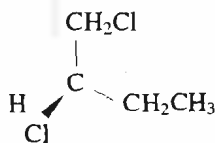

.....  
 .....

(c)

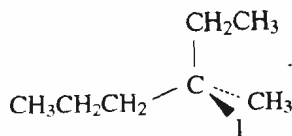

.....  
 .....

(d)

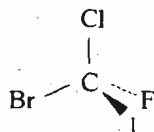

.....  
 .....

### 3.4 RACEMIC MIXTURES AND THEIR RESOLUTION

A mixture containing equal amount of each enantiomer of a compound is called a **racemic mixture** or a **racemic modification** or a **racemate**. A racemic mixture is indicated by the ( $\pm$ )-sign or just by the term racemic prefixed to the name of the compound.

The physical properties of a racemic mixture are different from those of the pure enantiomers. For example, the melting point of the either enantiomer of *Z*-hydroxypropanoic acid (lactic acid) is 326 K but the racemic 2-hydroxypropanoic acid (lactic acid) has a melting point of 291 K. Also, since a racemic mixture contains equal amounts of enantiomers, optical rotation of one enantiomer is cancelled by an equal and opposite rotation of the other enantiomer. Hence, a racemic mixture is **optically inactive** although its constituents are **optically active**.

A racemic mixture can be obtained from a pure enantiomer by a process called **racemisation**. It can also be obtained by simply mixing two enantiomers in equal amounts. Racemic mixtures may also result from chemical reactions. One such kind of reactions is the *nucleophilic substitution reaction*. You will study about these reactions in detail in the Organic Reaction Mechanism course. But to give you an idea about how a racemic mixture results from them, one such reaction is illustrated in the box.

A **substitution reaction** can be defined as the reaction in which one group is substituted by another group. For example, in the reaction below,

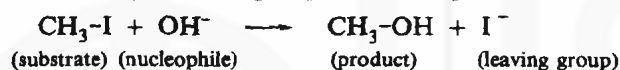

the iodide group is substituted by the hydroxide group. When the incoming group ( $\text{OH}^-$  group in this case) is a **nucleophile**, (means seeking a *nucleus*; obviously an electron rich species), then the reaction is called **nucleophilic substitution reaction**.

The nucleophilic substitution reactions can be **unimolecular** or **bimolecular**, depending upon the number of molecules involved in the rate-determining step of the reaction. When the rate-determining step involves a single molecule, the reaction is called a *unimolecular substitution reaction* and is denoted as  $\text{S}_{\text{N}}1$ . The  $\text{S}_{\text{N}}1$  reactions involve a positively charged carbon atom as an intermediate which is called a **carbocation**. Such a carbocation is shown below.

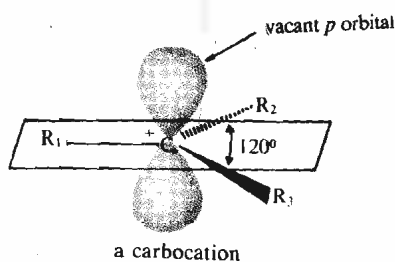

This carbocation being planar, can be attacked by the incoming group or nucleophile from either side leading to the formation of both the enantiomers. If the attack is equally favourable from both the sides, then the enantiomers

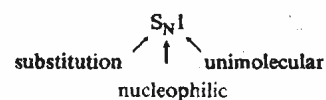
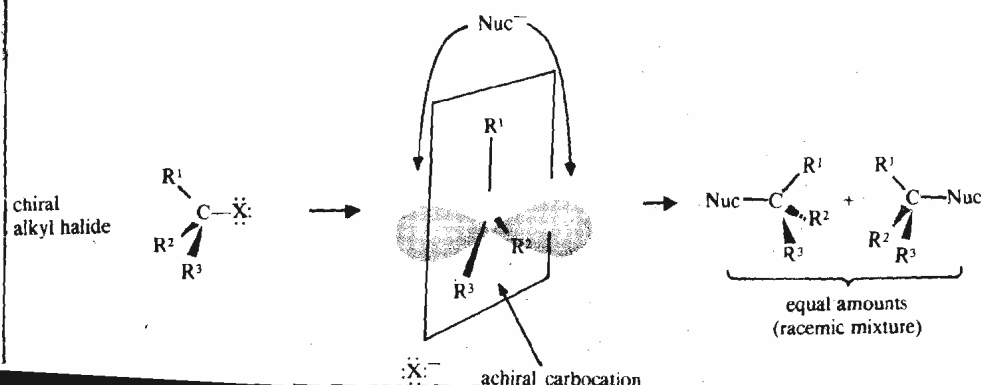

are formed in equal amounts and the product obtained is a racemic mixture.

The stereochemistry of *bimolecular substitution reactions* will be discussed in Sec. 3.6.

Once a racemic mixture is obtained, the next step is to separate this mixture into its pure components. The separation of a racemic mixture into the enantiomers is called **resolution**. The first resolution was that of tartaric acid by Pasteur in 1848. Tartaric acid was obtained as a by-product of wine making and was found almost always as its dextrorotatory  $2R,3R$  stereoisomer. Occasionally, an optically inactive sample of tartaric acid was obtained.

One day Pasteur was viewing the crystals of sodium ammonium double salts of (+)-tartaric acid and inactive tartaric acid. He found that the crystals of the double salt of (+)-tartaric acid were hemihedral, (see Fig. 3.3a). But the crystals of the double salt of inactive acid were not the crystals of just one type, but a mixture of two types and these two types of crystals were mirror images of each other [see Fig. 3.3(a) and (b)]. He separated the two types of crystals with a pair of tweezers. These two types of crystals showed *equal and opposite optical rotation*. Thus, the inactive sample of tartaric acid was actually a **racemic mixture**. Pasteur had thus performed the first resolution by human hands! Before this the levorotatory form of tartaric acid was not known. It is now known that the double salt of racemic tartaric acid forms two types of crystals, as shown in Fig. 3.3(a) and (b), only at temperatures below 299 K. Had the temperature of Pasteur's laboratory been above this temperature, he would have obtained the crystals of the type shown in Fig. 3.3(c) and he would not have made this discovery.

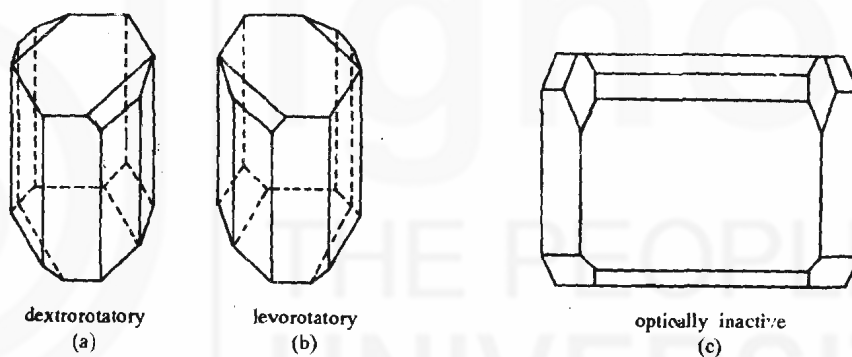

**Fig. 3.3 :** a) Dextrorotatory hemihedral crystals of sodium ammonium tartarate. b) Levorotatory crystals of sodium ammonium tartarate. c) Holohedral crystals of racemic sodium ammonium tartarate that crystallises at a higher temperature.

Resolution by ordinary physical methods like crystallisation, distillation, chromatography etc. is not possible because the physical properties of the two components, except the direction of rotation, are identical. Almost all methods of resolution make use of the fact that only under the influence of another chiral reagent, the enantiomers can be made to behave differently. Hence, the enantiomeric mixture is treated with a chiral substance to convert it into a mixture of diastereomers. Since the diastereomers have different physical properties, they can be separated using physical methods. The enantiomers are then regenerated from each diastereomer. The general scheme for resolution involving the formation of diastereomers is depicted in Fig. 3.4. The advantage of acid-base properties is also taken in obtaining the diastereomers. For example, if we want to resolve an acid A which is present as a mixture of the enantiomers (+)-A and (-)-A as shown in Fig. 3.4 (a); then we choose either of the enantiomers of base B, which is, say, (+)-B in this case. When the base (+)-B is added to the racemic mixture of acid A, diastereomers of the type (+)-A(+)-B and (-)-A(+)-B, as shown in Fig. 3.4(b), are obtained. These diastereomers can then be separated using physical methods, [see Fig. 3.4(c)].

The individual enantiomers of acid A are then regenerated from each of the above diastereomers by treatment with a mineral acid, Fig. 3.4 (d). Similarly, we can resolve a racemic mixture of a base using a chiral acid. The chiral reagents which are used for resolving a racemic mixture are called **resolving agents**. A number of



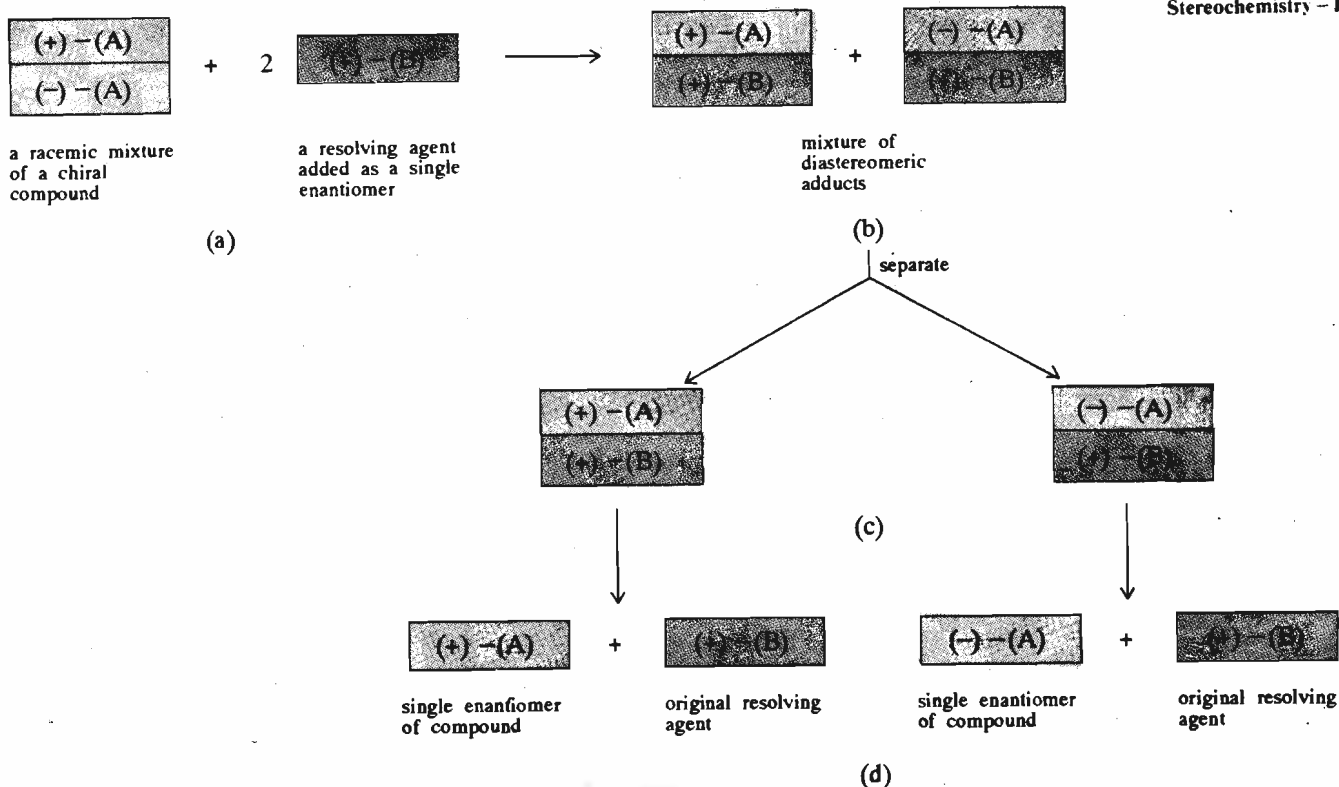
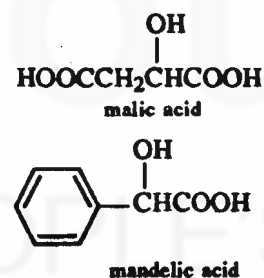
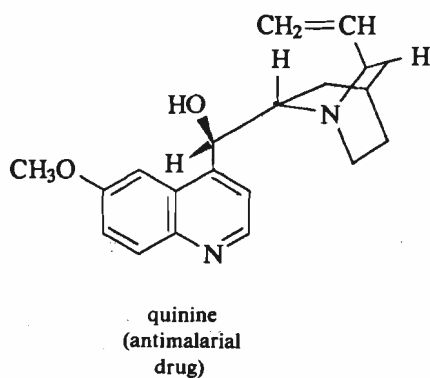
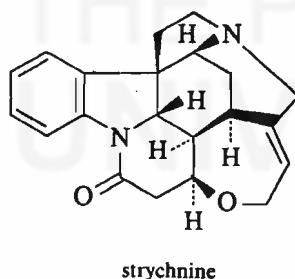
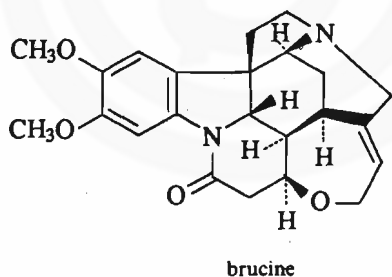

Fig. 3  
c) Diastereomers separated. d) Enantiomers regenerated from diastereomers.

resolving agents are available, many of them are naturally occurring acids and bases. For example, chiral bases such as brucine, strychnine and quinine are used for resolution. On the other hand, chiral acids such as (+)-tartaric acid, (-)-malic acid and (-)-mandelic acid are used for resolution of racemic bases. Analogous methods for resolution of compounds containing other functional groups have also been developed.



Chromatographic methods for resolution using chiral adsorbents have also been developed. In such methods, one of the enantiomers gets adsorbed on the chiral

adsorbent more strongly than the other leading to their partial separation. The drawback with chromatographic resolution is that it is not quantitative.

As pointed out earlier, the resolution is effective only under a chiral influence. Such an influence can also be exerted using enzymes. The enzymes are highly selective with regard to stereochemistry of the compounds with which they interact. Hence, they can perform the resolution by metabolising only one enantiomer and rejecting the other. For example, the racemic ammonium tartarate when fermented using yeast or a mold (*Penicillium glaucum*), showed that the dextrorotatory isomer is consumed faster by the mold leaving behind the pure levorotatory isomer. A disadvantage of the resolutions of this type is that the more reactive enantiomer is usually not available and we get **only one** enantiomer at the end of the resolution.

Pure enantiomers can also be obtained using synthetic methods, without the necessity of resolution. In the next section, you will study about these methods in detail.

### 3.5 ASYMMETRIC SYNTHESIS

It is a general principle that *the optically inactive starting materials in a reaction yield optically inactive products*. To obtain an optically active product from an optically inactive starting material, it is necessary that in some way the reaction is so influenced that only one of the two enantiomers is selectively obtained. Such a synthesis is called **asymmetric synthesis** or **stereoselective synthesis**.

An asymmetric synthesis can be of two types: **partial asymmetric synthesis** and **absolute asymmetric synthesis**. In partial asymmetric synthesis, an optically active substrate or an optically active reagent is employed. Partial asymmetric synthesis can also be affected by using an optically active solvent or an optically active catalyst. On the other hand, an absolute asymmetric synthesis is the one which **does not** involve intermediate use of any optically active compound but is affected by 'physical reagents' such as **circularly polarised light**.

The first asymmetric synthesis was carried out by Marckwald in 1904 who obtained optically active (-)-2-methylbutanoic acid starting from ethylmethylmalonic acid. The scheme of reactions is shown below.

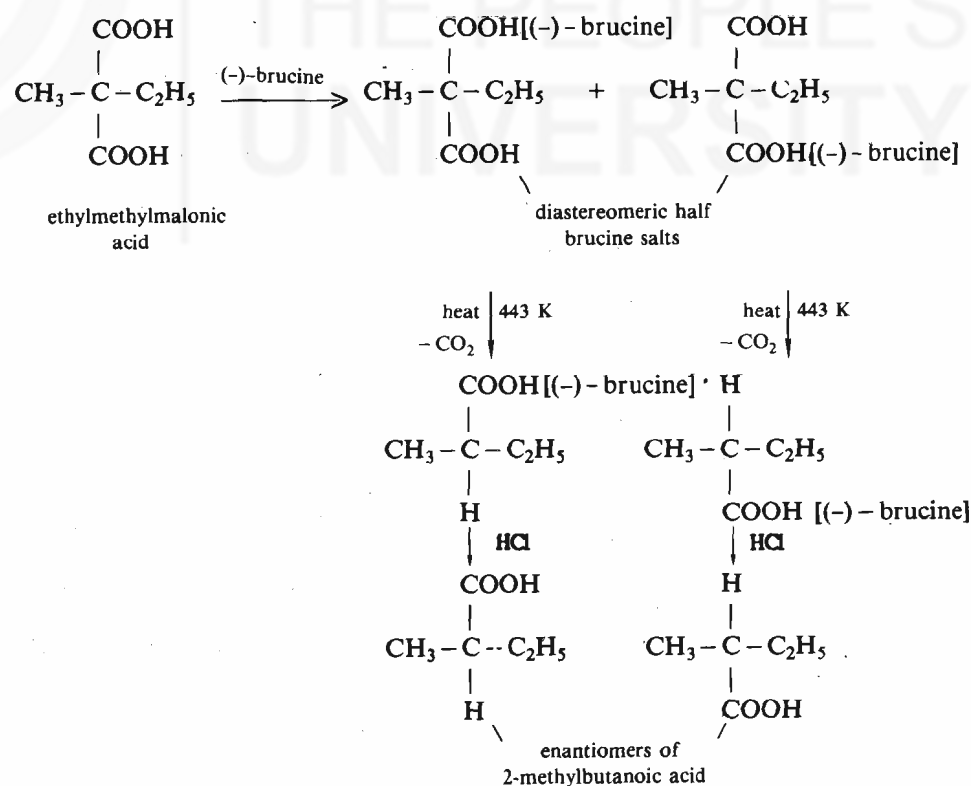

Since the two half brucine salts are diastereomeric, they yield the enantiomers of 2-methylbutanoic acid in different amounts, with the *levo* isomer predominating.

An example of partial asymmetric synthesis using optically active substrate is given below. Here, the attacking  $\text{CN}^-$  ion can approach the carbonyl carbon from two directions as shown, leading to the formation of enantiomeric products.

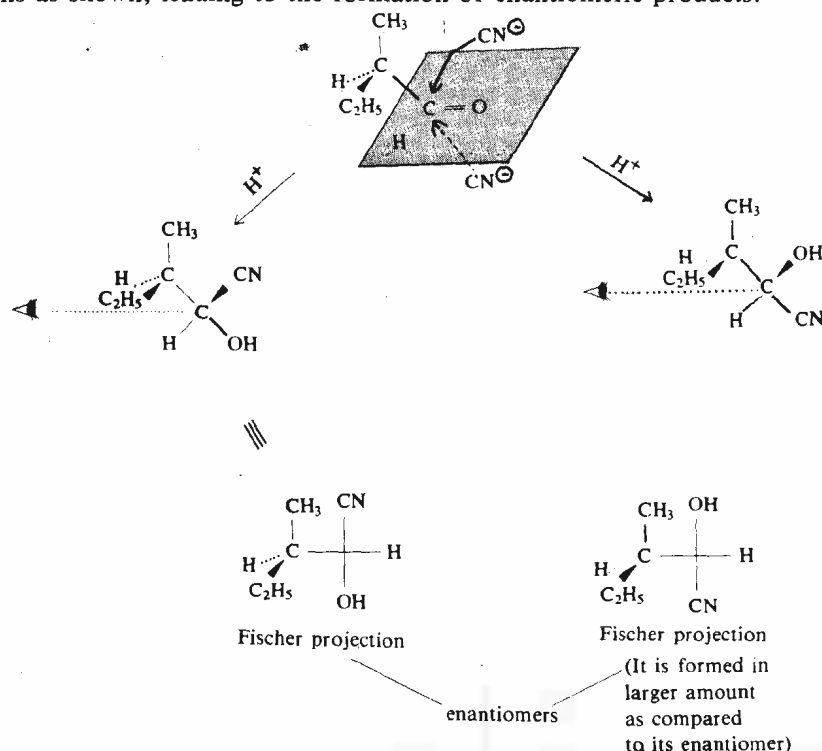

Use models to understand this example of partial asymmetric synthesis.

But, the approach of the reagent ( $\text{CN}^-$  anion) from the side of lesser steric hindrance (crowding) is preferred (i.e., from the downward direction) and we get the corresponding enantiomer in larger amount.

Many reactions of this type are known and in some of these reactions, the extent of stereoselectivity approaches 100%.

It was pointed out earlier that circularly polarised light can be used to achieve absolute asymmetric synthesis. The plane-polarised light is in fact a mixture of two forms of light which are called, respectively, *left-* and *right-* circularly polarised light. The electric fields of these light forms propagate through space as *left-* and *right-* handed helices as shown below in Fig. 3.5. You can see in the figure that

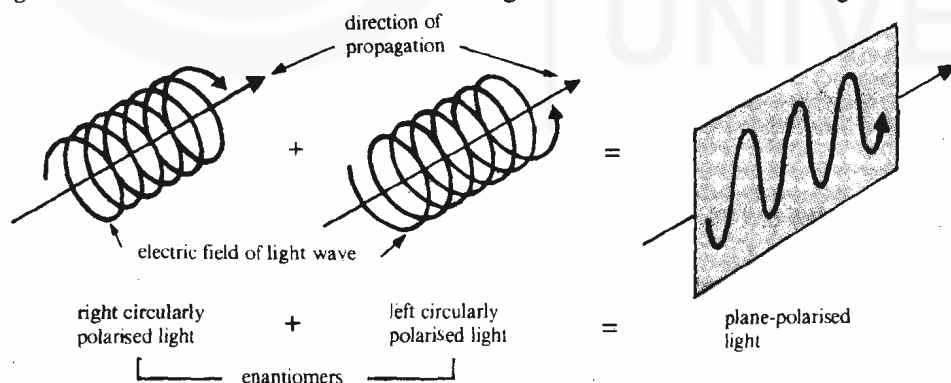

The origin of chiral biological molecules is attributed to the effect of circularly polarised light in the early phases of evolution of life.

Fig. 3.5 : The electric fields of *right-* and *left-* circularly polarised light which add vectorially to give plane-polarised light.

the two helices are enantiomeric. The vector addition of these two forms leads to plane-polarised light. Such *right-*circularly polarised light was used in the addition of bromine to 2,4,6-trinitrostilbene to yield the dextrorotatory product.

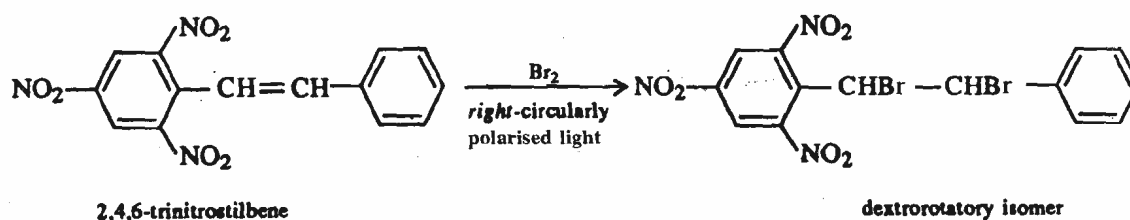

In this section, you have studied about how to obtain optically active compounds starting from optically inactive compounds. In the next section, you will study about the transformation of one enantiomer into another enantiomer which in fact involves the inversion of configuration. This phenomenon was first discovered by Walden and is known as *Walden Inversion*. Let us now study this phenomenon.

### 3.6 WALDEN INVERSION

Walden, in 1893, reported the following cycle of transformations.

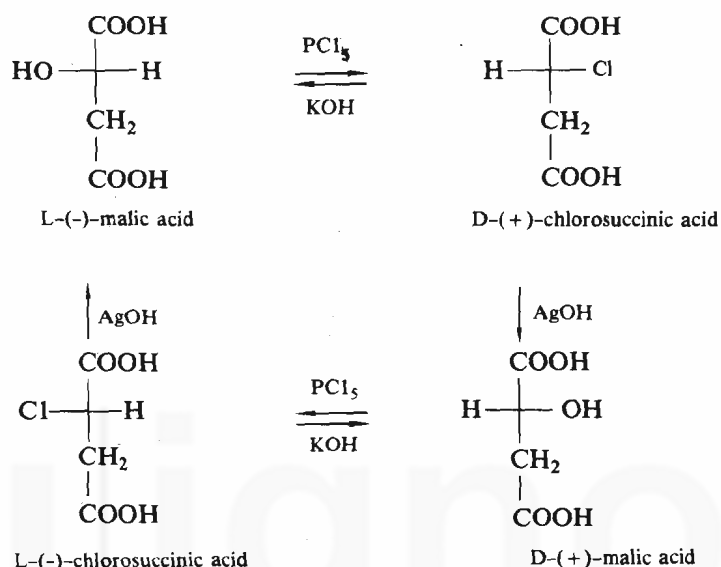

You can see that L-(-)-malic acid was converted to its enantiomer, D-(+)-malic acid in a two stage process. Similarly, L-(-)-chlorosuccinic acid was converted into its enantiomeric D-(+)-chlorosuccinic acid. Since an enantiomer is obtained, configuration at the chiral centre **must** have changed in **one** out of the **two** reaction stages. The step in which the inversion of configuration takes place is said to have undergone the **Walden inversion**. In some cases, the Walden inversion has been reported to be 100%. Note that the reactions in which the inversion is not complete, lead to racemisation.

The Walden inversion is a rule for bimolecular nucleophilic substitution reactions. The term **bimolecular** refers to the fact that **two** species undergo bonding changes in the transition state of the reaction. These reactions are represented in short as  $S_N2$  reactions. The stereochemistry of one such reaction is shown in the box.

substitution  $S_N2$  nucleophilic bimolecular

If in the  $S_N2$  reaction, the attack of the nucleophile is from one side and the leaving group leaves from the opposite side simultaneously, as is shown in the transition state in the following example, then, such reactions proceed with the inversion of configuration. And, if the species that undergoes inversion has the same substituents on it before and after the inversion, the product obtained is the enantiomer of the starting compound, as was the case studied by Walden.

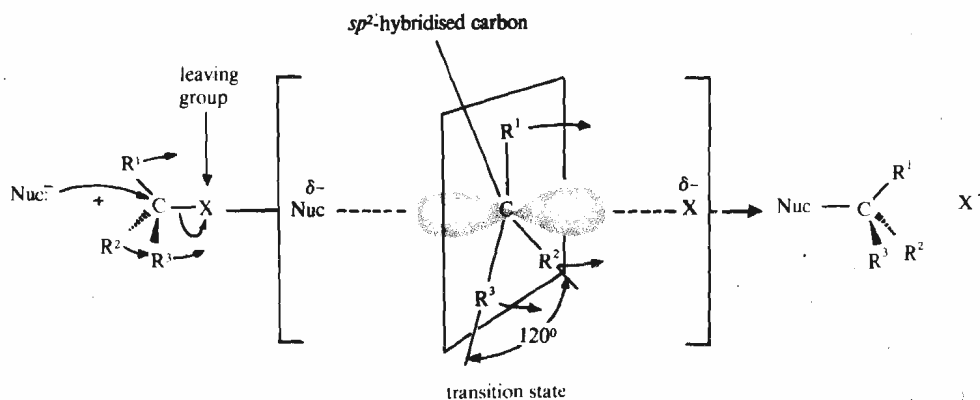

Thus, we can conclude that  $S_N1$  type of reactions involve racemisation whereas  $S_N2$  type of reactions are accompanied by inversion of configuration.

Till now you were studying about the configurational isomers in which the configuration at the chiral centre cannot be changed without breaking the bonds. Let us next study about those stereoisomers which are interconvertible without breaking the bonds between the atoms.

### 3.7 CONFORMATIONAL ISOMERS AND THEIR REPRESENTATION

The various spatial arrangements obtained by rotation about the single bonds are called **conformations**. Among the different conformations of a molecule, the stable ones are known as **conformers** or **conformational isomers**. The simplest molecule which shows these conformations is ethane. Before starting the study of conformations of various molecules, let us learn how to represent these conformations which are again three-dimensional spatial arrangements of a molecule, in two-dimensions. You have already learnt about the Fischer projections for representing the configuration of a compound. Two types of representations, namely, *Newman projections* and *Sawhorse projections* are used to show the conformations. We will first study the Newman projections.

#### Newman Projections

For writing the Newman projections of a molecule, it is viewed along the carbon-carbon bond as shown for ethane in Fig. 3.6(a). Here, the ethane molecule is shown in Wedge and dash drawing. In drawing the Newman projection, the carbon

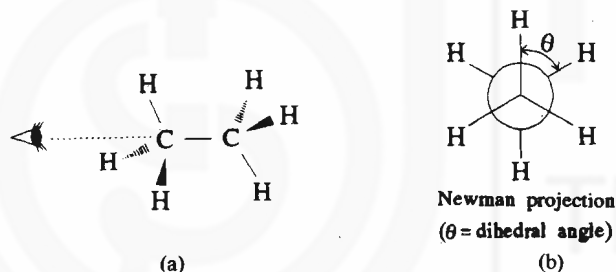

Fig. 3.6 : a) Wedge and dash drawing of ethane; solid wedges show the bonds above the plane of paper and dash lines represent the bonds behind plane of the paper whereas the ordinary lines represent the bonds in plane of the paper. b) Newman projections of ethane.

atom nearer to the observer is represented by a point and the three groups attached to it are shown by three lines emerging from this point [Fig. 3.6(b)]. The rear carbon is shown by a circle and the three substituents attached to this carbon are shown by three lines emerging from the edge of the circle. The angle,  $\theta$ , between the  $H-C-C$  plane and the  $C-C-H$  plane of an  $H-C-C-H$  unit is called the **dihedral angle**.

Let us now understand how to write the sawhorse projections.

#### Sawhorse Projections

In this representation, the carbon-carbon single bond is represented by a line and is oriented diagonally backward, i.e., the left hand carbon projects towards the viewer and the right-hand carbon projects away from the viewer. This is illustrated in sawhorse projections for ethane in Fig. 3.7. Analogous to the Newman projections, here also the substituents on each carbon are shown by lines.

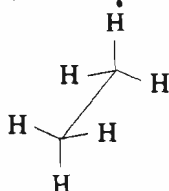

Fig. 3.7 : Sawhorse representation of ethane.

You are advised to use the models in understanding these representations.

Remember that the four substituents attached to the carbon atoms in ethane are arranged in tetrahedral fashion.

We now know how to represent a molecule in Newman or sawhorse projections. These projection formulas are useful in studying the conformations of simple molecules. Let us now study the conformations of ethane.

### 3.8 CONFORMATIONS OF ETHANE

A number of different conformations are possible for ethane molecule depending upon the value of the dihedral angle,  $\theta$ . Fig. 3.8 shows the variation of potential energy for various conformations of ethane.

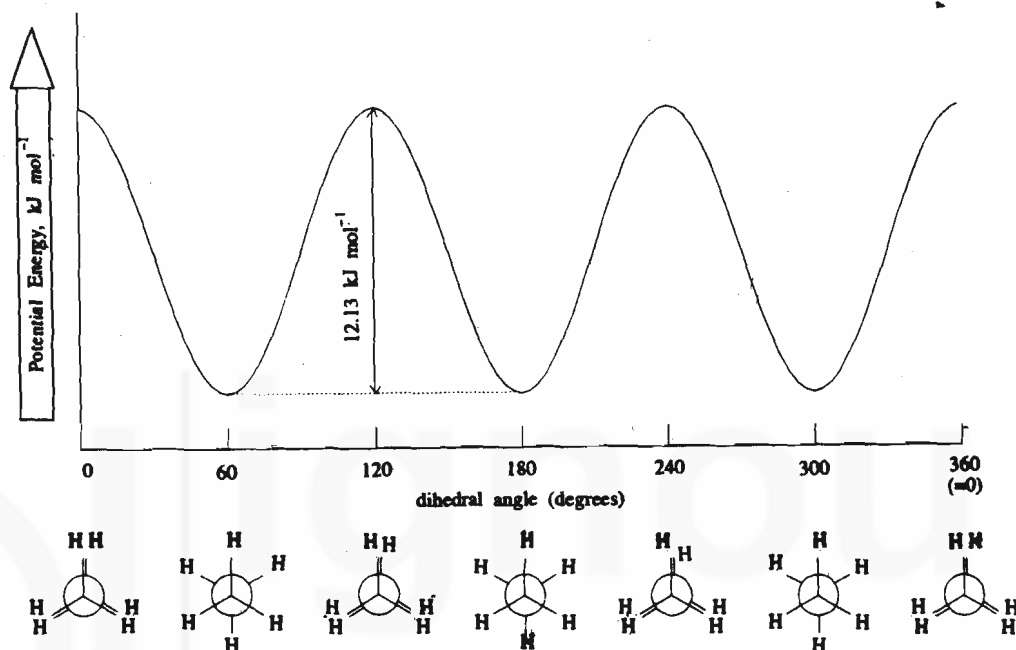

#### Activity

Make a model of ethane molecule in which one C-H bond on each carbon atom has a different colour. Rotate along the C-C single bond and try to make eclipsed and staggered conformations. Convince yourself that they have the dihedral angles as  $0^\circ$  and  $60^\circ$ , respectively.

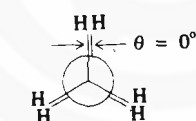

eclipsed conformation of ethane

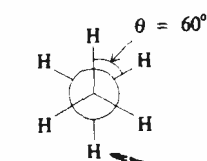

staggered conformation of ethane

While comparing the stability of various conformations, remember that the conformation having the least potential energy is the most stable conformation. Thus, ethane has one conformer which is the staggered conformation.

The analysis of molecular conformations and their relative energies is called **conformational analysis**.

Fig. 3.8 : Variation of potential energy with dihedral angle. Here, to make it easy to visualise the dihedral angle, the two hydrogens on the two carbons are shown in the different colour

When the dihedral angle is  $0^\circ$ , then the hydrogens on the two carbon atoms are parallel and the conformation is known as **eclipsed conformation**. The other limiting possibility is when the dihedral angle is  $60^\circ$ ; this is called **staggered conformation**. Fig. 3.8 shows that there is an energy difference of  $12.13 \text{ kJ mol}^{-1}$  between the eclipsed and staggered conformations, with the staggered conformation having the lower energy. This can be explained in terms of the maximum separation of bonded electron pairs in the staggered conformation which leads to minimum repulsion between them. On the other hand, in the eclipsed conformation, the C-H bonds are closer and hence, there is a repulsion between the electrons forming these bonds. Thus, the staggered conformation is more stable than the eclipsed conformation. The energy difference of  $12.13 \text{ kJ mol}^{-1}$  between these two conformations is very small as compared to the kinetic energy of the molecule due to molecular motions and even at low temperatures a molecule can pass from one staggered conformation to another staggered conformation (although in between it has to pass through an eclipsed conformation) at the rate of about  $10^{11}$  times per second! Thus, the interconversion of conformations is very rapid; nevertheless it is not strictly 'free' in the sense that there is an energy barrier of  $12.13 \text{ kJ mol}^{-1}$  to be overcome. Hence, the ethane molecule spends most of its time in its staggered forms, passing only transiently through its eclipsed forms. Before you proceed to study the conformations of another alkane, namely butane, answer the following SAQ.

#### SAQ 3

Draw the eclipsed and staggered conformations of ethane in sawhorse representation.

### 3.9 CONFORMATIONS OF BUTANE

The sawhorse and Newman projections of butane are represented below.

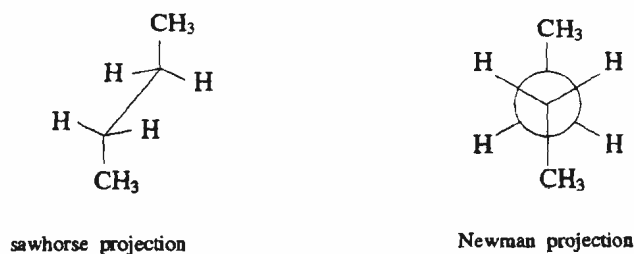

Similar to the case of ethane, various conformations of butane are possible due to rotation of the C-C bond formed by the carbon atoms numbered as 2 and 3.

Fig. 3.9 shows the potential energy variation for various conformations of butane.

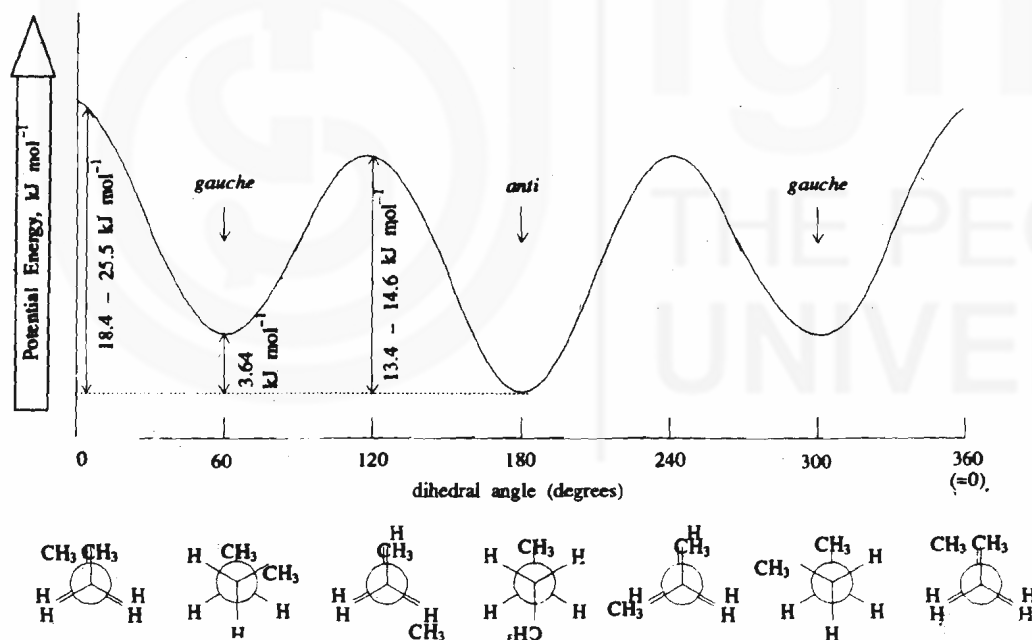

Fig. 3.9 : Potential energy diagram for the conformations of butane.

As the figure shows, when the dihedral angle is zero, the conformation is called **eclipsed conformation**. As the dihedral angle increases to  $60^\circ$ , we get another conformation which is called **gauche or skew conformation**. Further rotation of the  $C_2-C_3$  bond yields another **eclipsed conformation** when the dihedral angle is  $120^\circ$ . Note that in this conformation  $CH_3$  and  $H$  are eclipsed whereas in the earlier eclipsed conformation two methyl groups were eclipsed. Hence, this eclipsed conformation is at a little lower energy level than the earlier eclipsed conformation. When the two methyl groups are maximum apart, i.e., when the dihedral angle is  $180^\circ$ , then the conformation is known as **anti conformation**. Note that this is the most stable conformation of butane because it has the lowest energy value. On further rotation, another set of **eclipsed and gauche** conformations result. The difference in energy between the **anti and gauche** conformations is about  $3.64 \text{ kJ mol}^{-1}$ . At room temperature, butane is a mixture of 72% anti and 28%

#### Activity

Make a model of butane. Rotate along the  $C_2-C_3$  single bond. Try to make various conformations shown in Fig. 3.9 and study their dihedral angles.

Butane has two conformers; namely, *anti* and *gauche* conformations. The *anti* conformer is more stable as compared to the *gauche*, as shown in Fig. 3.9.

Hassel and Barton received Nobel Prize in Chemistry in 1969 for their contributions in the field of conformational analysis.

gauche conformations. Similar to ethane, in this case also, the interconversion of these conformations is rapid and if one wants to separate them, one has to make the interconversion slow by working at very low temperatures of about 43 K.

The study of conformations or **conformational analysis** is helpful in explaining the specificity of reactions; particularly, the reactions observed in living systems where such a specificity is exhibited by virtue of the particular conformations of the compounds.

At this stage, you can check your understanding about conformations of simple straight chain alkanes by answering the following SAQ.

**SAQ 4**

- a) Write sawhorse projections for the two gauche conformations of butane.  
 .....  
 .....
- b) What is the value of dihedral angle in these conformations?  
 .....  
 .....
- c) What relationship do these two gauche conformations have with each other?  
 .....  
 .....

**3.10 CONFORMATIONS OF CYCLIC SYSTEMS**

During the nineteenth century, it was believed (erroneously, as we shall see in the subsequent discussion) that the cycloalkanes are planar. According to the German chemist Baeyer, the internal bond angles for cycloalkanes should be the same as those of the corresponding regular polygons. This is shown below.

The bond angle in a polygon having n sides is given by  $\left(\frac{2n - 4}{n}\right) \times 90^\circ$ . For example, in cyclopropane having n=3, the bond angle =  $\left(\frac{2 \times 3 - 4}{3}\right) \times 90^\circ = 60^\circ$

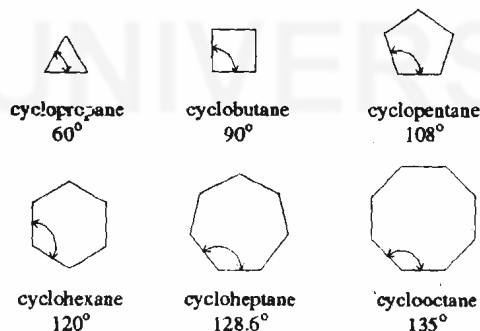

In order to explain the fact that the cyclic compounds having rings containing fewer than five or more than six carbon atoms were less abundant in nature, he suggested that the stability of such compounds could be related to the tetrahedral bond angle of 109.5°. The deviation from this angle could cause a strain in the molecule leading to its decreased stability. This type of instability is called **angle strain**. According to this explanation, as the deviation from the tetrahedral value decreases, the stability should increase. Thus, the stability should increase from cyclopropane → cyclobutane → cyclopentane. As the deviation in angle from the tetrahedral angle of 109.5° is minimum in case of cyclopentane, Baeyer predicted it to be most stable. Cyclohexane and higher cycloalkanes according to him would be less stable than cyclopentane because the angles of larger polygons deviate more and more from the ideal tetrahedral angle.

The experimental values of heat of combustion per methylene group showed that the energies for the first three cycloalkanes are in the following order:



cyclopropane > cyclobutane > cyclopentane. This order is consistent with the predictions of the Baeyer's strain theory. But in case of cyclohexane, the heat of combustion is less indicating its greater stability. Further increase in the ring size does not affect the heat of combustion much, indicating a constant value of about 652.7 kJ mol<sup>-1</sup> per methylene group in contradiction to the prediction of Baeyer Strain Theory that with the increase in the ring size, angle strain must increase.

Baeyer's theory failed because of the assumption that the cycloalkanes are planar. Of course, cyclopropane has to be planar because three carbons must lie in a single plane. But other larger cycloalkanes are **not planar and are puckered**. Puckering of rings relieves the angle strain. You will study about this in detail in case of cyclohexane in the following discussion.

### 3.10.1 Conformations of Cyclohexane

If you make a model of cyclohexane containing 6 sp<sup>3</sup> hybrid carbon atoms forming a regular hexagon, you will realise that in this molecule, in addition to the angle strain, the hydrogens on the adjacent carbon atoms have the eclipsed arrangement as depicted in Fig. 3.10.

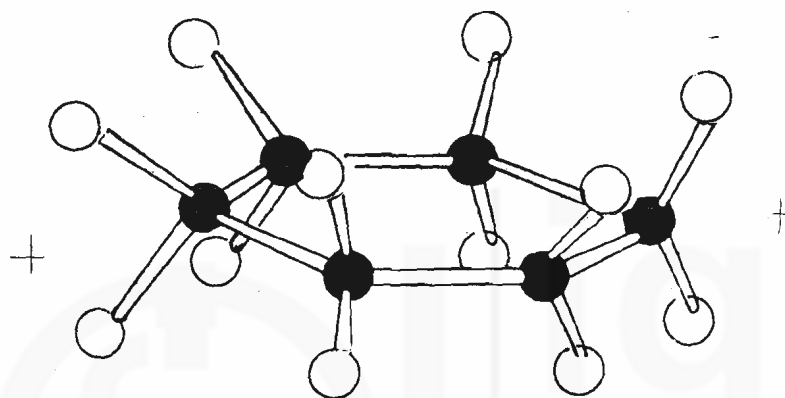

Fig. 3.10 : Strained planar conformation of cyclohexane showing eclipsed hydrogens.

Sachse in 1890 pointed out that two nonplanar models for cyclohexane are possible which are free from angle strain. These are called **chair** and **boat** conformations and are shown in Fig. 3.11.

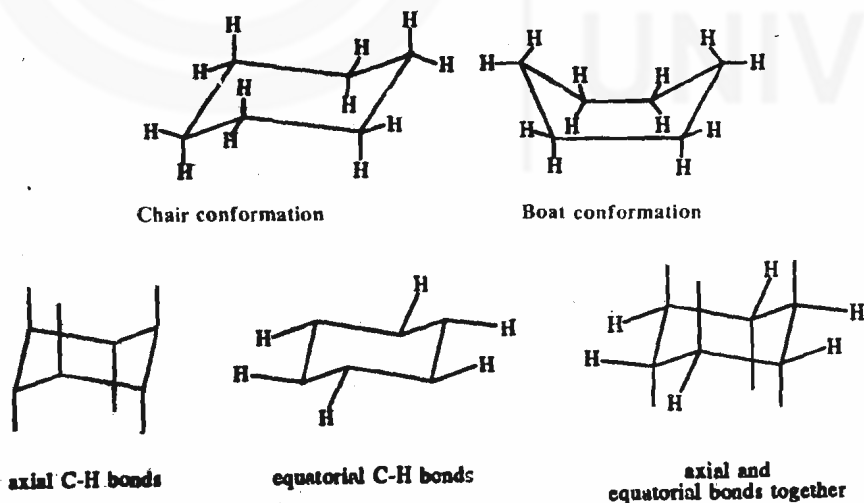
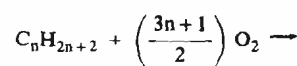

Fig. 3.11 : Chair and Boat conformation of cyclohexane.

There are two types of hydrogens in the chair form of cyclohexane. The six hydrogens which are above and below the plane of the carbon ring are called **axial** hydrogens. Note that the axial bonds are alternately directed up and down on the adjacent carbon atoms. The second set of hydrogens is called **equatorial** hydrogens and are located approximately along the equator of the molecule. Given below are the steps to enable you to represent the axial and equatorial bonds correctly on the chair conformation of cyclohexane.

General equation for combustion of alkanes is



alkane            oxygen

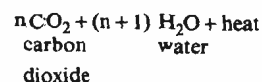

The heat released on complete combustion of one mole of a substance is called its heat of combustion.

The heat of combustion data is useful in determining the relative energies of various molecules.

Higher the heat of combustion per methylene group, lower will be the stability.

Steps

- 1) Draw the chair conformation of cyclohexane: as,

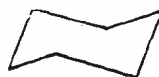

- 2) Draw one axial bond as shown below,

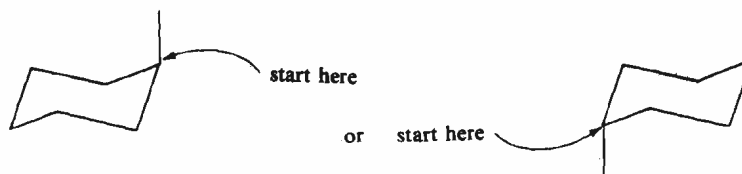

and then draw axial bonds alternately up and down as represented below.

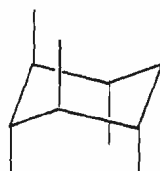

all axial bonds are parallel to each other

- 3) Draw equatorial bonds keeping in mind the tetrahedral arrangement at the carbon atoms. Draw an equatorial bond at C-1 in such a way that it is parallel to the carbon-carbon bond between C-2 and C-3 and then complete the other equatorial bonds as shown below.

Activity

Practice drawing cyclohexane chairs oriented in either direction.

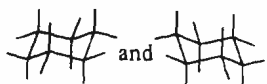

Chair cyclohexane drawings resemble sawhorse projections of staggered conformations of alkanes.

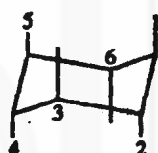

Place equatorial bond at C-1 so that it is parallel to the bonds between C-2 and C-3, and between C-5 and C-6.



You can notice the sawhorse representation of the staggered bonds in the above chair conformation. This staggered nature of bonds can also be visualised in the Newman projections of the chair conformation of cyclohexane as shown below:

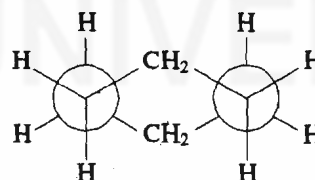

staggered arrangement of bonds in chair conformation of cyclohexane

However, a similar representation of the boat form of cyclohexane shows the eclipsed bonds.

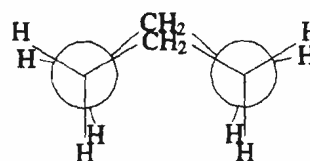

eclipsed bonds in boat conformation give it torsional strain

van der Waals repulsions

flagpole hydrogens

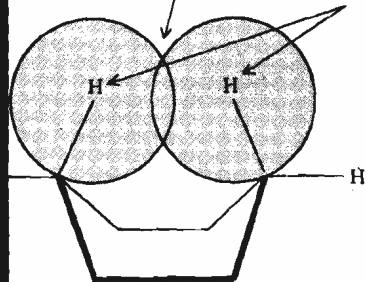

If the distance between two non-bonded atoms is less than the sum of their van der Waal's radii, there is repulsive interaction between the two-atoms. This is known as *van der Waal's repulsions*.

Further, in the boat conformation the two hydrogens, at the bow and stern of the boat, called **flagpole hydrogens** are 183 pm apart. This distance is significantly lesser than the sum of their van der Waal's radii (240 pm) and it results in a repulsion between them. These van der Waal's repulsions increase the energy of the boat form as compared to the chair form by about 27 kJ mol<sup>-1</sup>.

A portion of the strain due to the flagpole interactions in the boat conformation is relieved in the **twist boat** (or **skew boat**) conformation, which is obtained by slightly twisting the boat conformation as shown below:

The conversion of a boat into a twist-boat cyclohexane

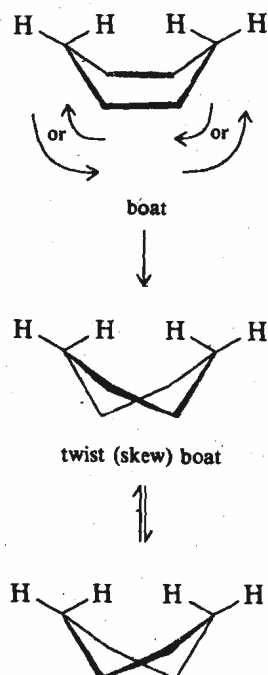

The twist boat form is more stable than the boat conformation but is less stable than the chair conformation by about  $2.51 \text{ kJ mol}^{-1}$ . As the chair conformation is the most stable form, most of the molecules of cyclohexane exist in the chair form. The available experimental data indicate that no more than one or two molecules per thousand exist in the skewboat conformation.

A chair conformation is also convertible into another chair conformation by the process known as **ring flipping**. This interconversion, as shown in Fig. 3.12, occurs via the intermediate half-chair and skew-boat conformations. The energy profile for such an interconversion is shown in Fig. 3.12. The ring flipping requires an energy of  $45.18 \text{ kJ mol}^{-1}$  and even at room temperature, this interconversion is very fast.

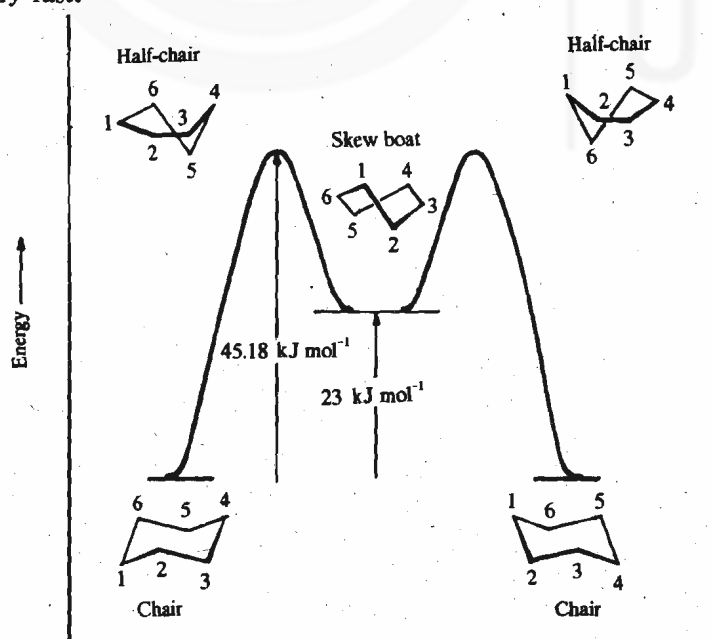

Fig. 3.12 : Energy profile associated with ring flipping.

An important consequence of the ring flipping is that the axial substituents in the original chair conformation become equatorial in the flipped chair conformation and vice versa. Note that this inversion does not involve any bond breaking or bond forming.

A detailed energy profile for various conformations of cyclohexane is shown in Fig. 3.13. Note that the boat form is a transition state for the interconversion of skew-boat conformations.

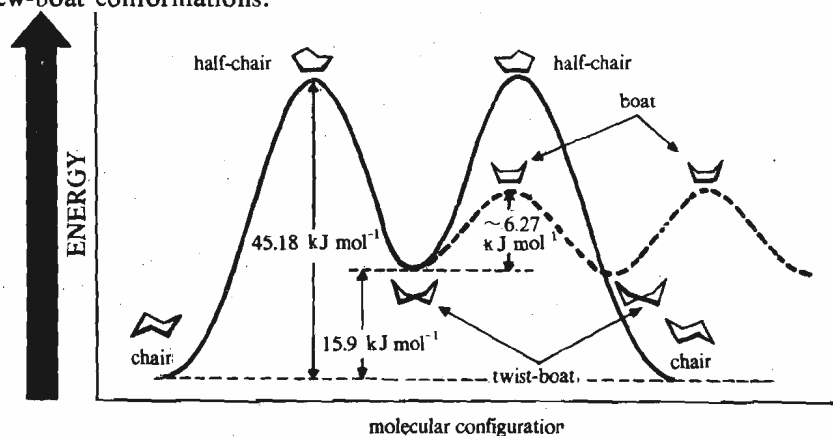
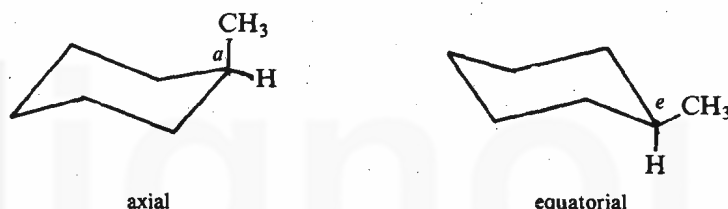

Fig. 3.13 : Relative energies for various conformations of cyclohexane.

### 3.10.2 Conformations of Monosubstituted Cyclohexane Derivatives

Consider a monosubstituted cyclohexane, say, methylcyclohexane. In the chair conformation of methylcyclohexane, the methyl group ( $-\text{CH}_3$ ) can occupy either axial or equatorial position as shown below.



You are advised to use models while studying this section and the next section.

Remember that the ring flipping interconverts these two forms with the methyl group changing from axial to equatorial and vice versa. Also, since these two stereoisomers are not enantiomers, they are diastereomers. They have different energies or different stabilities. Let us now examine what happens when the methyl group occupies the axial position. In this position the methyl group is relatively close to the axial hydrogens at C-3 and C-5 carbon atoms. As the distance between the hydrogen of the methyl group and the C-3 or C-5 hydrogen atom is less than the sum of the van der Waal's radii for the two hydrogens; van der Waal's repulsions destabilise the axial conformation of methylcyclohexane. Such a situation is avoided in the equatorial conformation in which the methyl group occupies equatorial position and hydrogen is axial. The axial hydrogen, being smaller in size as compared to methyl group, experiences smaller van der Waals' repulsions. Thus, equatorial conformation of a monosubstituted

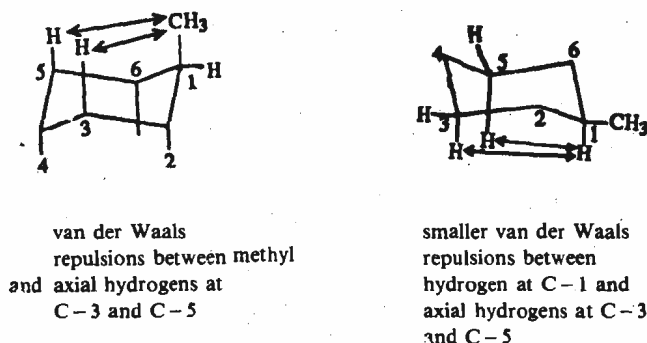

In 1960, Bush Weller was able to separate the equatorial conformation of chlorocyclohexane by cooling its solution in an inert solvent to 123 K.

cyclohexane is more stable as compared to the axial conformation. Since these two conformations are in rapid equilibrium, the relative amounts of the two conformations depend upon the size of the substituent. Thus, for larger substituents, the equilibrium may even be shifted completely to the equatorial conformation. This is illustrated below for some cases.

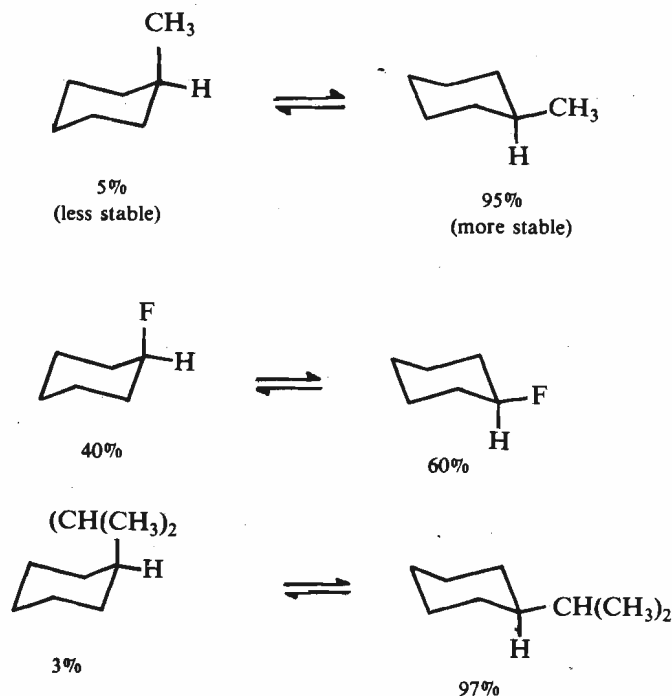

### 3.10.3 Conformations of Disubstituted Cyclohexane Derivatives

When we talk about disubstituted cyclohexanes, the possible patterns of substitution are 1,2-disubstituted, 1,3-disubstituted and 1,4-disubstituted derivatives. Let us study each of these patterns taking dimethylcyclohexane as the example.

#### 1,2-Dimethylcyclohexane

Let one of the methyl groups occupy an axial position at C-1 carbon as shown here,

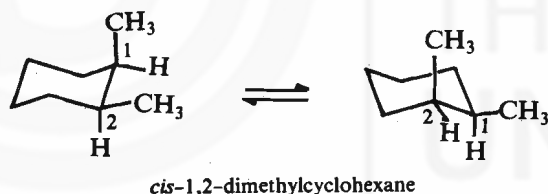

#### Activity

Use models to understand the interactions between the hydrogens of the methyl groups more clearly.

If the second methyl group occupies an equatorial position as represented above, then as both the methyl groups are on the same side, this arrangement is called *cis*. Since the two methyl groups are closer to each other, there is a crowding between the hydrogens of the two methyl groups. Ring flipping of the *cis* form changes it into another equivalent *cis* form. But this does not lead to any change as far as the interactions between the hydrogens of the two methyl groups are concerned.

Another possibility in which both the methyl groups occupy axial position lead to the *trans* arrangement of the groups. Note that this *trans* conformation is

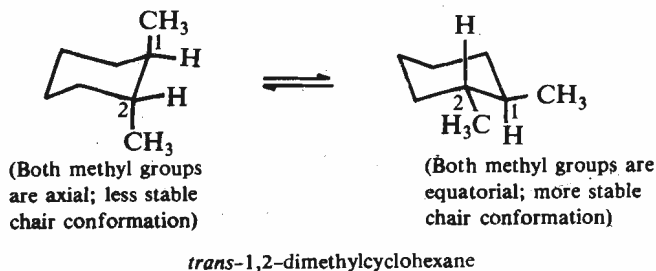

convertible by ring flipping into another conformation in which both the methyl groups occupy equatorial positions. This arrangement is also *trans* because here

also the substituents have the up-down relationship. But these two *trans* arrangements are not equivalent.

## Activity

Convince yourself using models that the two methyl groups at 1 and 2 positions have least van der Waals repulsions with the adjacent hydrogens when they occupy the equatorial positions.

Let us now study about the relative stability of these two *trans* arrangements. Note that the axial  $-\text{CH}_3$  group at C-1 faces van der Waals repulsions by axial hydrogens at C-3 and C-5 carbon atoms. Similar repulsions for the axial C-2 methyl group with hydrogens at C-4 and C-6 carbon atoms, make this diaxial *trans* conformation less stable as compared to the diequatorial *trans* conformation. Note that the equatorial positions are free from such interactions as the substituents project outward from the body of the molecule. Remember, it is a **general rule that any substituent is more stable in the equatorial position than in the axial one.**

Thus, *trans* diequatorial conformation of 1,2-dimethylcyclohexane is more stable than the *trans* diaxial and *cis* forms.

## 1,3-Dimethylcyclohexane

Let the C-1 methyl group in this molecule occupy the axial position. Then, the C-3 methyl group can have either axial or equatorial position.

Let us now study each of these two possibilities one by one.

i) When the C-3 methyl group is axial,



(Both methyl groups are axial; less stable chair conformation)

(Both methyl groups are equatorial; more stable chair conformation)

(Both methyl groups are up)  
*cis*-1,3-dimethylcyclohexane

Then, both the methyl groups are on the same side and you can see that this arrangement is *cis*. Ring flipping of this *cis* conformation leads to another *cis* form in which both methyl groups occupy equatorial positions. (Do it yourself with the models.)

ii) When the C-3 methyl group is equatorial,



(One methyl group is axial, the other is equatorial)

(One methyl group is axial, the other is equatorial)

(One methyl group is up, the other is down)

*trans*-1,3-dimethylcyclohexane

Then, the two methyl groups are said to be *trans* to each other. Ring flipping of this *trans* form yields another equivalent *trans* form. You can verify it using models.

The *trans* form has one methyl group in equatorial position and the other methyl group in the axial position whereas the *cis* form in its more stable conformation has both the methyl group oriented equatorially; therefore, in this case the *cis* form with diequatorial substituents is more stable than the *trans* form. Let us now apply the same considerations to 1,4-dimethylcyclohexane.

## 1,4-Dimethylcyclohexane

Let the C-1 methyl group occupy an axial position. The C-4 methyl group can be either axial or equatorial. Let us consider both these possibilities.

i) When the C-4 methyl group is axial, it leads to the *trans* arrangement of methyl groups. This chair conformation having the diaxial arrangement of methyl groups by ring flipping can change into chair form having diequatorial arrangement of methyl groups.

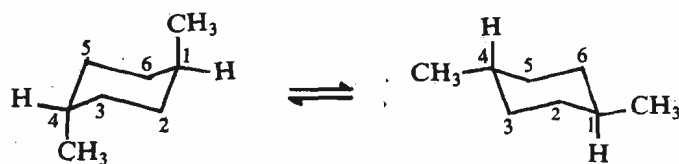

(Both methyl groups are axial: less stable chair conformation)

(Both methyl groups are equatorial: more stable chair conformation)

(One methyl group is up, the other is down)  
*trans*-1,4-dimethylcyclohexane

ii) When the C-4 methyl group is in equatorial position, we have *cis* arrangement of methyl groups. The two equivalent chair conformations shown below represent such an arrangement.

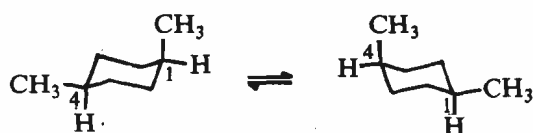

(One methyl group is axial, the other is equatorial)

(One methyl group is axial, the other is equatorial)

(Both methyl groups are up)

*cis*-1,4-dimethylcyclohexane

Note that these two equivalent chair conformations have one axial and one equatorial methyl substituents.

A comparison of these *cis* and *trans* conformations shows that since the *trans* conformation permits both the methyl groups to occupy equatorial sites; hence, it is more stable as compared to the *cis* form which has one substituent each in the axial and equatorial positions.

In other disubstituted cyclohexanes, when the two substituents are different, the stable isomer is the one in which the larger substituent occupies the equatorial position.

Using your knowledge of conformations of cyclohexane systems, answer the following SAQ.

#### SAQ 5

Which of the two isomers in each of the following pairs would be more stable?

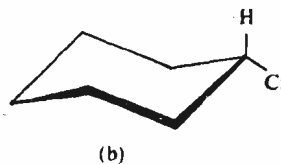
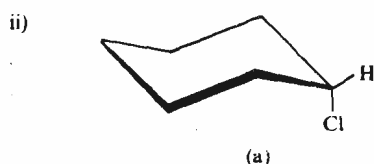
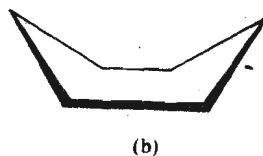
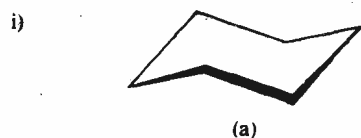

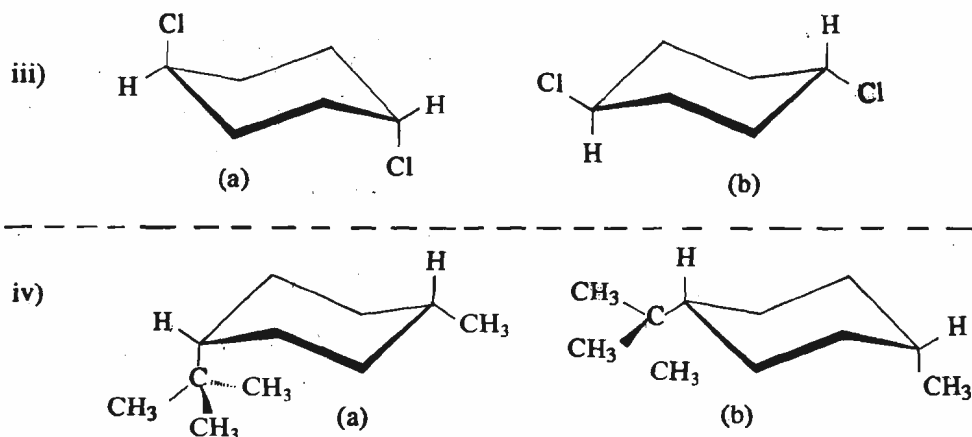

### 3.11 SUMMARY

In this unit, you have learnt that

- The spatial arrangement of the atoms (or groups) in a molecule is known as the configuration.
- Fischer projection formulas are used for representing the configurations of the molecules in the two-dimensional plane of the paper.
- A chiral compound can be assigned an absolute configuration as either *R* or *S* using the Cahn-Ingold-Prelog sequence rules.
- Racemic mixtures can be resolved into optically active compounds via the formation of diastereomers.
- Optically active compounds can be synthesised from optically inactive compounds using asymmetric synthesis.
- Walden inversion involves the inversion of configuration.
- Rotation about carbon-carbon single bond leads to conformational isomers.
- Newman and sawhorse projections are used to represent the conformations of a molecule.
- Staggered conformation of ethane is more stable than its eclipsed conformation.
- Of the three conformations of cyclohexane, namely, chair, boat and skew-boat, the chair conformation is the most stable one.
- Substituents on a cyclohexane ring are more stable when they occupy equatorial position than when they are in axial position.

### 3.12 TERMINAL QUESTIONS

1. Draw Fischer projection formulas for the following compounds:

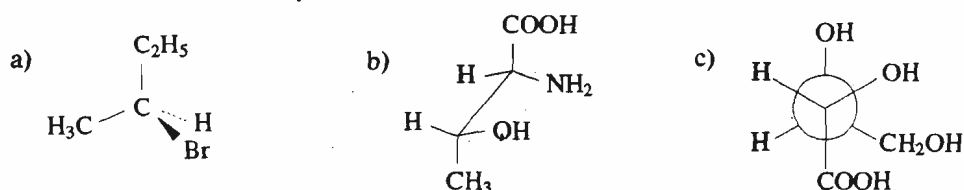

2. a) Write the stereoisomers for tartaric acid (i.e., 2,3-dihydroxybutanedioic acid).
- b) Assign the configuration as *R* or *S* to each chiral centre in each of the stereoisomers in part (a).
- c) Which of the isomers of part (a) are optically active?



3. The resolution of 1-phenylethylamine using (-) malic acid, yielded the less soluble diastereomeric salt having the configuration (*R*)-1-phenylethylammonium (*S*)-malate. The other diastereomeric salt being more soluble remained in the solution. What is the configuration of this more soluble salt?

4. Substituted chiral ethanoic acid having the formula  $\text{DHTC}-\overset{\text{O}}{\parallel}{\text{C}}-\text{OH}$ , in which two hydrogens of the  $\text{CH}_3$  group have been substituted by deuterium, D, and tritium, T, can exist as enantiomers. Write the three dimensional structures for its *R* and *S* isomers.

### 3.13 ANSWERS

#### Self Assessment Questions

1. (a) Same compound, Ist interchange  $-\text{CH}_3$  and  $-\text{OH}$   
 IInd interchange  $-\text{H}$  and  $-\text{C}_3\text{H}_7$ .  
 (b) Same compound, Ist interchange  $-\text{COOH}$  and  $-\text{OH}$   
 IInd interchange  $-\text{OH}$  and  $-\text{H}$ .  
 (c) enantiomers, using rule 3.  
 (d) enantiomers as they are interconvertible by rotation of  $90^\circ$ , (rule 2).
2. (a) *S* (b) *R* (c) *R* (d) *S*.

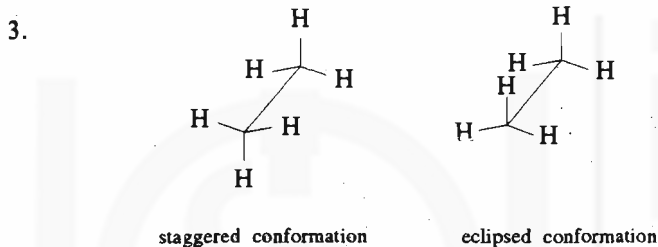

4. (a) Two gauche forms of butane in sawhorse projections:



- (b)  $60^\circ$   
 (c) They are enantiomeric in nature.
5. (i) a (ii) b (iii) b (iv) b

#### Terminal Questions

1. (a)  $\begin{array}{c} \text{C}_2\text{H}_5 \\ | \\ \text{CH}_3 - \text{C} - \text{Br} \\ | \\ \text{H} \end{array}$  (b)  $\begin{array}{c} \text{COOH} \\ | \\ \text{H} - \text{C} - \text{NH}_2 \\ | \\ \text{H} - \text{C} - \text{OH} \\ | \\ \text{CH}_3 \end{array}$  (c)  $\begin{array}{c} \text{OH} \\ | \\ \text{H} - \text{C} - \text{CH}_2\text{OH} \\ | \\ \text{H} - \text{C} - \text{OH} \\ | \\ \text{COOH} \end{array}$
2. (a) i)  $\begin{array}{c} \text{COOH} \\ | \\ \text{HO} - \text{C} - \text{H} \\ | \\ \text{H} - \text{C} - \text{OH} \\ | \\ \text{COOH} \end{array}$  (ii)  $\begin{array}{c} \text{COOH} \\ | \\ \text{H} - \text{C} - \text{OH} \\ | \\ \text{HO} - \text{C} - \text{H} \\ | \\ \text{COOH} \end{array}$  (iii)  $\begin{array}{c} \text{COOH} \\ | \\ \text{H} - \text{C} - \text{OH} \\ | \\ \text{H} - \text{C} - \text{OH} \\ | \\ \text{COOH} \end{array}$

b) (i)  $2S, 3S$  (ii)  $2R, 3R$  (iii)  $2R, 3S$

c) (i) and (ii) are optically active but (iii) being a *meso* compound, is optically inactive.

3. (*S*)-1-phenylethylammonium (*S*)-malate.

4.

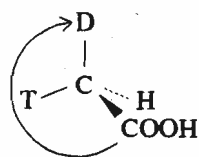

*R* isomer

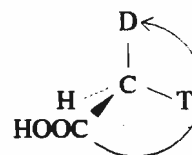

*S* isomer



---

# UNIT 4 EFFECT OF MOLECULAR ARCHITECTURE ON PHYSICAL PROPERTIES

---

## Structure

- 4.1 Introduction
  - Objectives
- 4.2 Molecular Architecture and Physical Properties
  - Intermolecular Forces
  - Melting Point
  - Boiling Point
  - Solubility
- 4.3 General Ideas about Spectroscopy
- 4.4 Ultraviolet Spectroscopy
  - Measurement of Ultraviolet Spectrum
- 4.5 Infrared Spectroscopy
  - Experimental Aspects of Infrared Spectroscopy
- 4.6 Nuclear Magnetic Resonance Spectroscopy
  - How to Obtain an NMR Spectrum
  - Interpretation of Proton NMR Spectrum
- 4.7 Mass Spectrometry
- 4.8 Summary
- 4.9 Terminal Questions
- 4.10 Answers

---

## 4.1 INTRODUCTION

---

In the preceding units we discussed some of the important aspects of bonding and the structures of organic molecules in detail. But have you thought about how we establish the identity and structure of a molecule?

One answer to this question could be comparing its physical and chemical properties with those of the known compounds. Earlier methods of identification involved the determination of physical properties such as melting point, boiling point, solubility and refractive index. The chemical methods used for identification involved, however, either the degradation of the molecule to simple compounds of known structure or its synthesis from the simple compounds of known structure.

In this unit, we will discuss the relationship between molecular structure and physical properties. The study of physical properties is also important in the purification of organic compounds.

Another possibility is that the compound under investigation may be a new compound which has never been studied before and for which no data for comparison is available. For such compounds other methods of structure determination are used. One such method involves the use of various forms of **spectroscopy**. The spectroscopic methods are based on the interaction of molecules with the electromagnetic radiation, their behaviour in a magnetic field or on impingement with high energy electrons. In this unit, you will study some spectroscopic methods such as *ultraviolet (uv) spectroscopy*, *infrared (ir) spectroscopy*, *nuclear magnetic resonance (nmr) spectroscopy* and *mass spectrometry (ms)*. Here, you will also learn how the information available from these methods can be used in determining the molecular structure.

However, the most complete method of structure determination is that of X-ray diffraction. This method provides a detailed picture of the spatial arrangement of various atoms in the molecule. Hence, it enables one to deduce bond lengths, bond angles and other geometrical features of the molecule.

## Objectives

After studying this unit, you should be able to:

- define various kinds of intermolecular forces,
- explain the trends in physical properties such as melting point, boiling point, solubility etc. of molecules on the basis of intermolecular forces,
- correlate the physical properties of the molecules with the molecular structure,
- list various spectroscopic techniques used in the determination of molecular structure,
- predict the type of transitions possible in a molecule when it is subjected to ultraviolet radiation,
- state whether a molecule will show absorptions in the infrared spectrum or not and correlate the absorption bands in the infrared spectrum of a molecule to the functional groups present in it,
- predict the pattern of signals in the nmr spectrum of a given compound,
- write the fragmentation pattern for simple molecules and match it with the peaks obtained in their mass spectra, and
- predict the structure of a molecule from its physical properties and spectral data.

## 4.2 MOLECULAR ARCHITECTURE AND PHYSICAL PROPERTIES

The bonding and structural features of a compound are manifested in its physical properties. Thus, physical properties of a compound such as melting point, boiling point, solubility, etc., often give valuable clues about its structure. Conversely, if the structure of a compound is known, its physical properties can be predicated.

The physical properties of a compound depend upon the number and nature of atoms constituting its structural units and also on the nature of forces holding these units together. You know that in case of ionic compounds, the positive and negative ions are held together by strong electrostatic forces. Contrary to this, in covalent compounds, the molecules are held together by intermolecular forces. Let us now study briefly what these intermolecular forces are. Then, you will learn how these intermolecular forces affect the physical properties of the compounds.

### 4.2.1 Intermolecular Forces

The three important intermolecular forces are: (i) dipole-dipole interactions, (ii) London forces and (iii) hydrogen bonding. Let us now consider these intermolecular forces one by one.

i) **Dipole-dipole interactions** are defined as the interactions between the different molecules of a compound having permanent dipoles. Consider the example of chloromethane which has a permanent dipole. The molecules of chloromethane orient themselves in such a way that the positive end of one dipole points towards, and is thus attracted by, the negative end of the other dipole. These interactions, called dipole-dipole interactions are depicted in Fig. 4.1.

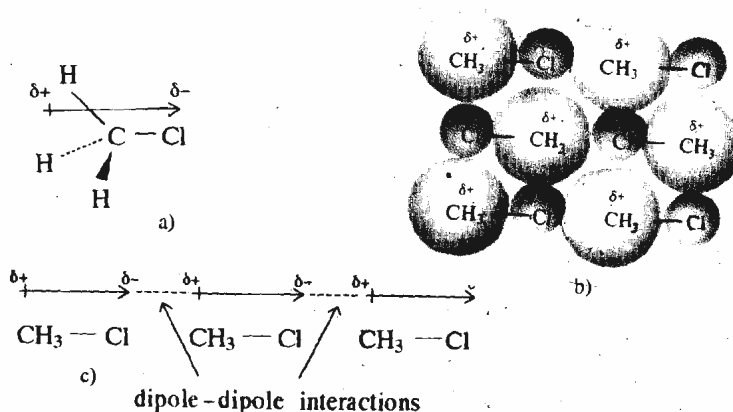

Fig. 4.1 : a) A polar chloromethane molecule showing positive and negative poles. b) Arrangement of chloromethane molecules and c) Dipole-dipole interactions between chloromethane molecules.

The dipole-dipole interactions are weak interactions and are of the order of 4 to 12  $\text{kJ mol}^{-1}$  whereas the bond energy for an ordinary covalent bond ranges from 125 to 420  $\text{kJ mol}^{-1}$ .

## ii) London forces

The intermolecular interactions exist between nonpolar molecules also. Consider two nonpolar molecules A and B in which the centre of positive charge coincides with that of the negative charge



When the molecules A and B approach each other, there is a distortion in the distribution of the charge resulting in a small and momentary dipole in one molecule. This small dipole can then create another dipole in the second molecule which is called **induced dipole**. Thus, if the momentary dipole of molecule A is as shown below;



then, this leads to an induced dipole in molecule B as shown below:



Such a distribution of charge leads to mutual attraction between the molecules. These **induced dipole-induced dipole** interactions are also known as **London forces**. These interactions are weaker than the dipole-dipole interactions and are of the order of 4  $\text{kJ mol}^{-1}$ . These forces vary with the distance between the molecules. If  $r$  is the distance between the two molecules, then the London forces are proportional to  $1/r^6$ .

London forces are the only forces of attraction possible between nonpolar molecules.

iii) **Hydrogen bonding** results when a hydrogen atom is covalently bonded to a strongly electronegative atom such as oxygen, nitrogen or fluorine. Such a hydrogen atom has a large affinity for the nonbonded electrons of oxygen (or nitrogen or fluorine) atom of the other molecule. This type of intermolecular interaction is known as hydrogen bonding. The hydrogen bonding in case of ethanol is represented below:

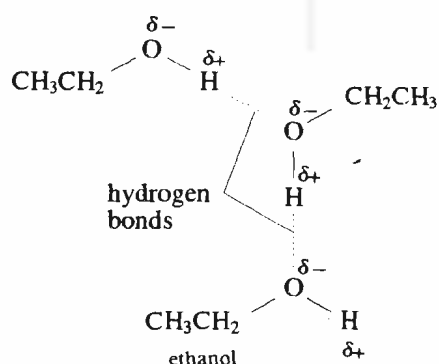

The hydrogen bonding is a special type of dipole-dipole interaction.

Note that the hydrogen bonds are indicated by the dash lines whereas the covalent bonds are represented by solid lines.

The hydrogen bonding is a stronger interaction as compared to the dipole-dipole interactions but it is weaker than a covalent bond. The strength of a hydrogen bond ranges from 10 to 40  $\text{kJ mol}^{-1}$ . Hydrogen bonding has an important influence on physical properties such as melting point, boiling point and solubility of substances. This will be illustrated using examples in the following subsections.

The dipole-dipole, induced dipole-induced dipole etc. interactions are collectively known as **van der Waals forces**. Having understood the intermolecular forces, let us now study how the variation in molecular structure affects these intermolecular forces which in turn is reflected in the physical properties of the molecules.

Some authors prefer to give the name van der Waals forces only for London forces.

### 4.2.2 Melting Point

The **melting point** of a substance can be defined as the temperature at which it undergoes the transition from the solid to the liquid state.

Pure crystalline solids have sharp melting points and they melt over a temperature range of  $1^\circ$  or less. In contrast to this, impure crystalline solids melt over wider ranges of temperature.

Pure crystalline solids have **sharp** melting points. Thus, melting point is used as an important physical property both for the identification of organic compounds and for making the general assessment of the purity of these compounds. In a crystalline solid, the constituent ions or molecules are arranged in an orderly and rigid fashion. When such a solid is heated, the thermal energy of the molecules increases. This finally leads to the disintegration of the crystal structure and at the melting point a disorderly and random arrangement of particles, characteristic of a liquid, is obtained. Since the electrostatic forces holding the ions are very strong, they can be overcome only at high temperatures. Therefore, the ionic compounds generally have high melting points. For example, the melting point of sodium chloride is 1074 K and that of sodium ethanoate is 595 K. But, the **intermolecular** forces are very weak as compared to the **interionic** forces and hence, these can be overcome at lower temperatures leading to lower melting points for covalent compounds. The melting point of methane, a covalent compound, is only 90 K and the melting point of methanol, another covalent compound, is 179 K.

Let us now study the effect of molecular weight on the melting point. The relationship between molecular weight and melting point for alkanes is illustrated in Fig. 4.2.

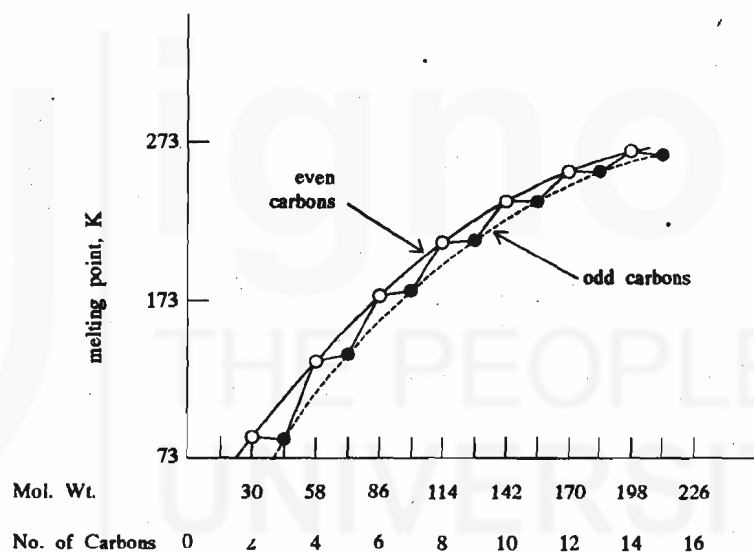

Fig. 4.2 : Plot of melting points of straight chain alkanes against the molecular weight; the number of carbon atoms present in alkane molecule are also indicated.

In a homologous series, the higher the molecular weight, the larger will be the molecules and the greater will be the 'area of contact' between the two molecules and hence the greater will be the London forces.

You can see in the figure that the melting point increases with the increase in the molecular weight. This can be explained due to increase in the London forces between the larger molecules of higher molecular weight. Thus, each additional methylene ( $-\text{CH}_2$ ) unit contributes to the increase in melting point.

You must have noticed in Fig. 4.2, the alternating pattern of melting points for the alkanes having odd and even number of carbon atoms. It is also evident from the figure that the compounds having even number of carbon atoms lie on a higher curve as compared to the compounds having odd number of carbon atoms. This can be explained on the basis that in solid state, the London forces among the molecules having odd number of carbon atoms are weaker than those in the molecules having even number of carbon atoms. This is because the molecules of alkanes having odd number of carbon atoms do not fit well in the crystal lattice as compared to those of the alkanes having even number of carbon atoms.

After studying the effect of molecular weight on melting point, let us now see how the isomeric compounds having the same molecular weight, show different melting points. The melting points of straight chain and branched chain isomers of butane are given below.

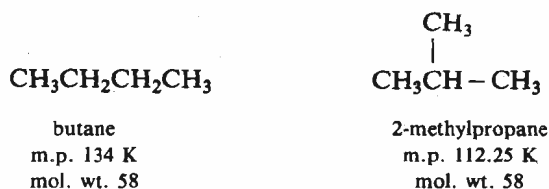

The branching of the carbon chain interferes with the regular packing of the molecules in the crystal; hence, branched chain hydrocarbons tend to have lower melting points than their straight chain isomers.

But, in case, the branched molecule has a substantial symmetry, then its melting point is relatively high. This is clearly evident when we compare the melting points of isomeric pentanes which are as given below:

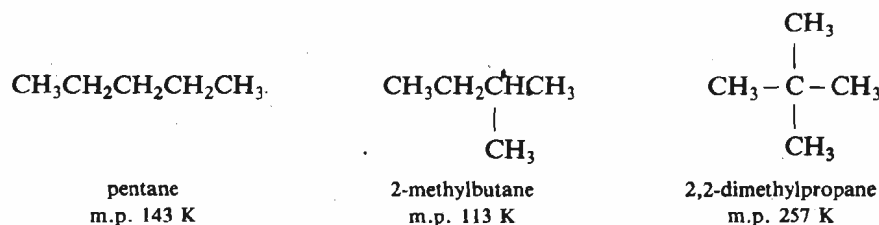

The branching from pentane to 2-methylbutane lowers the melting point but further branching in 2,2-dimethylpropane increases the melting point. This can be explained by the fact that the symmetrical molecules fit together more easily in the crystal lattice and hence have higher melting points as compared to the less symmetrical molecules. Hence, higher melting point for 2,2-dimethylpropane is justified.

This is also reflected when we analyse the melting points of *cis*- and *trans*-isomers. The *trans*- isomer being more symmetrical, fits better in the crystal lattice than the less symmetrical *cis*- isomer. Hence, the *trans*- isomers generally have higher melting points, (see Table 2.1, Unit 2).

The nature of the functional groups present in a molecule also affects its physical properties. For example, when the functional group is such that it introduces polarity, and hence leads to a permanent dipole moment in the molecule; then, due to the dipole-dipole forces of attraction between the polar molecules, they show higher melting points than the nonpolar molecules of comparable molecular weights. For example, the melting point of propanone, a polar molecule having molecular weight of 58, is 178 K. You can compare it with the melting points of isomers of nonpolar butane (mol. wt. = 58) you have just studied above. This leads to the conclusion that the polar propanone has higher melting point than the nonpolar isomeric butanes.

The effect of hydrogen bonding on melting point is small. But, the hydrogen bonding has significant effect on the boiling point, about which you will study in the following subsection.

### 4.2.3 Boiling Point

The **boiling point** of a substance is the temperature at which it changes from the liquid to the gaseous state. At the boiling point the vapour pressure of a liquid is equal to the external pressure. Thus, the boiling point depends on the external pressure and it increases with increase in the external pressure. Hence, while reporting the boiling point of a substance, external pressure must be specified. Normally, the boiling points are reported at atmospheric pressure.

Similar to the case of melting points, the boiling points are also used as constants for identification and characterisation of liquid substances. The knowledge of boiling points is also important in the purification of liquids. Let us now study some of the factors affecting the boiling point.

The boiling point of a substance depends on its molecular structure. In a homologous series, the boiling points of the compounds increase with the increase

in the number of carbon atoms. In other words, we can say that the boiling point increases with increase in molecular weight. Generally, this increase in boiling point amounts to 20–30° for the addition of each carbon atom in the molecule. The increase in boiling point with molecular weight can be again attributed to increased London forces of attraction between larger molecules.

Among isomeric molecules, since the unbranched isomer is linear and hence extended in shape, it has larger surface area as compared to the branched isomers. Therefore, the London forces are stronger in the unbranched isomer leading to higher boiling point for this isomer. This is illustrated in Fig. 4.3 for the isomers of butane.

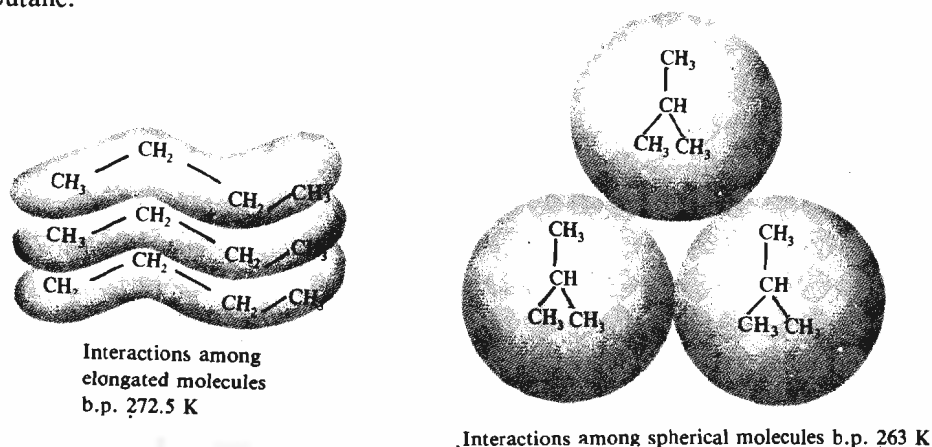
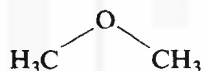

Fig. 4.3 : A comparison of intermolecular interactions for straight chain and branched chain isomers of butane.

The polarity of a compound also affects its boiling point. When we compare molecules having the same shape and size, the more polar molecule has the higher boiling point. Examples are,



Dimethyl ether

dipole moment	$20.98 \times 10^{-30} \text{C m}$
boiling point	249.4 K
molecular weight	46

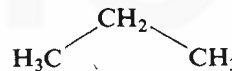

propane

dipole moment	~ 0
boiling point	231 K
molecular weight	44

Alcohols have unusually high boiling points as compared to the other compounds of comparable molecular weight or size. For example, ethanol  $\text{CH}_3\text{CH}_2\text{OH}$ , which has the same molecular formula as that of dimethyl ether, has the boiling point 351 K. This can be explained due to hydrogen bonding. Hydrogen bonding for ethanol has been illustrated earlier in sub-Sec. 4.2.1. Thus, to vaporise such a compound, hydrogen bonds between the molecules must be broken. This requires energy which is manifested as the unusually high boiling point for such compounds.

The hydrogen bonding as shown for ethanol is known as **intermolecular hydrogen bonding** which means that the hydrogen bonds are present **between** the molecules.

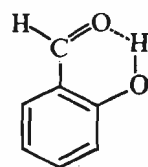

Intramolecular hydrogen bonding

2-hydroxybenzaldehyde  
b.p. 470 K

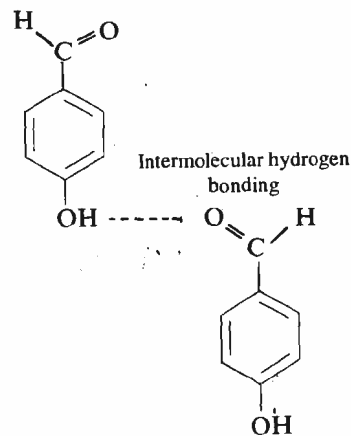

4-hydroxybenzaldehyde  
b.p. 523 K



Hydrogen bonding can also occur within the same molecule in which case it is called **intramolecular hydrogen bonding**. Thus, 2-hydroxybenzaldehyde shows **intramolecular** hydrogen bonding whereas its *p*-isomer, 4-hydroxybenzaldehyde can form only **intermolecular** hydrogen bonds.

The increased intermolecular attraction due to intermolecular hydrogen bonding is reflected in the higher boiling point for 4-hydroxybenzaldehyde as compared to 2-hydroxybenzaldehyde in which this intermolecular interaction is absent.

Hydrogen bonding is also important in other ways. As we shall see in the next subsection, hydrogen bonding plays an important role in the solubility of organic compounds.

#### 4.2.4 Solubility

When any substance dissolves in a solvent, its constituent ions or molecules get separated from each other and the space between them is filled by solvent molecules. This is known as *solvation* and the amount of substance dissolved in a certain amount of solvent is referred to as its *solubility* in that solvent. Solubility, thus depends on the interactions between solute-solute, solute-solvent and solvent-solvent molecules. Clearly strong solute-solvent molecular interactions as compared to those of solute-solute or solvent-solvent molecules will lead to dissolution of the solute.

Similar to the processes of melting or boiling, dissolution of a substance also requires that the interionic or intermolecular forces of attraction between the ions or molecules must be overcome. The strong electrostatic forces between the ions of an ionic compound can be overcome by the solvents which have high dielectric constant. Thus, water which has a high dielectric constant of 80, dissolves ionic compounds readily whereas solvents like carbon tetrachloride ( $\epsilon = 2.2$ ) or ether ( $\epsilon = 4.4$ ) are extremely poor solvents for such compounds. Hence, ionic compounds have greater solubility in *polar* solvents.

In determining the solubility of covalent compounds, the rule of thumb is **like-dissolves-like**. Since water is a polar compound, it is a good solvent for polar compounds, but is a poor solvent for hydrocarbons which are nonpolar in nature. Thus, the hydrocarbons readily dissolve in other hydrocarbons or in nonpolar solvents such as benzene, ether or tetrahydrofuran. As most organic compounds have both a polar and a nonpolar part, their solubility will depend upon the balance between the two parts. Consider the solubilities of three alcohols, ethanol, butanol and hexanol in water, as given below:

nonpolar part ↓	polar part ↓	nonpolar part ↓	nonpolar part ↓
$\text{CH}_3 - \text{CH}_2 - \text{OH}$	$\text{CH}_3\text{CH}_2\text{CH}_2\text{CH}_2\text{OH}$	$\text{CH}_3\text{CH}_2\text{CH}_2\text{CH}_2\text{CH}_2\text{OH}$	
ethanol	butanol	hexanol	
Solubility : miscible with water in all proportions	7.9 g in 1 dm <sup>3</sup> of water	5.9 g in 1 dm <sup>3</sup> of water	

You can notice that as the size of the nonpolar portion of the molecule increases, its solubility in water decreases.

The solubility of organic compounds in water also depends on the extent of hydrogen bonding possible between the solute and the solvent (water) molecules. For example, the greater solubility of ether in water as compared to that of pentane (in water) can be accounted on the basis of hydrogen bonding present in the former case.

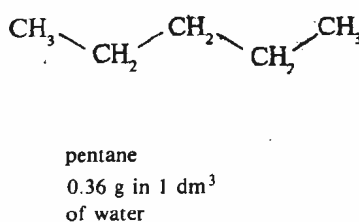
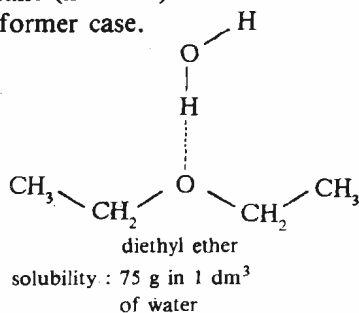

The dielectric constant,  $\epsilon$ , of a solvent measures its ability to separate the ions of the solute.

The term **polar** has double usage in organic chemistry. When we refer to a **polar molecule**, we mean that it has a significant dipole moment,  $\mu$ . But, when we talk about a **polar solvent**, we understand that it has a high dielectric constant,  $\epsilon$ . Thus, the dipole moment is the property of individual molecules whereas solvent polarity or dielectric constant is a property of many molecules acting together.

Solvent ether refers to diethyl ether.



Tetrahydrofuran, is abbreviated as THF.

1 dm<sup>3</sup> = 1 litre

1 dm<sup>3</sup> = 1 litre

Since the olefinic, acetylenic or benzenoid character does not affect the polarity much, the solubility of unsaturated and aromatic hydrocarbons in water is similar to that of alkanes. In compounds like ethers, esters, aldehydes, ketones, alcohols, amides, acids and amines, solubility in water depends on the length of the alkyl chain and the members containing less than five carbon atoms in the molecules are soluble in water.

Polymers have high molecular weight.

Increase in the intermolecular forces in a solute, as a result of increase in the molecular weight, is also reflected in the low solubility of compounds having high molecular weight. For example, glucose is soluble in water but its polymer, starch is insoluble in water. Thus, in a homologous series, the solubility of the members decreases with the increase in molecular weight. However, branching of the carbon chain leads to a decrease in the intermolecular forces. Hence, the branched chain isomer is more soluble as compared to the straight chain isomer.

Apart from other factors discussed above, solubility of a compound in a given solvent generally increases with temperature.

Sometimes high solubility of a compound is observed due to a chemical reaction which acts as a driving force. One such category of reactions is acid-base reactions. For example, the higher solubility of aniline in aqueous acid is due to the formation of anilinium ion.

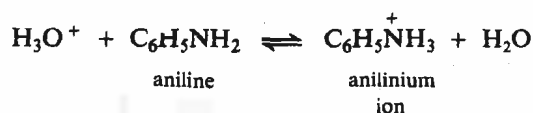

Although determination of the physical properties such as those discussed above helps in the identification of organic compounds, physical methods involving the use of spectroscopy allow determination of the molecular structure much more rapidly and nondestructively using small quantities of material. There are many kinds of spectroscopic methods available, but we will restrict our discussion only to **ultraviolet spectroscopy, infrared spectroscopy, nuclear magnetic resonance spectroscopy and mass spectrometry** because these are used most frequently in organic chemistry. In this unit, we will study each one of these in detail. But before studying the next section, answer the following SAQ to check your understanding about the relationship between the physical properties and molecular structure.

#### SAQ 1

Classify the following statements as **true** or **false**.

- i) London forces are the only forces operating between polar molecules.  
.....
- ii) Within a homologous series, increase in molecular weight leads to decrease in the melting point.  
.....
- iii) Highly symmetrical molecules have unusually high melting points.  
.....
- iv) The shape of a molecule does not affect its boiling point.  
.....
- v) Polar compounds generally boil at higher temperatures as compared to the nonpolar compounds.  
.....
- vi) Hydrogen bonding increases the water solubility.  
.....

### 4.3 GENERAL IDEAS ABOUT SPECTROSCOPY

Before studying the various kinds of spectroscopic techniques in detail, let us refresh our knowledge of some of the concepts you studied in Units 1, 7 and 8 of Atoms and Molecules course.

You are already aware that **spectroscopy** is the study of the interaction of matter and energy, or more generally, the electromagnetic radiation. You may recall that the **energy, frequency and wavelength** of electromagnetic radiation are related by the following expression:

$$E = h\nu = \frac{hc}{\lambda} \quad \dots(4.1)$$

where  $E$  is the energy,  $\nu$  is the frequency and  $\lambda$  is the wavelength of electromagnetic radiation whereas  $h$  is Planck's constant and has the value  $6.626 \times 10^{-34}$  J s. Here,  $c$  is the velocity of light and is equal to  $2.998 \times 10^8$  m s<sup>-1</sup>.

The total range of electromagnetic radiation is called the **electromagnetic spectrum**. There are various types of radiations within the electromagnetic spectrum which are shown in Fig. 4.4.

Description	Wavelength Range	Wave Number cm <sup>-1</sup>	Frequency Hz	Energy kJ mol <sup>-1</sup>
Radio frequency	{ 3 × 10 <sup>3</sup> m 0.30 m	{ 3.33 × 10 <sup>-6</sup> 0.0333	{ 10 <sup>5</sup> 10 <sup>9</sup>	{ 3.98 × 10 <sup>-8</sup> 3.98 × 10 <sup>-4</sup>
Microwave	{ 0.0006 m (600 μm)	{ 16.6	{ 4.98 × 10 <sup>11</sup>	{ 0.191
Far infrared	{ 30 μm	{ 333	{ 10 <sup>13</sup>	{ 3.98
Near infrared	{ 0.8 μm	{ 1.25 × 10 <sup>4</sup>	{ 3.75 × 10 <sup>14</sup>	{ 149.8
Visible	{ (800 nm) 400 nm)	{ 2.5 × 10 <sup>4</sup>	{ 7.5 × 10 <sup>14</sup>	{ 299.2
Ultraviolet	{ 150 nm	{ 6.66 × 10 <sup>4</sup>	{ 19.98 × 10 <sup>14</sup>	{ 795
Vacuum ultraviolet	{ 5 nm	{ 2 × 10 <sup>6</sup>	{ 6 × 10 <sup>16</sup>	{ 2.39 × 10 <sup>4</sup>
X rays and γ rays	{ 10 <sup>-4</sup> nm	{ 10 <sup>11</sup>	{ 3 × 10 <sup>21</sup>	{ 1.19 × 10 <sup>9</sup>

1 millimetre  
= 1 mm = 10<sup>-3</sup> m  
  
1 micrometre  
= 1 μm = 10<sup>-6</sup> m  
  
1 nanometre  
= 1 nm = 10<sup>-9</sup> m  
  
1 picometre  
= 1 pm = 10<sup>-12</sup> m  
= 0.01 Angstrom Unit  
= 0.01 Å

Fig. 4.4 : The Electromagnetic Spectrum.

The most common type of spectroscopy used for structure determination of organic compounds is **absorption spectroscopy**. You are already aware from Unit 7, Block 1 of Atoms and Molecules course that absorption spectroscopy is based on the absorption of energy from certain regions of electromagnetic radiation by molecules. Since the different regions of electromagnetic radiation have different energies, the absorption of energy from different regions of electromagnetic radiation leads to different forms of spectroscopy as is shown in Fig. 4.4. Such an absorption of energy can be determined using an instrument called a **spectrophotometer** and is expressed either in terms of wavelength or frequency or wavenumber. The components of such a spectrophotometer are shown in Fig. 4.5.

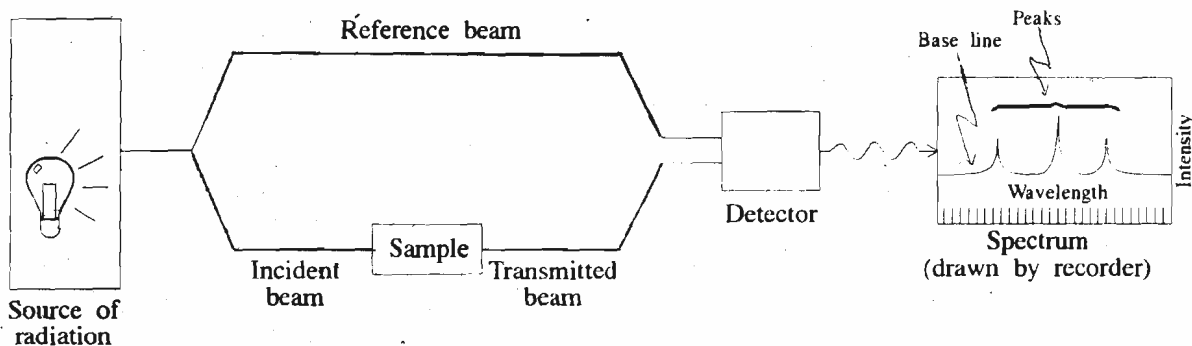

Fig. 4.5 : A schematic diagram of spectrophotometer.

**Spectrum** is a Latin word meaning *appearance* and it refers to the appearance of characteristic recorded lines.

As is illustrated in the figure, a source of electromagnetic radiation is required. The **sample** is placed in the radiation beam and the intensity of radiation absorbed by the sample is measured by the **detector**. Then, the wavelength (or frequency) of the radiation is varied and the radiation absorbed at each wavelength is recorded as a graph of either radiation transmitted or radiation absorbed versus the wavelength or the frequency. This graph is called the **spectrum** of the sample.

When a molecule is exposed to electromagnetic radiation, it absorbs energy corresponding to certain specific wavelengths, thereby passing from the lower energy level to the higher energy level. The particular quantity of energy absorbed by the molecule depends on the molecular structure and hence, it indicates the presence of a structural feature capable of absorbing that particular package of energy.

Many different kinds of excitations are possible in a molecule depending upon the amount of energy absorbed, which in turn is determined by the energy of the incident electromagnetic radiation. For example, the absorption of ultraviolet and visible radiation can move valence-shell electrons, particularly from a filled bonding molecular orbital to a vacant antibonding molecular orbital. Similarly, absorption of radiation from the infrared region can cause vibrational changes in the molecular framework. However, the absorption of radio waves can reorient nuclear spins and change the magnetic properties of certain atomic nuclei. This phenomenon forms the basis of nuclear magnetic resonance spectroscopy. The fourth kind of spectroscopic technique, i.e., mass spectrometry is fundamentally different from UV, IR and NMR spectroscopy in the sense that it is not an absorption spectroscopy.

As each of these methods yields a different kind of information about molecular structure, let us now study what the ultraviolet spectroscopy can tell us.

#### 4.4 ULTRAVIOLET SPECTROSCOPY

Since the absorption of energy corresponding to the ultraviolet and visible regions of the electromagnetic spectrum results in the transitions between electronic energy levels of the molecule, the ultraviolet and visible spectroscopy is collectively also known as **electronic spectroscopy**.

The ultraviolet and visible regions range from the wavelength 200 nm to 400 nm and 400 nm to 800 nm, respectively. The absorption of energy in this region results in the transfer of electron(s) from bonding and nonbonding orbitals to antibonding orbitals. Hence, the wavelength of the light absorbed will depend upon the energy difference between the ground state and the excited state of the molecule. This difference will in turn indicate the energy difference between the orbitals of the molecule. For example, in saturated hydrocarbons which contain C-C and C-H single bonds, the possible electronic transitions are from  $\sigma$  bonding orbitals to  $\sigma^*$  antibonding orbitals. Since the energy required for these transitions is high, radiation of higher energy or very low wavelengths, i.e. below 200 nm are required for these transitions to take place. For recording the spectrum in this range of the electromagnetic spectrum, air has to be removed because it also absorbs radiation below 200 nm; therefore, this region is known as **extreme or vacuum ultraviolet spectral region**. On the other hand, molecules containing *pi* bonds can undergo  $\pi \rightarrow \pi^*$  transitions, as shown in Fig. 4.6. Electronic transitions involving nonbonding electrons are also possible in which case the nonbonding electrons can be excited to  $\sigma^*$  and  $\pi^*$  higher energy states. The  $n \rightarrow \pi^*$  transitions occur commonly in compounds containing double bonds involving the heteroatoms such as oxygen, sulphur and nitrogen. For example, the compounds containing the structural units such as  $>C=O$ ,  $>C=S$  and  $>C=N$  show  $n \rightarrow \pi^*$  transitions.

As is evident from Fig. 4.6, various transitions can be arranged in the decreasing order of their energy as shown below.

The position of absorption in the uv and visible spectra is expressed in the units of  $10^{-9}$  m or nanometer (nm).

$\pi \rightarrow \pi^*$  is read as *pi* to *pi* star.

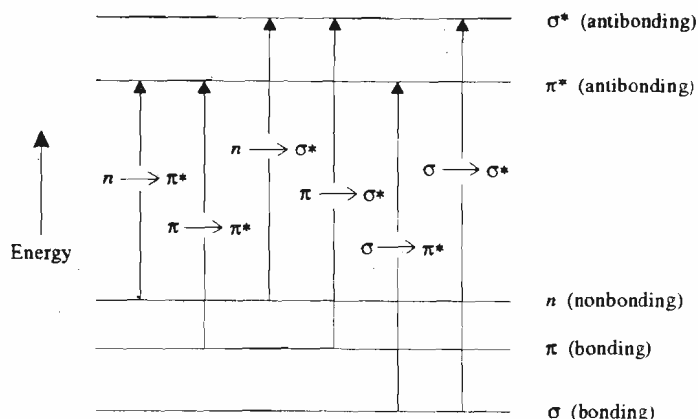

Fig. 4.6 : Energy changes associated with various possible electronic transitions in a molecule.

$$\sigma \rightarrow \sigma^* > \sigma \rightarrow \pi^* \sim \pi \rightarrow \sigma^* > n \rightarrow \sigma^* \pi \rightarrow \pi^* > n \rightarrow \pi^*$$

The structural units associated with these transitions are called **chromophores**. Some of the important chromophores include the unconjugated chromophores of the type,  $C=C$ ,  $C \equiv C$ ,  $C=O$ ,  $C \equiv N$  and the conjugated ones such as  $C=C-C=C$ ,  $C=C-C=O$  and benzene.

Here you may ask, is there any difference between the UV spectra of conjugated and unconjugated molecules and if there is a difference, what is the effect of conjugation on the wavelength of radiation absorbed? Before studying these aspects, it is necessary that you know how a UV spectrum looks like and what information about molecular structure is available from it. To understand this, look at the UV spectrum of 2-methyl-1,3-butadiene as shown in Fig. 4.7. You can see in the figure that the horizontal axis shows the **wavelength**,  $\lambda$ , of the ultraviolet

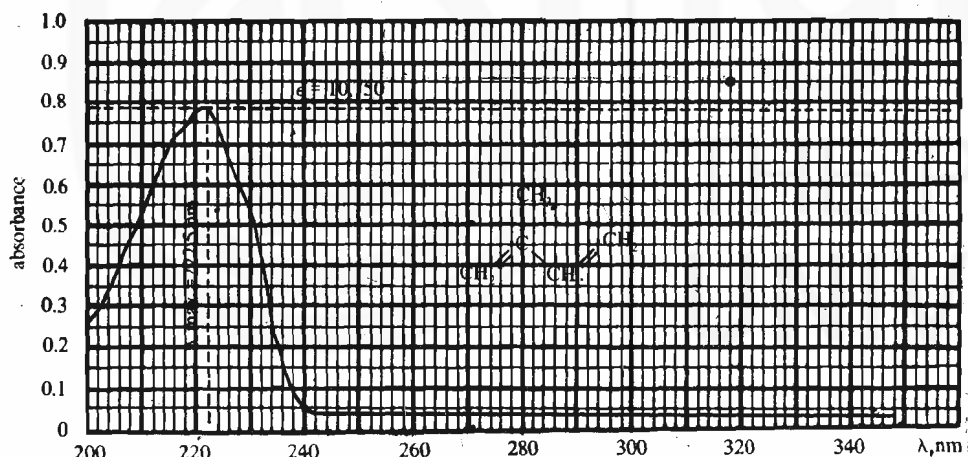

Fig. 4.7 : Ultraviolet spectrum of 2-methyl-1,3-butadiene in methanol.

radiation and the vertical axis shows **absorbance**,  $A$ . The absorbance is a measure of the amount of radiant energy absorbed. If a radiation having the intensity  $I_0$  enters the sample and the radiation leaving the sample has the intensity,  $I$ , then the absorbance,  $A$ , is given by the log of the ratio  $I_0/I$ . Thus,

$$A = \log \left( \frac{I_0}{I} \right) \quad \dots(4.2)$$

Hence, the larger the ratio  $I_0/I$ , the greater is the absorbance and the more is the radiant energy absorbed. The wavelength at which the absorption is maximum is referred to as  $\lambda_{\max}$  of the sample. As shown in Fig. 4.7, for 2-methyl-1,3-butadiene,  $\lambda_{\max}$  is 222.5 nm.

As the absorbance at a given wavelength depends on the number of molecules present in the path of the radiation, it is proportional to the concentration,  $c$  (expressed in moles  $\text{dm}^{-3}$ ) of the solution multiplied by the path length,  $l$ , i.e.,

$$A \propto cl$$

$$\text{or } A = \epsilon cl \quad \dots(4.3)$$

Originally, the term *chromophore* was used to denote the system responsible for imparting colour to a compound. In Greek, **chromophorous** means colour carrier.

Multiple bonds which are separated from each other by a single bond are said to be **conjugated**. Compounds containing conjugated bonds have unique structures and chemical properties about which you will study in Units 7 and 9 of Block 2 of this course.

*Absorbance* is also known as optical density.

$\lambda_{\max}$  is read as lambda-max.

## Fundamental Concepts





Note that the  $\epsilon$  has been used earlier to denote the dielectric constant also.

Substitution of  $A$  from Eq. 4.2 into Eq. 4.3 yields  $\log(I_0/I) = \epsilon cl$  or  $\epsilon = A/cl$  which is the expression for Beer-Lambert law. You can refer to Sec. 8.11 of Unit 8, Block 2 of Atoms and Molecules course where Beer-Lambert law was discussed in detail.

where the constant of proportionality,  $\epsilon$ , is called the **molar absorptivity** or **molar extinction coefficient**. It is a measure of the probability of the transition. The molar extinction coefficient has characteristic value for each absorption of the compound. Hence, quantitative determination of ultraviolet spectrum requires the specification of both  $\lambda_{\max}$  and  $\epsilon$  values. Since both  $\lambda_{\max}$  and  $\epsilon$  values are affected by the solvent, the solvent used for measurement is also to be indicated while reporting the ultraviolet spectral data. Hence, the description of the uv spectrum of 2-methyl-1,3-butadiene will be given as  $\lambda_{\max} = 222.5 \text{ nm}$  ( $\epsilon = 10,750$ ), in methanol.

We are now in a position to interpret the uv spectral data for some alkenes given in Table 4.1.

**Table 4.1.** : UV Absorptions for some alkenes.

Alkene	$\lambda_{\max}$	$\epsilon/m^2 \text{ mol}^{-1}$
$\text{CH}_2 = \text{CH}_2$	175	15,000
	178	not known
	217	21,000
	222.5	10,750
	268	34,600

Conjugation increases wavelength of absorption by decreasing the energy difference between the ground and excited states.

The  $\lambda_{\max}$  for ethene which has one double bond, was found to be 175 nm. You can compare the  $\lambda_{\max}$  value of 1,4-pentadiene which is equal to 178 nm with that of 1,3-butadiene or 2-methyl-1,3-butadiene which have  $\lambda_{\max}$  217 nm and 222.5 nm, respectively. Note that all the three compounds have two double bonds which are isolated or nonconjugated in case of 1,4-pentadiene but are conjugated in 1,3-butadiene and 2-methyl-1,3-butadiene. Thus, conjugated molecules absorb at longer wavelengths as compared to the nonconjugated ones. Further extension of conjugation, as in 1,3,5-hexatriene leads to a  $\lambda_{\max}$  value of 268. Hence, **the longer the conjugated system, the higher will be the  $\lambda_{\max}$  value**. And, if in a molecule, the conjugation is large enough to yield a large  $\lambda_{\max}$  value which lies in the visible region of the spectrum, then the compound will appear coloured. For example,  $\beta$ -carotene (which imparts red colour to carrots and is also a precursor of vitamin A) has 11 conjugated double bonds and  $\lambda_{\max}$  value of 497 nm.

In general, polyenes containing eight or more conjugated double bonds absorb light in the visible region of the spectrum.

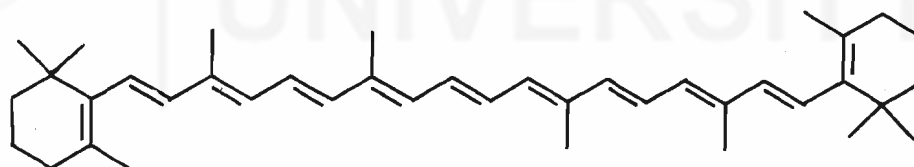

$\beta$ -carotene

Light of wavelength 497 nm has a blue-green colour and when this blue-green light is absorbed by  $\beta$ -carotene, we perceive the complementary colour of blue-green which is red-orange. Similarly, lycopene, a red pigment of ripe tomatoes which also has a conjugated system containing 11 double bonds shows  $\lambda_{\max} = 505 \text{ nm}$  which also lies in the visible region of the electromagnetic spectrum.

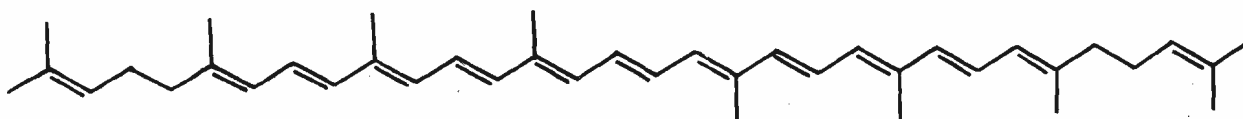

lycopene

When we are talking about the coloured compounds it is worthwhile to mention here about the **auxochromes**. An auxochrome can be defined as a group that can enhance the colour-imparting properties of a chromophore, although it is not a chromophore itself. Examples of auxochromes include groups of the type  $-\text{OR}$ ,  $-\text{NH}_2$ ,  $-\text{NR}_2$ , etc. where R denotes an alkyl group.

In addition to the conjugation, other factors such as the presence of substituent groups on the double bond and spatial arrangement of the double bonds also influence the  $\lambda_{\max}$  value. You can see in Table 4.1 that the presence of methyl group in 2-methyl-1,3-butadiene increases the  $\lambda_{\max}$  value by 5.5 nm as compared to that of 1,3-butadiene. Similarly, the presence of second alkyl group in 2,3-dimethyl-1,3-butadiene leads to an increase of 9 nm in  $\lambda_{\max}$  value as compared to that of the unsubstituted compound.

#### 4.4.1 Measurement of UV spectrum

The ultraviolet-visible spectrum of a compound can be recorded using an instrument called ultraviolet-visible spectrophotometer. The components of a UV-visible spectrophotometer are shown in Fig. 4.8 but here we will not go into the details of instrumentation. As the figure shows, the source of ultraviolet-visible

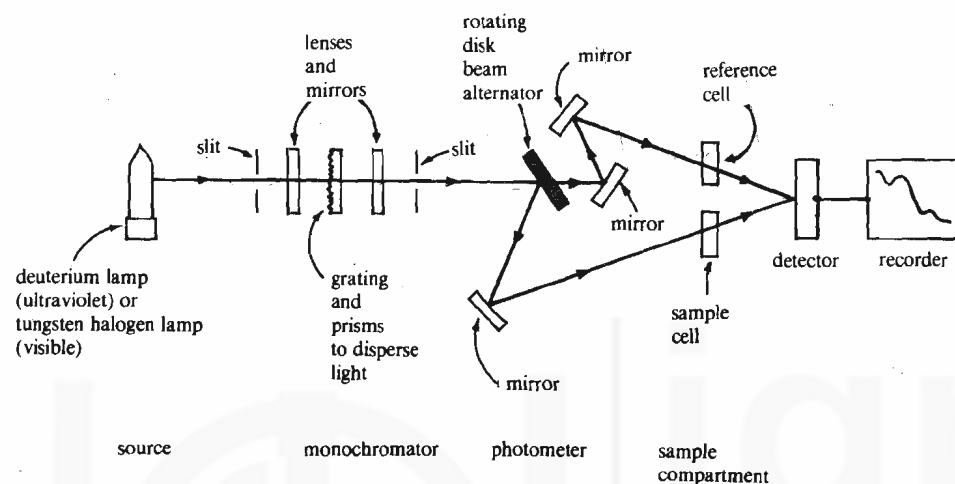

Fig. 4.8 : Schematic diagram of a typical ultraviolet-visible spectrophotometer.

spectrophotometer contains a tungsten filament lamp which gives the radiation having wavelength greater than 375 nm and a deuterium discharge lamp which yields the radiation of wavelengths below this value.

The spectrum is usually recorded using a very dilute solution of the sample. The sample solution is taken in cells which are made of quartz or silica. The cells of different path lengths, i.e., 0.1 cm, 1 cm and 10 cm are commercially available but for most of organic work, cells of 1 cm path length are employed. Two cells, one containing the sample solution and the other containing the pure solvent, are placed at appropriate places in the spectrophotometer. Two beams of equal intensity of uv radiation are passed through these cells. The intensities of the transmitted beams are then compared over the whole range of wavelength of the instrument which gives the absorbance at each wavelength. On most machines, the spectrum is automatically plotted by a recorder as absorbance versus wavelength.

While preparing the sample solution for recording the UV spectrum, the solvent must be so chosen that it should be transparent to the wavelength range being examined. Usually cyclohexane, 95% ethanol and 1,4 dioxane are used as solvents. Cyclohexane can be used for dissolving aromatic compounds particularly the polynuclear aromatic compounds. But when a polar solvent is required 95% ethanol or absolute ethanol is a good choice. Many **spectral grade** solvents are also commercially available.

Absolute ethanol or anhydrous ethanol is a very pure alcohol and is obtained by further drying of the 95% ethanol.

When the spectrum is recorded in different solvents, it may lead to a change in the position or in the intensity of the absorption band. This is known as **solvent effect**. When the shift is towards **longer** wavelength, it is known as **bathochromic shift** or **red shift**. When the shift is towards **shorter** wavelength, it is called **hypsochromic shift** or **blue shift**. Similarly, the increase in absorption intensity is called **hyperchromic effect** and the decrease in absorption intensity is known as **hypochromic effect**. The UV spectral data for various classes of compounds will be discussed in the respective units of this course.

You can now check your understanding about ultraviolet spectroscopy by answering the following SAQ.

## SAQ 2

Identify the chromophore present in the following compounds. Also predict which one of these will have the highest  $\lambda_{\max}$  in uv spectra?

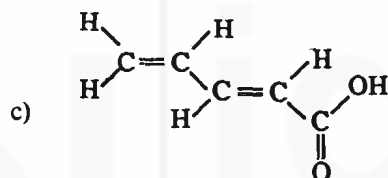
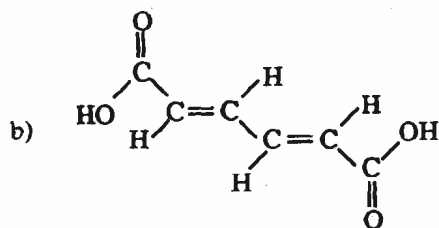
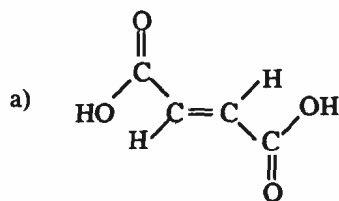

## 4.5 INFRARED SPECTROSCOPY

**Infrared** means beneath the red.

Wavenumber is denoted as  $\bar{\nu}$ .

Many scientists prefer to use the wavenumber convention because it is directly proportional to energy and frequency.

Wavenumber,  $\bar{\nu}$ , is inversely proportional to the wavelength,  $\lambda$ , and the relationship between the two can be expressed as,

$\bar{\nu} = 1/\lambda$  when  $\lambda$  is expressed in centimetres, and

$\bar{\nu} = \frac{10^4}{\lambda}$ , when  $\lambda$  is expressed in micrometres.

The region of wavenumbers lower than  $625 \text{ cm}^{-1}$  is called **far infrared** and that of wavenumbers higher than  $4000 \text{ cm}^{-1}$  is called **near infrared**.

The infrared region of the electromagnetic spectrum lies between the visible and the microwave region. Hence, it corresponds to the range of wavelength from about  $10^{-4}$  to  $10^{-6}$  m. But the portion of infrared spectral region which is most useful for structure determination, lies between  $2.5 \times 10^{-6}$  m and  $16 \times 10^{-6}$  m. The IR spectral data is usually expressed either in terms of **wavelength** of the radiation absorbed in micrometre units or in terms of **wavenumber**. Since one micrometre ( $\mu\text{m}$ ) is equal to  $10^{-6}$  m, the above region of infrared spectrum ranges from 2.5 to 16  $\mu\text{m}$ . As wave number is the number of wavelengths contained in one centimetre, therefore, wavenumbers are expressed in units of reciprocal centimetres ( $\text{cm}^{-1}$ ). Hence, we can calculate the wavenumbers for the region of IR radiation we are interested in, as shown below:

For  $\lambda = 2.5 \times 10^{-6}$  m or  $2.5 \times 10^{-4}$  cm, we get,

$$\text{wave number, } \bar{\nu} = \frac{1}{\lambda} = \frac{1}{2.5 \times 10^{-4}(\text{cm})} = \frac{1}{2.5} \times 10^4 \text{ cm}^{-1} = 4000 \text{ cm}^{-1}$$

Similarly,  $\lambda = 16 \times 10^{-6}$  m or  $16 \times 10^{-4}$  cm yields  $\bar{\nu} = \frac{1}{16 \times 10^{-4}(\text{cm})}$

$$= \frac{1000}{16} \text{ cm}^{-1}$$

$$= 625 \text{ cm}^{-1}.$$

Thus, we will be examining the infrared region between wavenumbers  $625 \text{ cm}^{-1}$  and  $4000 \text{ cm}^{-1}$ . An advantage of using wavenumbers is that they are directly proportional to the energy whereas the wavelength is inversely proportional to energy.



Let us now study the effect of absorption of IR radiation on molecular structure.

Atoms within a molecule are constantly vibrating about their average positions; such motions are referred to as **molecular vibrations**. The molecular vibrations can be of various types. One such vibration which produces changes in bond length is called a **stretching vibration**. The other type that changes bond angles is called a **bending vibration**. Fig. 4.9 shows various kinds of stretching and bending vibrations,

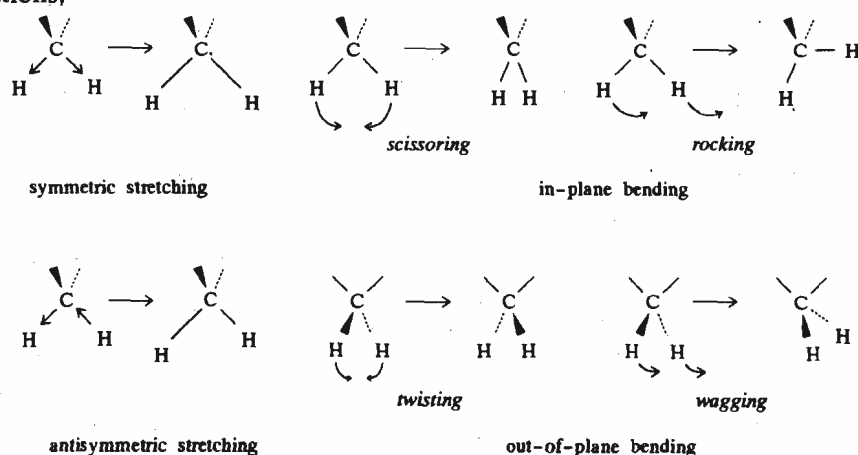

Fig. 4.9 : The stretching and bending vibrations in a molecule.

The absorption of infrared radiation leads to changes in the vibrational states of the molecule. A number of different vibrational states are possible for a molecule. When radiation having energy equal to the energy difference between molecular vibrational energy levels is absorbed, the amplitude of these vibrations increases and the molecule moves from the lower vibrational energy level to the higher vibrational energy level.

Not all molecules absorb the infrared radiation. Generally, the absorption of the infrared radiation, corresponding to a particular vibration, is observed only if the dipole moment of the molecule is different in the two vibrational states. This is because the variation of the dipole moment and a change in the interatomic distance due to vibration, results in an oscillating electric field which can interact with the oscillating electric field of the incident infrared radiation. Hence, a vibrational transition will be **infrared-active** only if it is accompanied by a change in the dipole moment. For example, in case of carbonyl functional group, the stretching vibration leads to an increase in dipole moment. Hence, it is infrared active and the carbonyl group absorbs radiation in the infrared region. On the other hand, vibrational transitions that do not result in a change of the dipole moment are not observed in the infrared spectrum and are said to be **infrared-inactive**. Hence, symmetrical molecules such as  $H_2$ ,  $O_2$  etc., do not absorb the infrared radiation.

The vibrational changes of a diatomic molecule can be visualised using the vibrating spring as a model, as shown in Fig. 4.10.

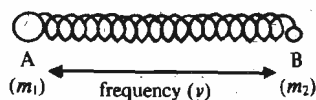
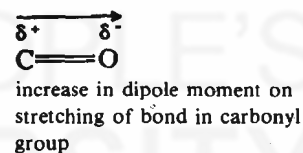
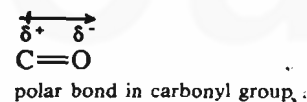

Fig. 4.10 : A vibrating spring : a model for vibrational excitation of a bond in a diatomic molecule.

The two unequal weights on the spring are analogous to two atoms A and B held together by a bond (spring). The vibrational frequency for such a system depends upon the strength of the bond and masses of the atoms involved in the bond formation. The mathematical expression for vibrational frequency, as governed by Hooke's law is given below:

$$\nu = \frac{1}{2\pi_{\text{sec}}} \sqrt{\left( \frac{k}{m_1 m_2 / (m_1 + m_2)} \right)} \quad \dots(4.4)$$

A nonlinear molecule having  $n$  number of atoms has  $3n-6$  possible modes of vibration.



intense absorption

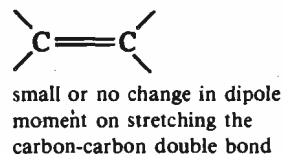
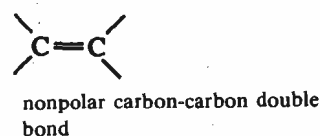

absorption absent or weak

The higher the bond energy, the stronger the bond, and the greater is the force constant. The greater the force constant, the larger is the vibrational frequency.

## Fundamental Concepts

Remember that  
 $E = h\nu = hc/\lambda = hc\bar{\nu}$

You have studied these relationships as Eq. 7.2 in Unit 7, Block 2 of Atoms and Molecules course.

Therefore,  $h\nu = hc\bar{\nu}$  and  
 $\nu = c\bar{\nu}$  or  $\bar{\nu} = \nu/c$

where  $\nu$  is the vibrational frequency,  $k$  is force constant and  $m_1$  and  $m_2$  are the masses of two atoms A and B, respectively.

The quantity  $\frac{m_1 m_2}{(m_1 + m_2)}$  is also known as the reduced mass,  $\mu$ , of the system.

Substituting  $\mu$  for  $m_1 m_2 / (m_1 + m_2)$  in Eq. 4.4 and expressing it in terms of wavenumber,  $\bar{\nu}$ , we get,

$$\bar{\nu} = \frac{\nu}{c} = \frac{1}{2\pi c} \sqrt{\frac{k}{\mu}} \quad \dots(4.5)$$

where  $c$  is the velocity of light.

Since force constant varies with the bond strength, Eq. 4.5 leads us to expect that every individual bond in a molecule will show a specific absorption band in the infrared spectrum. Hence, different functional groups will absorb at different frequencies corresponding to the vibrations typical of that portion of a molecule. Thus, infrared spectral data can be used to identify various functional groups present in the molecule. The characteristic infrared absorption data for some common structural units are listed in Table 4.2. However, a detailed interpretation for the position of infrared absorptions for various classes of compounds will be given in the respective units dealing with them.

Table 4.2 : Characteristic Infrared Absorption Bands.

Bond Type	Stretching, $\text{cm}^{-1}$	Bending, $\text{cm}^{-1}$
C-H alkanes	2960-2850( <i>s</i> )	1470-1350( <i>s</i> )
C-H alkenes	3080-3020( <i>m</i> )	1000-675( <i>s</i> )
C-H aromatic	3100-3000( <i>v</i> )	870-675( <i>v</i> )
C-H aldehyde	2900, 2700( <i>m</i> , 2 bands)	
C-H alkyne	3300( <i>s</i> )	
C $\equiv$ C alkyne	2260-2100( <i>v</i> )	
C $\equiv$ N nitrile	2260-2220( <i>v</i> )	
C=C alkene	1680-1620( <i>v</i> )	
C=C aromatic	1600-1450( <i>v</i> )	
C=O ketone	1725-1705( <i>s</i> )	
C=O aldehyde	1740-1720( <i>s</i> )	
C=O $\alpha$ , $\beta$ -unsaturated ketone	1685-1665( <i>s</i> )	
C=O aryl ketone	1700-1680( <i>s</i> )	
C=O ester	1750-1735( <i>s</i> )	
C=O acid	1725-1700( <i>s</i> )	
C=O amide	1690-1650( <i>s</i> )	
O-H alcohols (not hydrogen bonded)	3650-3590( <i>v</i> )	
O-H alcohols (hydrogen bonded)	3600-3200( <i>s</i> , broad)	1620-1590( <i>v</i> )
O-H acids	3000-2500( <i>s</i> , broad)	1620-1510( <i>s</i> )
N-H amines	3500-3300( <i>m</i> )	
N-H amides	3500-3350( <i>m</i> )	
C-O alcohols, ethers, esters	1300-1000( <i>s</i> )	
C-N amines, alkyl	1220-1020( <i>w</i> )	
C-N amines, aromatic	1360-1250( <i>s</i> )	
NO <sub>2</sub> nitro	1560-1515( <i>s</i> )	
	1385-1345( <i>s</i> )	

*s* = strong absorption  
*m* = medium absorption

*w* = weak absorption  
*v* = variable absorption

Having studied the basic features of infrared spectroscopy, let us now learn how the infrared spectrum of a compound is recorded and how it really looks like.

## 4.5.1 Experimental Aspects of Infrared Spectroscopy

The details of an infrared spectrophotometer used for recording an infrared spectrum are shown in Fig. 4.11.

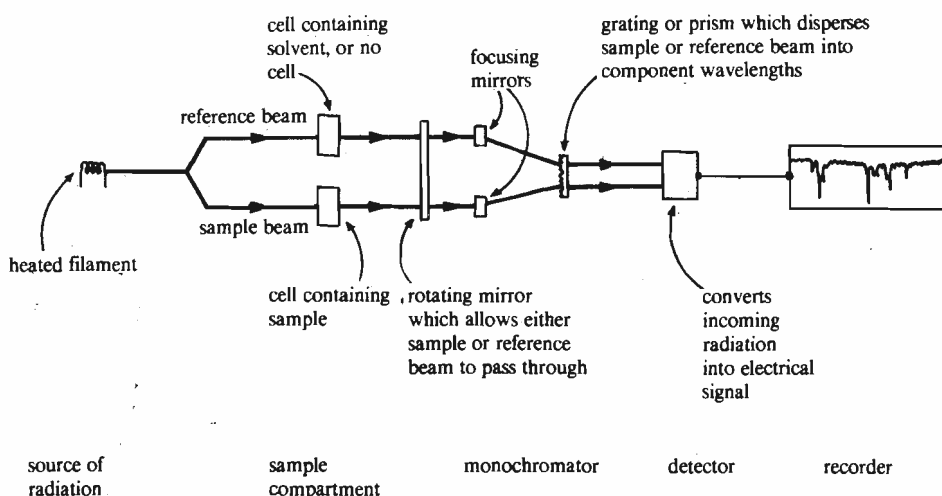

Fig. 4.11 : A schematic diagram of an infrared spectrophotometer.

Infrared radiation can be obtained by electrically heating the rods of the Nernst glower or Globar. The Nernst glower contains the oxides of zirconium, thorium and cerium while the Globar is a small rod of silicon carbide. Similar to the recording of the ultraviolet spectrum, here also the radiation is split into two equal beams, one of which passes through the sample and the other serves as a reference beam. The amount of radiation absorbed by the sample is recorded by the instrument in the form of a plot showing per cent transmittance on its vertical axis against wavenumbers plotted in  $\text{cm}^{-1}$  on the horizontal axis. The transmittance,  $T$ , of a sample is given by the ratio  $I/I_0$  and is the per cent of the incident radiation (i.e., radiation falling on the sample) that is transmitted to the detector. Clearly when all the radiation has been absorbed by the sample, the transmittance is 0%. On the contrary, 100% transmittance means no absorption of the radiation. Hence, the absorptions in the infrared spectrum are registered as downward deflections or the upside-down peaks. For example, the infrared spectrum of nonane as shown in Fig. 4.12 has absorptions at 2925, 1467, 1378 and 722  $\text{cm}^{-1}$ .

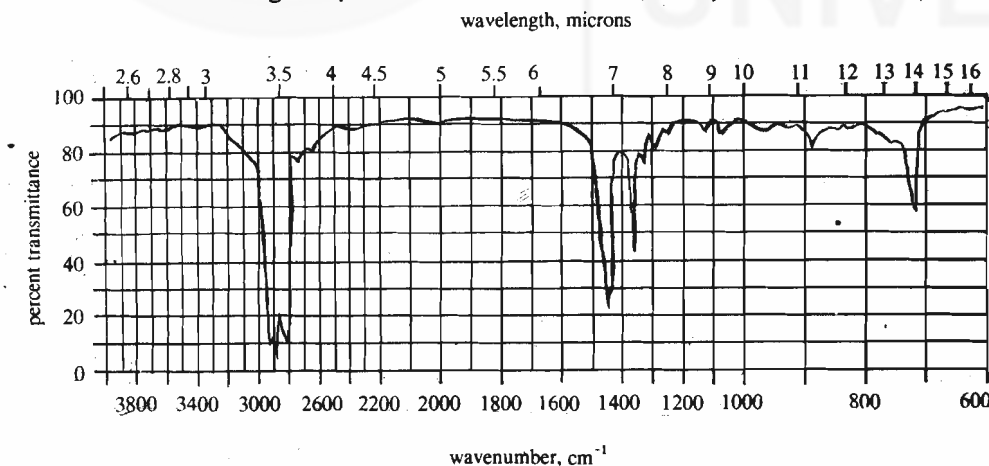
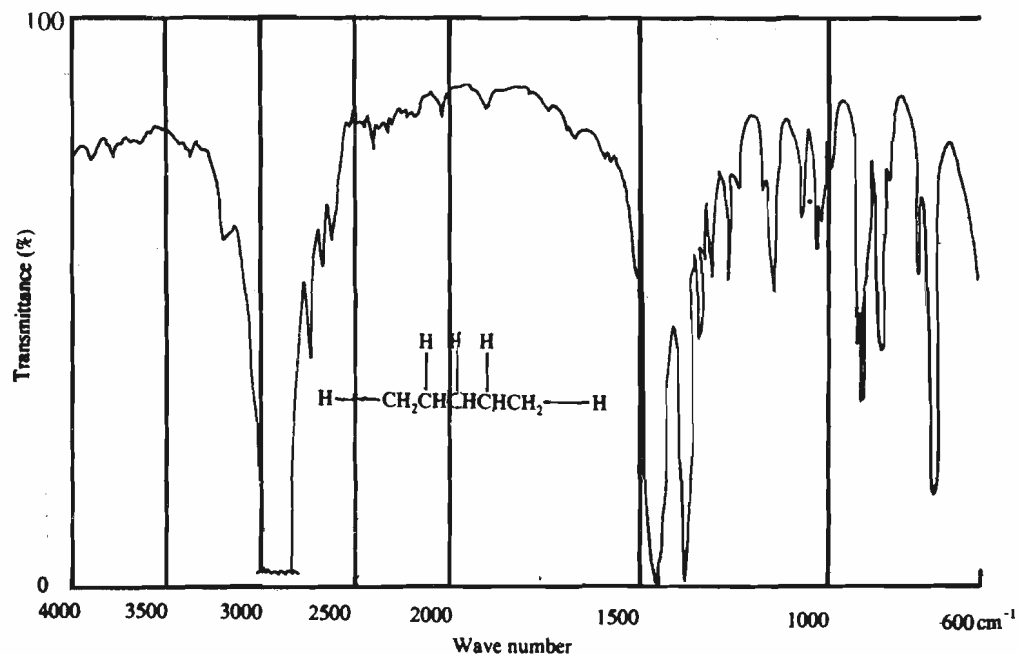

Fig. 4.12 : Infrared spectrum of nonane.

The region of infrared spectrum between 675  $\text{cm}^{-1}$  and 1250  $\text{cm}^{-1}$  is usually referred to as **fingerprint** region. This region shows absorptions which are quite characteristic of a particular molecule. Thus, this region is extremely useful in determining whether the given samples are identical or not. For example, the comparison of the infrared spectra for pentane and hexane (Fig. 4.13) shows that the pattern in the fingerprint region is quite different for the two compounds.





(c)

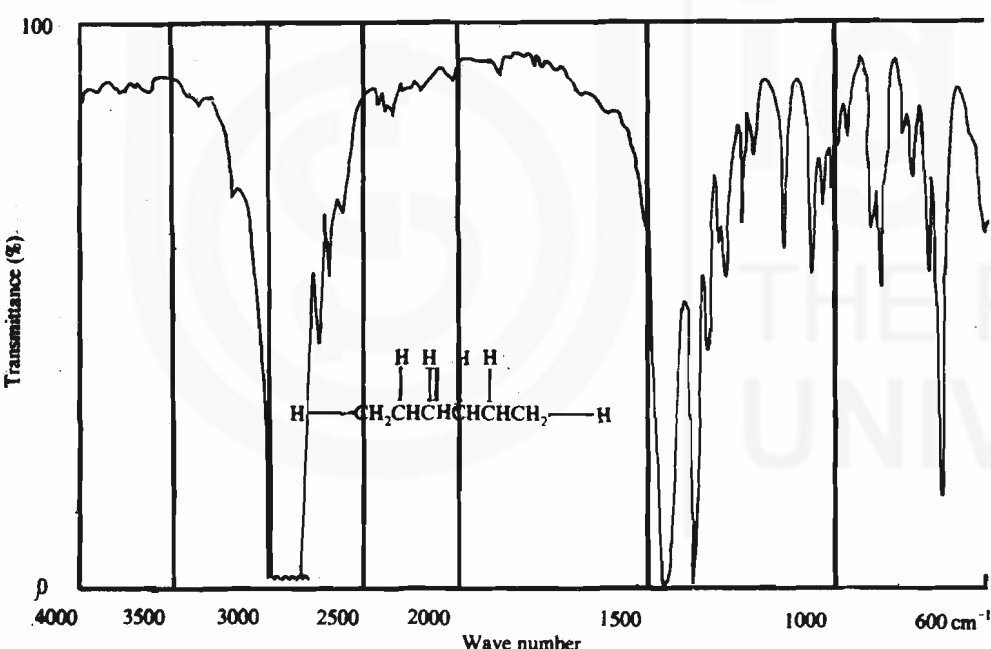

(d)

Fig. 4.13 : (c) IR spectrum of a sample of pentane at higher recorder sensitivity. Note that the fingerprint pattern is different from the pattern in the analogous spectrum of hexane. (d) IR spectrum of a sample of hexane at higher recorder sensitivity.

The infrared spectrum can be recorded on samples in solid, liquid, gaseous or solution state. For solid samples, generally, a Nujol mull or KBr disc is prepared. In case of liquid samples, a thin film of liquid is used between two infrared-transparent windows made of NaCl flats. For gases or low-boiling liquids, the spectrum can be obtained by using gas cells. The spectrum of a sample in the solution state is recorded by making 1-5% solution of the compound in solvents such as carbon tetrachloride, carbon disulphide or chloroform. These solvents have relatively few IR absorptions. Let us now end our discussion about IR spectroscopy. You will study the IR spectra of various compounds in the further blocks of this course.

Nujol is a high boiling petroleum oil.

KBr discs are prepared by grinding the sample (0.1-2% by weight) with dry KBr and processing it into a disc in a die.

KBr and NaCl do not absorb IR radiation.

Before proceeding to the next section which describes another type of spectroscopy, called nuclear magnetic resonance spectroscopy, answer the following SAQ.

## SAQ 3

Which of the following vibrations will be infrared active and which would be infrared inactive?

a) C=O stretch in  $(\text{CH}_3)_2\text{C}=\text{O}$

.....

b)  $\text{C}\equiv\text{C}$  stretch in  $\text{C}_2\text{H}_5-\text{C}\equiv\text{C}-\text{C}_2\text{H}_5$

.....

d)  $\text{C}-\text{Cl}$  stretch in  $\begin{array}{c} \text{CH}_3 \\ \backslash \\ \text{CH}_3-\text{C}-\text{Cl} \\ / \\ \text{CH}_3 \end{array}$

.....

d)  $\text{C}=\text{C}$  stretch in  $\begin{array}{c} \text{CH}_3 \\ \backslash \\ \text{C}=\text{CH}_2 \\ / \\ \text{CH}_3 \end{array}$

.....

## 4.6 NUCLEAR MAGNETIC RESONANCE SPECTROSCOPY

The physical significance of nuclear spin is that the nucleus acts like a tiny magnet and tends to become aligned in a magnetic field.

Nuclear magnetic resonance (nmr) spectroscopy is one of the most useful methods for structure elucidation. It was first observed in 1946 and is based on the magnetic properties exhibited by certain nuclei. Many atomic nuclei behave as if they are spinning and hence are said to have **nuclear spin**. The circulation or spinning of the nuclear charge generates a magnetic dipole whose magnitude is given by the nuclear magnetic moment. These magnetic properties occur in nuclei which have

- odd atomic and odd mass numbers; examples being  $^1_1\text{H}$ ,  $^{15}_7\text{N}$ ,  $^{19}_9\text{F}$  and  $^{31}_{15}\text{P}$ ,
- odd atomic number and even mass number; for example,  $^2_1\text{H}$  and  $^{14}_7\text{N}$ , and
- even atomic number and odd mass number as in  $^{13}_6\text{C}$ .

Similar to the electron spin, the nuclear spin is given by nuclear spin quantum number,  $I$ , which can have values 0, 1/2, 1, 3/2, 2, etc. The spin quantum number,  $I$ , has contributions both from the protons and the neutrons present in the nucleus. If the sum of the protons and neutrons is even then,  $I$  has zero or integral values, i.e.,  $I = 0, 1, 2, \dots$  etc. In case this sum is odd, then  $I$  has half integral values, i.e., 1/2, 3/2, 5/2 etc. But, when the number of both the protons and the neutrons is even, then,  $I$  is zero. Hence, the nuclei  $^{12}_6\text{C}$  or  $^{16}_8\text{O}$  do not show any resultant spin or magnetic moment and are, therefore, nonmagnetic. On the other hand, the nuclei,  $^1_1\text{H}$ ,  $^{19}_9\text{F}$ ,  $^{13}_6\text{C}$ ,  $^{15}_7\text{N}$  and  $^{31}_{15}\text{P}$  have  $I = 1/2$  and the nuclei  $^{14}_7\text{N}$  and  $^2_1\text{H}$  have  $I = 1$ . The number of orientations which a nucleus may assume in the magnetic field is given by  $2I + 1$ . Hence, for the hydrogen nucleus, the number of possible orientations is  $2 \times 1/2 + 1 = 2$ . These two spin states are characterised by the values  $+1/2$  and  $-1/2$  for the spin quantum number,  $I$ , in case of the hydrogen nucleus. Fig. 4.14 shows the two spin states of a proton.

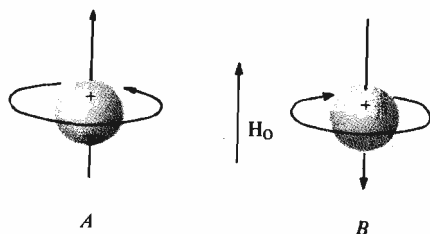

Fig. 4.14 : The nuclear spin states of a proton. Spin state A, in which the nuclear magnetic moment is parallel to the applied field  $H_0$ , is of lower energy than spin state B, in which the nuclear magnetic moment is antiparallel to the applied field.

These two spin states have the same energy in the absence of the magnetic field. However, a difference in energy between these spin states can be created by applying the magnetic field. This is illustrated in Fig. 4.15.

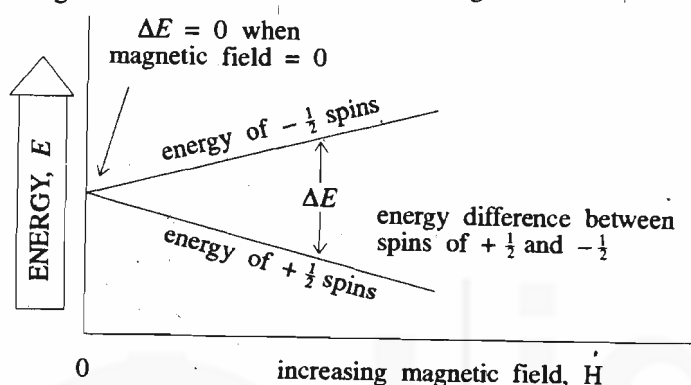

Fig. 4.15 : Effect of magnetic field on the energy difference of two nuclear spin states.

This energy difference is then detected by absorption of radiation of appropriate energy which corresponds to the radiofrequency region of the electromagnetic spectrum. The absorption of energy in this region causes these nuclei to invert or 'flip' their spins which involves a change from a lower energy state having  $+1/2$  spin to higher energy state having  $-1/2$  spin. When the energy of the source matches with the energy difference between the nuclear spin states, then the nuclei are said to be in **resonance** with the electromagnetic radiation.

The energy difference between the two spin states,  $\Delta E$ , can be quantitatively expressed as:

$$\Delta E = \frac{h\gamma}{2\pi} H \quad \dots(4.6)$$

Where  $h$  is Planck's constant,  $H$  is the magnetic field strength at the nucleus and  $\gamma$  is the magnetogyric ratio. Magnets varying in field strengths ranging from  $1.4 \tau$  to  $7.1 \tau$  are employed in various instruments. The corresponding frequency values needed to observe resonance lie between 60 MHz and 300 MHz. For hydrogen nuclei, when a magnetic field of  $1.4 \tau$  is applied, a radiation of frequency of 60 MHz is required. Similarly, for the magnetic field of  $2.1 \tau$ , a radiation of frequency 90 MHz is required. Since, almost all organic compounds contain hydrogens, the study of nmr spectroscopy of hydrogen nucleus is very useful to an organic chemist.

Before taking such an assignment, let us now learn about the instrumentation and experimental aspects of nmr spectroscopy.

#### 4.6.1 How to Obtain an NMR Spectrum?

Fig. 4.16 shows the schematic diagram of a typical nuclear magnetic resonance spectrometer. The sample to be studied is usually dissolved in a suitable solvent which itself does not absorb in the nmr range under investigation. For proton nmr, usually carbon tetrachloride or deuterated solvents such as  $\text{CDCl}_3$  (deuteriochloroform),  $\text{CD}_3\text{COCD}_3$  (hexadeuterioacetone) or  $\text{C}_6\text{D}_6$  (hexadeuteriobenzene) are used. This solution is taken in an nmr sample tube (a cylindrical glass tube of 18 cm length and 5 mm diameter) and is placed between

Do not confuse this usage of the term *resonance* with the one which you will be studying in the next unit.

Magnetogyric ratio is the ratio of the angular momentum (due to rotating nuclear mass) and the magnetic moment (arising from the rotating nuclear charge). This ratio has a characteristic and different value for each nucleus.

The higher the applied field, the greater will be the energy difference between the two spin states of the nucleus. Therefore, the larger will be frequency of the radiation absorbed by the nuclei and hence larger will be the separation between the absorption signals leading to a higher resolution and more clear spectrum.

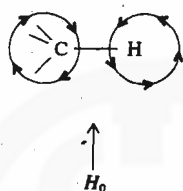
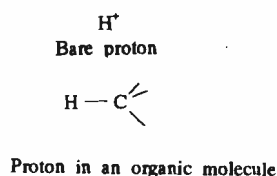

The induced magnetic field of the electrons in the carbon-hydrogen bond opposes the external magnetic field. The resultant magnetic field experienced by the proton is slightly less than  $H_0$ .

**Chemically equivalent** protons are those protons which are in exactly same environment. Therefore, they react exactly in the same manner with the chemical reagents. There are two sets of chemically equivalent protons in butane which are shown below as a and b.

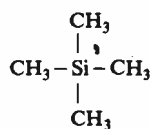
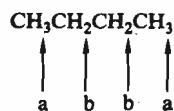

TMS

(Tetramethylsilane)

TMS is added to the sample solution as an internal standard.

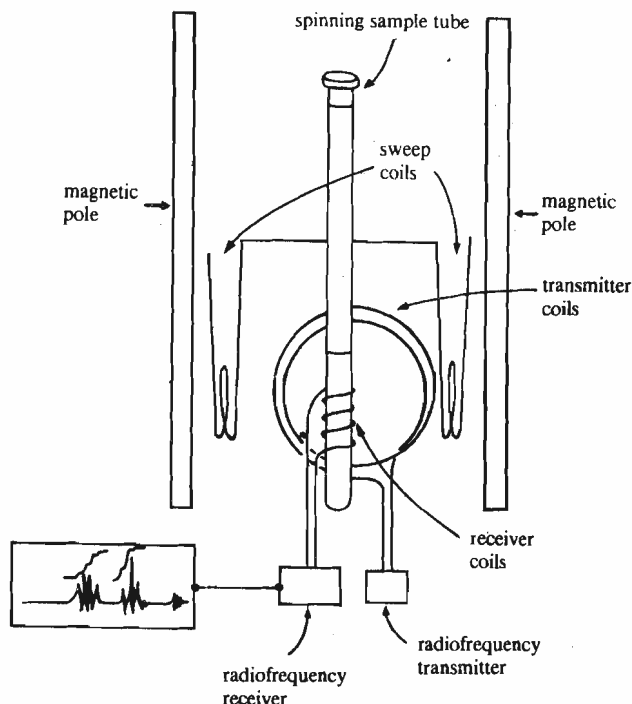

Fig. 4.16 : A schematic representation of the NMR spectrometer.

the poles of the magnet (permanent or electromagnet). The sample is surrounded by a radiofrequency source which irradiates it. Spectrometers using permanent magnets of fixed field strength involve a continuous variation of frequency of the source. When the energy of the source matches with the energy difference between the nuclear spin states, i.e., when the two are said to be in resonance with each other, then the frequency of the electromagnetic radiation which corresponds to this energy, is absorbed. The absorption of energy is detected by a radiofrequency receiver and is shown as a peak in the nmr spectrum.

Nuclear magnetic resonance spectrometers which use electromagnets operate in a complementary manner. In these instruments, the frequency of the source is maintained at a constant value and the magnetic field strength is varied until the energy gap between the spin states matches with that of the source.

Let us now focus our attention on the proton nmr spectrum.

### 4.6.2 Interpretation of Proton NMR Spectrum

Till now, we discussed the two different spin states of a proton. But what is the actual situation in a molecule? In organic molecules, the hydrogen atom is bonded to another atom by a covalent bond. When an external magnetic field is applied, the electrons forming the covalent bond produce an induced magnetic field which opposes the applied magnetic field. Hence, the magnetic field 'felt' by the proton is less than the applied magnetic field. In other words, this hydrogen nucleus is said to be **shielded** by its electron cloud. The degree of shielding depends on the amount of electron density surrounding the nucleus. Hence, the increase in electron density around a proton results in its shielding while its decrease causes the **deshielding**. If the spectrum is recorded by keeping the radiofrequency constant and varying the magnetic field, then for a shielded proton, higher magnetic field will be required to overcome the shielding effect. The protons in different electronic environments experience different amounts of shielding and hence will require different magnetic field strengths for their spin flipping. Thus, unique nmr signals will be observed for chemically different protons in a molecule. But chemically equivalent protons will appear at the same position in the nmr spectrum. The difference in the absorption position of a particular proton from the absorption position of a reference proton is called the **chemical shift** of that particular proton. Generally, the chemical shifts are recorded using the tetramethylsilane (TMS) as the reference compound. The signal due to the hydrogens of the methyl groups of TMS is set as zero while recording the nmr spectrum.



Alternatively, when the spectrum is recorded at constant magnetic field by varying the frequency, then the higher the shielding, the lower will be effective magnetic field experienced by the proton and the lower will be the frequency required to reach the resonance condition.

Since the chemical shift values vary with the radiofrequency and magnetic field used in the instrument, a scale independent of the frequency or field strength applied is required to denote the chemical shift values. One such scale is  $\delta$  (delta) scale and is defined by the ratio of chemical shift to the operating frequency of the instrument. Since the resulting number is small, it is multiplied by  $10^6$  so that it is convenient to handle. Hence,  $\delta$  values are expressed in terms of parts per million (ppm). Using  $\delta$  scale, chemical shifts are recorded downfield (i.e., to the left) from TMS signal which is set at zero delta value. This is shown below in Fig. 4.17. You can see in this figure that the  $\delta$  values increase from right to left. Most of the protons in organic compounds appear in the range of  $\delta$  between 0-10 ppm.

$$\delta = \frac{\nu_{\text{sample}} - \nu_{\text{TMS}}}{\nu_{\text{used in instrument}}}$$

Another scale which is called tau ( $\tau$ ) scale is also used to represent the NMR signals. The  $\tau$  scale is related to  $\delta$  scale by the following expression.

$$\tau = 10 - \delta \quad \dots(4.7)$$

However, the  $\delta$  scale is internationally preferred and we will also report the chemical shift in terms of  $\delta$  values.

The nmr spectrum of ethanol is shown in Fig. 4.17. Using this spectrum as an example, let us now learn how the nmr spectrum of a compound can be correlated with its molecular structure.

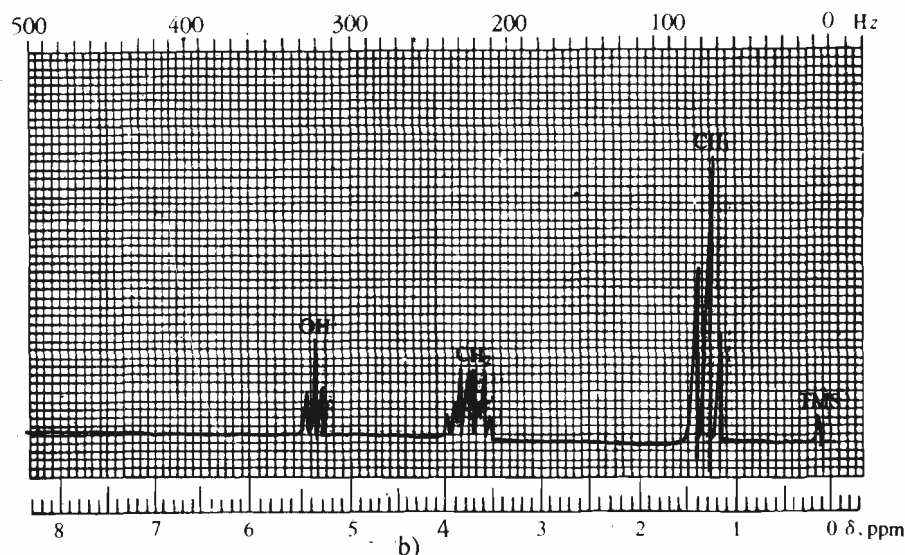
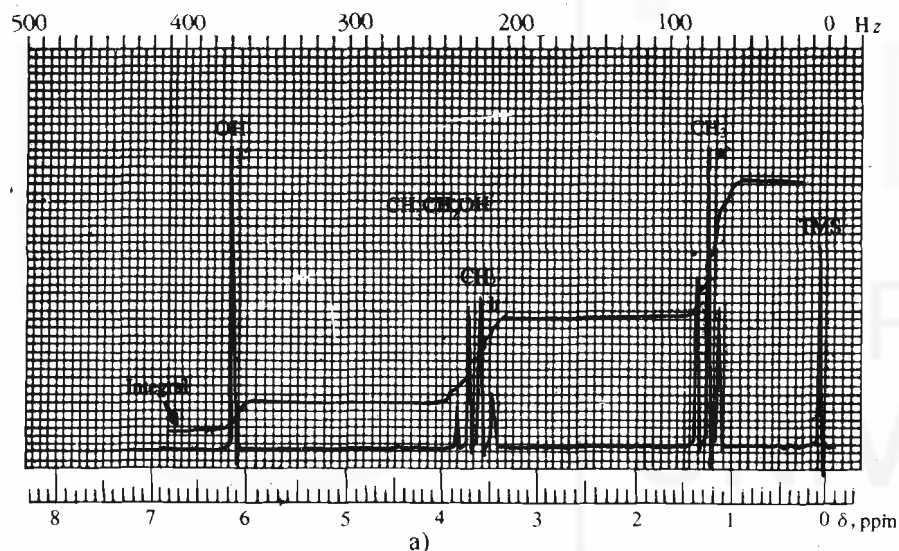
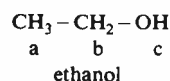

Fig. 4.17 : NMR spectrum of ethanol at 60 MHz : a) Commercial sample of ethanol and b) High resolution nmr spectrum of anhydrous sample of ethanol.



No. of peaks in the nmr signal	Name for peak pattern	Abbreviation
1	singlet	<i>s</i>
2	doublet	<i>d</i>
3	triplet	<i>t</i>
4	quartet	<i>q</i>
5	quintet	<i>quin</i>
6	sextet	<i>sex</i>
7	septet	<i>sep</i>

Although the Fig. 4.17 shows that the chart paper on which the spectrum is recorded is calibrated both in parts per million (ppm, at the bottom) and Hertz (at the top), but you need not worry about the calibration at the top. The chemically nonequivalent hydrogens in a molecule have different chemical shift values and hence will appear at the different positions in the nmr spectrum; therefore, the presence of three sets of signals in the nmr spectrum of ethanol indicates the presence of three sets of non-equivalent protons. These are shown by a, b, c in the spectrum and structural formula of ethanol. Since the  $-\text{CH}_2-$  group is linked to an  $-\text{OH}$  group, its hydrogen atoms are more deshielded as compared to those of the  $-\text{CH}_3$  group. Therefore, the signal for  $-\text{CH}_2-$  hydrogen atoms appear more downfield as compared to that of the  $-\text{CH}_3$  group.

In Fig. 4.17, you must have also noticed the different intensities and patterns of the signals corresponding to the three sets of protons. The peak intensities are given by the total area under the peak which is determined by the mathematical integration of the peak. The nmr spectrometers are equipped with an integrating device which displays the integrals on each peak of the spectrum. The height of each integral is proportional to the area under the peak and is also proportional to the number of protons responsible for the peak. You can check that in the spectrum of ethanol, the heights of integrals for the peaks for  $\text{CH}_3-$ ,  $\text{CH}_2-$  and  $-\text{OH}$  units are in the ratio 3:2:1 which is the ratio of number of hydrogen atoms attached to these units. The pattern of signals observed in Fig. 4.17(a) shows that the signal for the  $-\text{OH}$  proton appears as a single sharp peak which is called a **singlet**. But the signal for  $-\text{CH}_3$  protons appears as a packet of three peaks which is called a **triplet**. Similarly, the signal for the  $-\text{CH}_2-$  protons is called a **quartet** (a set of four peaks). This splitting of signals of chemically equivalent protons into doublets, triplets or quartets occurs due to the effect of one set of protons on the nmr signal of its neighbouring protons. Hence, the number of lines in the splitting pattern of a given set of chemically equivalent protons depends on the number of adjacent protons. This number can be determined using the  $n+1$  rule which says that if  $n$  equivalent protons are adjacent to a set of equivalent protons, the signal for these equivalent protons will be split into  $n+1$  lines. In accordance with this rule, the signal for  $-\text{CH}_3$  group of ethanol is split into three peaks (a **triplet**) because it has two protons adjacent to it. What about the signal for  $-\text{CH}_2-$  protons? The  $-\text{CH}_2-$  group has three hydrogen atoms of  $-\text{CH}_3$  group and one hydrogen atom of the  $-\text{OH}$  group adjacent to it; hence, its signal is split by both the sets of hydrogens. The three hydrogens of the  $-\text{CH}_3$  group split the  $-\text{CH}_2-$  signal into a **quartet** ( $3+1$ ); each of the four peaks of this quartet are further split due to hydrogen of the  $-\text{OH}$  group into two peaks giving rise to an eight line pattern for the  $-\text{CH}_2-$  signal.

The splitting of the signal of  $-\text{OH}$  proton is due to the two adjacent protons of the  $-\text{CH}_2-$  group and hence it must be a triplet. Such a splitting is absent in the nmr spectrum of an ordinary commercial sample of ethanol. This is because the ordinary commercial sample of ethanol contains a trace of moisture which results in a **chemical exchange** of protons between the alcohol and water (or alcohol) molecules as shown below:

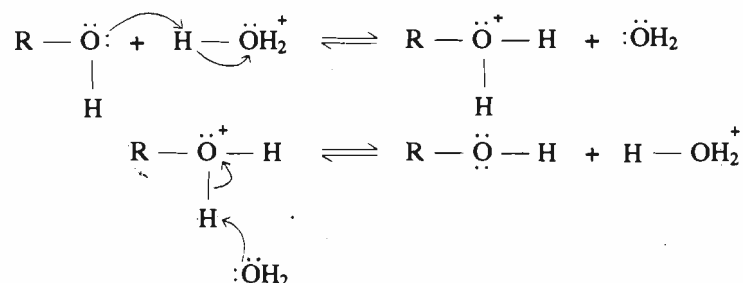

The spacing between the adjacent peaks of a splitting pattern, measured in Hz, is called the coupling constant and is denoted by  $J$ .

Two coupled protons have the same  $J$  value.

The presence of water, acid or base enhances the **chemical exchange**. Since, the chemical exchange is quite fast, the hydrogens of the  $-\text{OH}$  group do not spend enough time on a given molecule for the effective splitting to be recorded. Hence, no splitting due to  $-\text{OH}$  for such samples is obtained and the spectrum is obtained as shown in Fig. 4.17(a) which shows a singlet for  $-\text{OH}$  group, i.e., no splitting, and a quartet for  $-\text{CH}_2-$  protons due to splitting only from methyl hydrogens. But such a splitting is observed in the nmr spectrum of pure anhydrous ethanol, as shown in Fig. 4.17(b). Hence, you can conclude that the nmr spectrum of a

compound can give important information about its structure. You will further appreciate the importance of nmr spectroscopy when you will study the nmr spectra of various compounds in the later units of this course.

At this stage, you have enough understanding of nmr spectroscopy to answer the following SAQ.

**SAQ 4**

Label the chemically equivalent protons in the following compounds by the letters a, b and c.

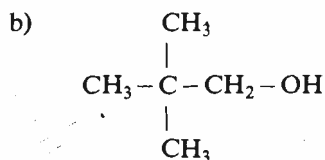
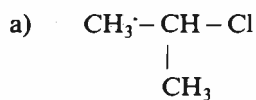

## 4.7 MASS SPECTROMETRY

In contrast to the spectroscopic techniques discussed before, mass spectrometry does not involve the absorption of electromagnetic radiation. But, it involves the bombardment of the molecule with high energy electrons (i.e., having energy of the order  $6700 \text{ kJ mol}^{-1}$  or more). This energy is greater than the bond energies of chemical bonds and is hence sufficient to knock an electron out of the molecule, giving rise to a radical cation. For example, if methane is bombarded in this way, it loses an electron from one of the C-H bonds, as shown below.

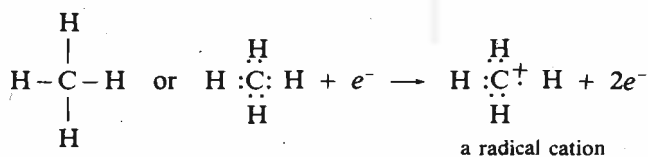

This radical cation which is formed from a molecule just by the loss of an electron is also called **molecular ion** and is commonly denoted as  $\text{M}^+$  ion. This molecular ion can further undergo a series of **fragmentation reactions** to give other radical cations, carbocations and neutral molecules. This is illustrated below for the above radical cation.

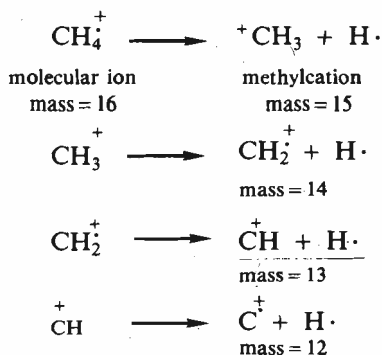

A radical cation is named so because it is both a radical and a cation and is denoted by +

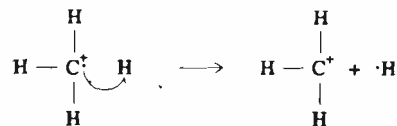

Note that a fishhook arrow is used to show the electron movement.

Another possibility is the formation of a methyl radical and a proton, as shown below:

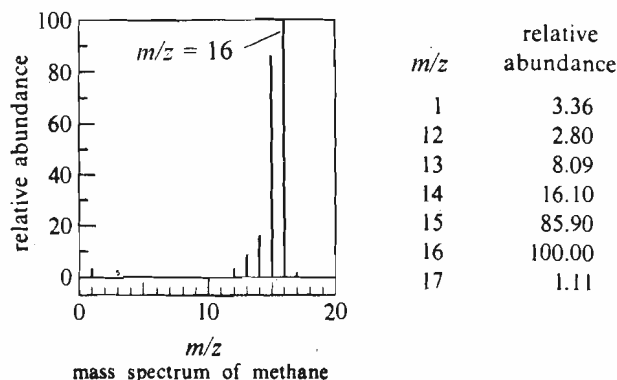
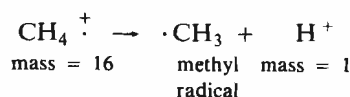

The radical cations so obtained are charged particles and hence can be accelerated by an electric field. These are then directed to an analyser surrounded by a magnet, see Fig. 4.18. This magnet deflects the ions from their original trajectory into a circular path whose radius depends on their mass to charge ( $m/z$ ) ratio and the strength of the magnetic field. Hence, the ions having small  $m/z$  value are deflected more than those having larger  $m/z$ . By varying either the field strength or the degree of acceleration, ions of a particular  $m/z$  value can be counted by the detector of the spectrometer. Scanning of all  $m/z$  values gives the distribution of positive ions as the **mass spectrum**. The mass spectrum of a compound shows the relative amount of each ion (called the **relative abundance**) plotted on the vertical axis versus their  $m/z$  values plotted on the horizontal axis. Remember that only the ions are detected by mass spectrometer and not the neutral molecules or radicals.

Most ions obtained in the mass spectrometer have a single positive charge; hence, their separation is essentially done according to their mass.

Sophisticated mass spectrometers known as high resolution mass spectrometers can resolve ions which are different in their mass by only a few thousandths of a mass unit. For example  $\text{CO}^+$  ( $m/z = 27.9940$ ),  $\text{N}_2^+$  ( $m/z = 28.0062$ ) and  $\text{C}_2\text{H}_4^+$  ( $m/z = 28.0312$ ) are distinguishable using high resolution mass spectrometer.

A very small amount of sample, i.e., about  $10^{-6}\text{g}$  is required for recording the mass spectrum.

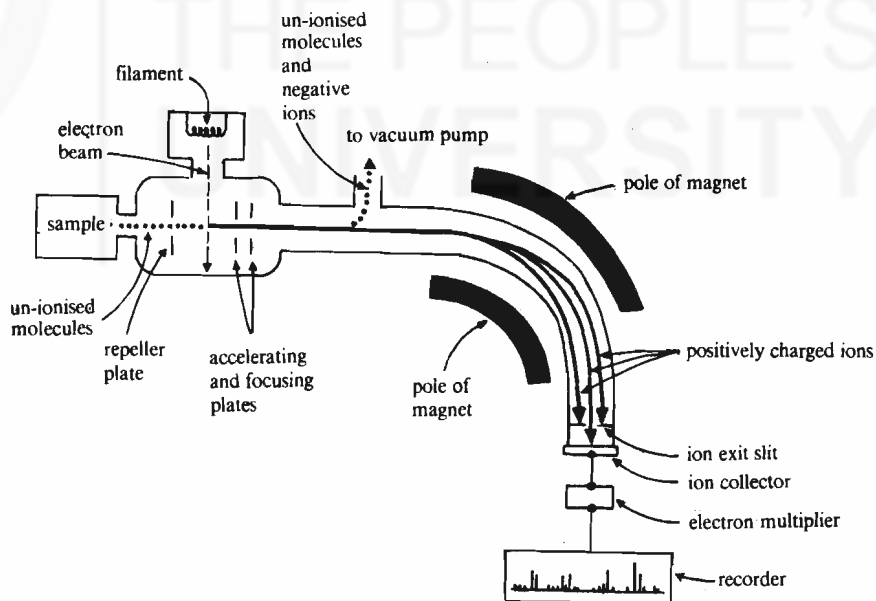

Fig. 4.18 : Schematic diagram of a typical mass spectrometer.

The mass spectrum of a compound can be used to determine its molecular weight by identifying the molecular ion peak in the spectrum. In addition to this, analysis of the fragment ions yields important information regarding the structure of the compound. Let us now analyse the mass spectrum of 2,2-dimethylpropane shown in Fig. 4.19. You can see a small molecular ion peak at  $m/z$  72 in the spectrum.

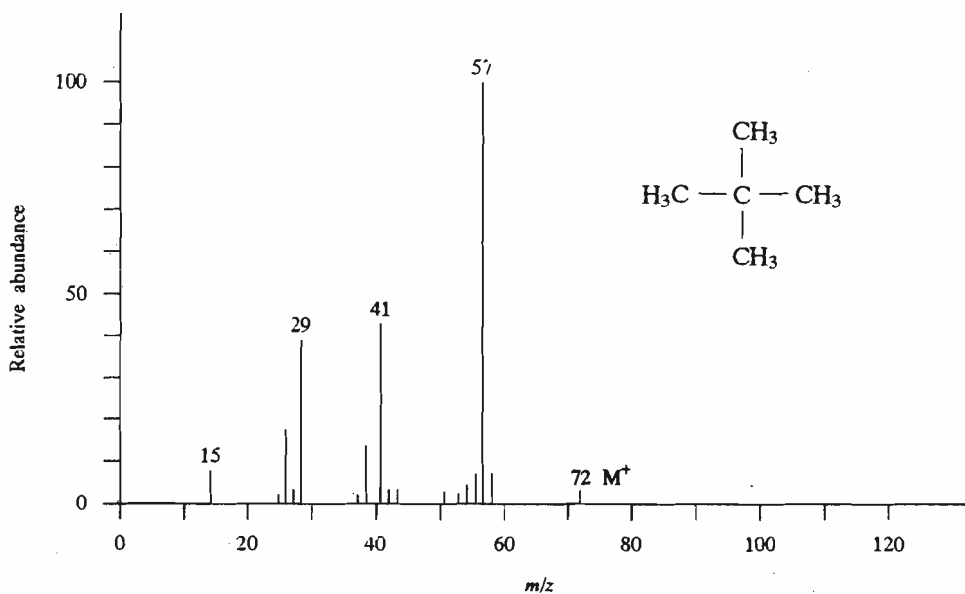
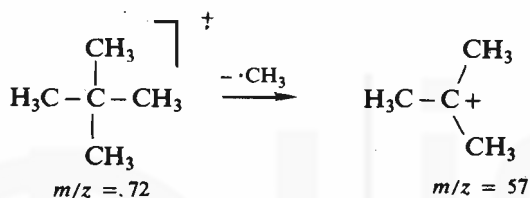
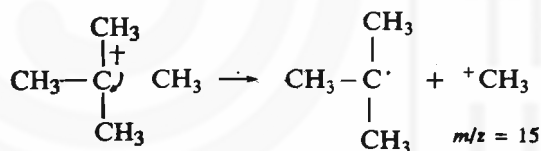

Fig. 4.19 : The mass spectrum of 2,2-dimethylpropane.

This molecular ion can further lose a  $\cdot\text{CH}_3$  radical to yield another fragment having  $m/z$  57, as shown below.



In this case, this fragment is the most abundant one and hence is called the **base peak**. The base peak is assigned the relative abundance of 100%. The abundance of the other ions is shown relative to this peak.



The peak having  $m/z = 15$  is also observed in the spectrum but is less intense. The other prominent peaks observed are at  $m/z$  41 and 29. This molecule cannot directly yield fragments such as  $\text{C}_3\text{H}_5^+$  and  $\text{C}_2\text{H}_5^+$ , respectively, corresponding to the above  $m/z$  values. But, fragment ions of this type can result due to complex structural reorganisations which we will not discuss here.

In many compounds, the mass spectrum shows the presence of small  $M+1$  and  $M+2$  peaks. These peaks arise from the presence of isotopes of carbon, hydrogen, oxygen or halogens (like chlorine). For example, presence of  $^{13}\text{C}$  in a compound will show an  $(M+1)^+$  peak in its mass spectrum. The natural abundance of  $^{13}\text{C}$  is 1.08% as compared to that of  $^{12}\text{C}$ . But, the natural abundance of the heavier isotopes of chlorine ( $^{37}\text{Cl}$ ) is 32.5% as compared to  $^{35}\text{Cl}$ . Hence, a compound containing one chlorine atom will exhibit an  $M+2$  peak which is of about one-third intensity as compared to the  $M^+$  peak. However, the mass spectrum of chloroform having three chlorine atoms, will show  $M+2$ ,  $M+4$  and  $M+6$  peaks depending upon the combination of isotopes of the chlorine present.

Thousands of compounds of known structure have been examined by mass spectrometry and the fragmentation patterns characteristic of various classes of compounds have been studied. Thus, a knowledge of these fragmentation patterns helps in identification of compounds.

Let us now sum up the contents of this unit.

## 4.8 SUMMARY

In this unit, you learnt that

- The physical properties of a compound such as its melting point, boiling point and solubility depend upon the intermolecular forces present between the molecules. The three types of intermolecular forces are:
  - i) dipole-dipole interactions
  - ii) London forces, and
  - iii) hydrogen bonding.
- The melting points increase with increasing molecular weight and molecular symmetry.
- The boiling point of a compound depends upon the intermolecular forces of attraction. An increase in molecular size increases London forces and hence it leads to an increase in the boiling point. On the other hand, branching reduces the total surface area leading to decrease in the boiling point.
- Intermolecular hydrogen bonding increases the boiling point and is also responsible for the higher water solubility of a compound.
- Absorption of energy from different regions of electromagnetic radiation leads to different kinds of spectroscopy.
- The absorption of ultraviolet radiation results in electronic excitations in the molecule. The wavelength of absorption increases with increasing conjugation and hence highly conjugated compounds are coloured.
- Infrared spectroscopy deals with the absorption of infrared radiation corresponding to characteristic molecular vibrations. The infrared spectrum provides information about various structural units and the functional groups present in the molecule.
- The three elements of NMR spectrum are **chemical shift** which provides information about the chemical environment of the particular nucleus, the **integral** which tells the relative number of the nuclei being observed; and the **splitting** which gives information about the number of nuclei on the adjacent atoms.
- The mass spectrum of a compound is a record of the  $m/z$  values of various fragments versus their relative abundance.

## 4.9 TERMINAL QUESTIONS

1. Match the following compounds with their melting points.  
**Compounds:** 2,2,3,3-tetramethylbutane and octane  
**m.p. :** 374 K and 216 K
2. Arrange the following molecules in the increasing order of their boiling points
  - a) 2-Methylhexane
  - b) Heptane
  - c) 2,2-Dimethylpentane
  - d) 2,2,3-Trimethylbutane
3. Given below are the C=C stretching absorptions for some compounds. Which one of these compounds has the strongest double bond? Why?

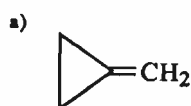

1781  $\text{cm}^{-1}$

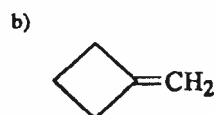

1672  $\text{cm}^{-1}$

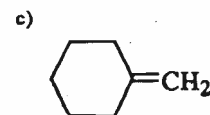

1650  $\text{cm}^{-1}$

4. Can you differentiate between the compounds of each of the following pairs. Name the spectroscopic technique you will use and give reason in support of your answer.

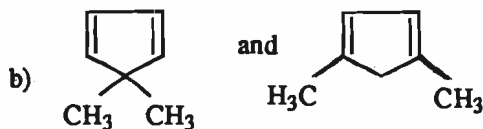
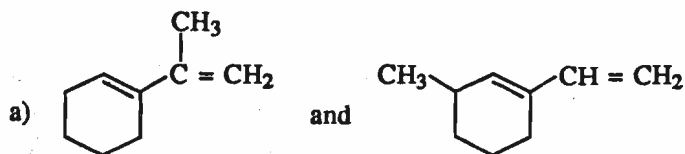

5. Predict the number of signals and their splitting pattern in the nmr spectra of the following compounds:
- $\text{CH}_3-\text{CH}_2-\text{Br}$
  - $\text{CH}_3-\text{CHI}-\text{CH}_3$
6. Two unknown compounds (a) and (b) containing C, H and O showed the molecular ion peaks at  $m/z$  (a) 46 and (b) 30. Give possible structures to these compounds.

## 4.10 ANSWERS

### Self Assessment Questions

- False
  - False
  - True
  - False
  - True
  - True
- a)

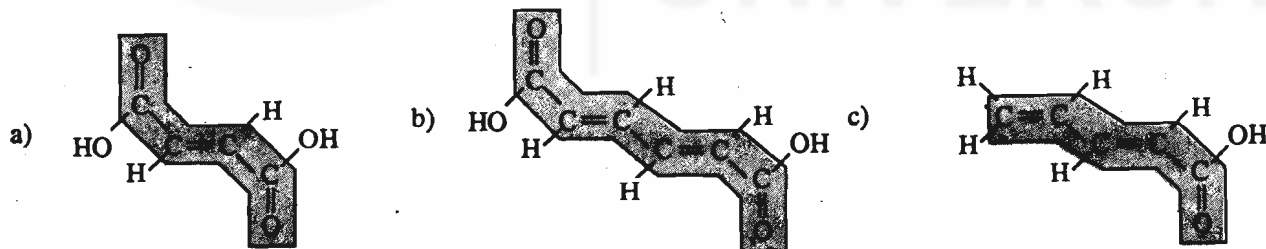

b) will have longest wavelength of absorption.

3. a) active b) inactive c) active d) active.

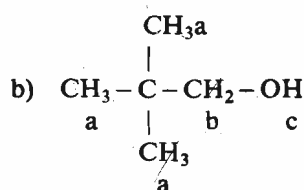
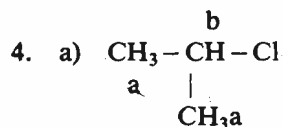

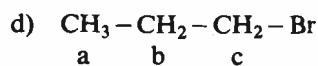
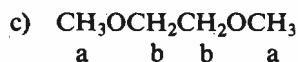

## Terminal Questions

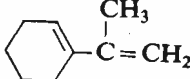
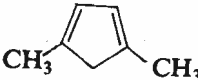
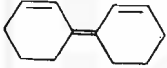
- 2,2,3,3-Tetramethylbutane, 374 K.  
Octane, 216 K.
- The boiling points are in the following order.  
(d) < (c) < (a) < (b).
- The double bond in  molecule is the strongest one because it has the largest value of C=C stretching absorption.
- Yes, the two compounds in each of the pairs can be differentiated. The UV spectroscopy can be used for such differentiation.
  -  will absorb at longer wavelength due to greater substitution at the double bond.
  -  will have larger  $\lambda_{\text{max}}$  due to the same reason as stated in part (a).
  -  will have larger  $\lambda_{\text{max}}$  because all the three double bonds are in conjugation in this molecule.
- two signals: i) a *triplet* for  $-\text{CH}_3$  protons  
ii) a *quartet* for  $-\text{CH}_2-$  protons.
  - two signals: i) a *doublet* for  $-\text{CH}_3$  protons.  
ii) a *septet* for  $-\text{CHI}-$  protons.
- having  $m/z = 46$  can be  $\text{CH}_3\text{OCH}_3$  or  $\text{CH}_3\text{CH}_2\text{OH}$  or  $\text{HC}-\overset{\text{O}}{\parallel}{\text{O}}\text{H}$  and
  - having  $m/z = 30$  can be  $\text{HCHO}$ .



# UNIT 5 STRUCTURE – REACTIVITY RELATIONSHIPS

## Structure

- 5.1 Introduction
  - Objectives
- 5.2 What are Acids and Bases?
- 5.3 Strengths of Acids and Bases
- 5.4 Factors Affecting the Strengths of Acids and Bases
  - Inductive Effect
  - Resonance Effect
  - Hyperconjugation
  - Hydrogen Bonding
  - Steric Effect
  - Solvent
- 5.5 Tautomerism
- 5.6 Summary
- 5.7 Terminal Questions
- 5.8 Answers

## 5.1 INTRODUCTION

In Unit 4, you studied about the relationship between molecular structure and physical properties including spectral properties. In this unit, you will study about the effect of molecular structure on the reactivity of the molecules. The *reactivity* of one substance towards another is measured by the rate at which the two substances react and the amount of the products formed.

Not all molecules are equally reactive. But, what makes some organic molecules more reactive than others? To find an answer to this question, we should have some idea of the nature of reactions that the organic molecules undergo. A large number of reactions that the organic molecules undergo can be readily understood as simple analogies of *acid-base reactions*. Therefore, it is important for us to know the basic features of acid-base reactions. We will begin this unit with a discussion on various ways in which the acids and bases can be defined. We will then familiarise you with the concept of acid-base equilibrium. Here, you will also study that the position of the acid-base equilibrium is a measure of molecular reactivity; further it is influenced by many factors. Although, the functional groups present in a molecule are of key importance in determining the molecular reactivity, it has been observed that various compounds containing the same functional groups differ in their reactivities. Thus, in addition to the presence of the functional groups, the nature and arrangement of atoms attached to the functional groups also control the molecular reactivity. These effects which are associated with the change in molecular structure, are called **structural effects**. In this unit, you will study various structural effects such as *inductive effect*, *resonance effect* and *steric effect*, and their influence on molecular reactivity.

In addition to the structural effects, we will also discuss solvent effects and hydrogen bonding which are also important factors affecting the rate and the extent of such reactions. Finally, you will study an interesting equilibrium involving a proton shift from one atom of a molecule to another, called **tautomerism**.

### Objectives

After studying this unit, you should be able to:

- define acids and bases,
- classify the given compounds as acids or bases according to Brønsted – Lowry and Lewis definitions,
- define  $pK_a$  of an acid,

- predict the relative acidities and basicities of compounds from their  $pK_a$  values,
- list various factors affecting the strengths of acids and bases,
- explain the effect of structural changes on the acidic and basic behaviour of organic molecules,
- predict the relative reactivity of the molecules on the basis of inductive effect, resonance effect, steric effect, hydrogen bonding and hyperconjugation, etc.
- define tautomerism and give examples of various kinds of tautomerism.

## 5.2 WHAT ARE ACIDS AND BASES ?

There are various ways of defining acids and bases. According to Arrhenius (1884), a Swedish chemist, an *acid* is a substance which ionises in aqueous solution to produce hydrogen ions ( $H^+$ ), also known as *protons*. And, a *base* is a substance which ionises to produce hydroxide ( $OH^-$ ) ions. Thus, Arrhenius theory assumes a simple dissociation such as,

Arrhenius received Nobel Prize in Chemistry in 1903.

Note that during dissociation, the covalent bond between  $H-A$  is broken and the electrons forming this bond shift on  $A$  as shown by the curved arrow.



and



Thus,  $HCl$  is an acid and  $NaOH$  is a base because on dissociation they yield  $H^+$  and  $OH^-$  ions, respectively. Thus, the strength of these acids and bases is related to the degree of their dissociation. The mineral acids such as  $HCl$ ,  $HI$ ,  $HBr$ ,  $H_2SO_4$  and  $HNO_3$  are strong acids because they are almost completely dissociated in aqueous solutions. Similarly, the strength of a base will also depend upon its degree of dissociation.

An alternative theory of acids and bases was devised independently by Brønsted and Lowry in 1923. According to the Brønsted-Lowry approach, an **acid is a proton donor and a base is a proton acceptor**. Since under ordinary reaction conditions a free proton cannot exist as a separate entity, when an acid in the Brønsted-Lowry sense is considered, a base must be present to accept the proton from the acid. Consider the following example,

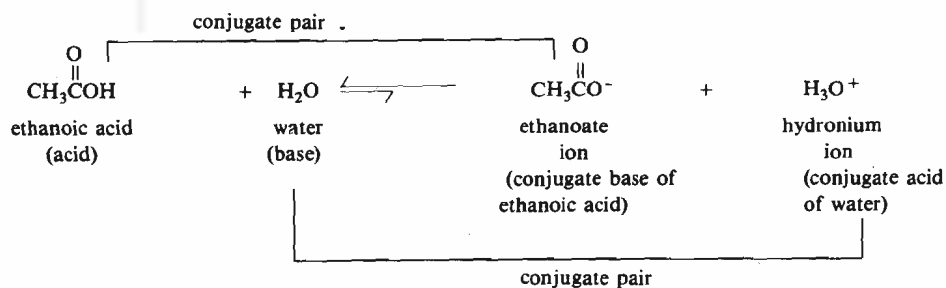

The Brønsted acids are also called **protic acids** because they react by the transfer of a *proton*.

The word **conjugate** has its origin from the Latin word *conjungatus* which means *joined together*.

Here, the ethanoic acid is an **acid** because it donates a proton to water which is a base because it accepts the proton. Similarly, the ethanoate ion, which is formed by the loss of a proton from ethanoic acid, functions as a **base** because it can accept a proton to become ethanoic acid again. Thus, ethanoate ion is called the **conjugate base** of ethanoic acid. Similarly, the hydronium ion is the **conjugate acid** of the base, water. This pair of a base and its conjugate acid or an acid and its conjugate base is also called **conjugate acid-base pair**.

Let us now consider an acid-base reaction involving methylamine which acts as a base and water which acts as an acid in this case, as shown below :



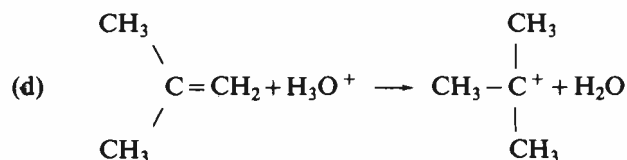
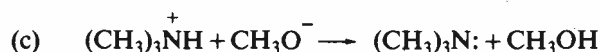
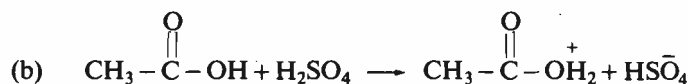
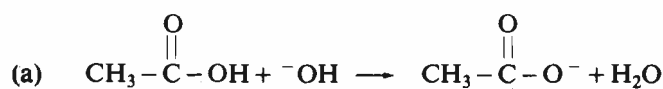

### 5.3 STRENGTHS OF ACIDS AND BASES

It is not possible to determine the strength of an acid or a base in absolute terms. Therefore, these strengths are always expressed in relative terms. The *relative strengths* of acids are determined by the extent to which they transfer a proton to a standard base. The standard base which is commonly used for such comparisons, is water. Hence, for an acid HA, the proton transfer can be represented by the following equilibrium :

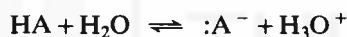

The equilibrium constant,  $K_{\text{eq}}$ , for the above equilibrium can be written as,

$$K_{\text{eq}} = \frac{[\text{:A}^-] [\text{H}_3\text{O}^+]}{[\text{HA}] [\text{H}_2\text{O}]} \quad \dots(5.1)$$

where the quantities in brackets are the molar concentrations (expressed as moles  $\text{dm}^{-3}$ ) of the species at equilibrium.

For dilute solutions, the concentration of water is large and is almost constant. Hence, the above expression for equilibrium constant can be rewritten in terms of a new constant,  $K_a$ , called the **acidity constant**, as given below:

$$K_{\text{eq}} [\text{H}_2\text{O}] = K_a = \frac{[\text{:A}^-] [\text{H}_3\text{O}^+]}{[\text{HA}]} \quad \dots(5.2)$$

The dissociation of an acid HA in solvents other than water can be generalised as,



The expression for acidity constant can then be written as follows:

$$K_a = \frac{[\text{H}^+ \text{-- solvent}] [\text{:A}^-]}{[\text{HA}]} \quad \dots(5.3)$$

The acidity constants of different acids have magnitudes ranging from  $10^{14}$  to  $10^{-50}$ . In order to avoid writing a wide range of powers of 10,  $K_a$  is generally expressed in terms of  $\text{p}K_a$ , where

$$\text{p}K_a = -\log_{10} K_a \quad \dots(5.4)$$

Table 5.1 shows the  $\text{p}K_a$  values for a variety of acids along with their conjugate bases.

Taking  $-\log$  of Eq. 5.2 and rearranging, we get

$$-\log K_a = -\log [\text{H}_3\text{O}^+] + \log \frac{[\text{HA}]}{[\text{:A}^-]}$$

By definition,

$$-\log K_a = \text{p}K_a$$

and  $-\log [\text{H}_3\text{O}^+] = \text{pH}$

Hence,

$$\text{p}K_a = \text{pH} + \log \frac{[\text{HA}]}{[\text{:A}^-]}$$

This expression relating the  $\text{p}K_a$  and pH is also known as **Henderson-Hasselbalch equation**.

Thus, when  $[\text{HA}] = [\text{:A}^-]$  then  $\text{p}K_a = \text{pH}$ .

Table 5.1 : pKa Values



Acid	Base	pKa
H <sub>2</sub> SO <sub>4</sub>	HSO <sub>4</sub> <sup>-</sup>	-9
HCl	Cl <sup>-</sup>	-7
H <sub>3</sub> O <sup>+</sup>	H <sub>2</sub> O	-1.7
HNO <sub>3</sub>	NO <sub>3</sub> <sup>-</sup>	-1.3
		-0.6
		0.25
		0.8
		3.4
		2.7
		4.2
		4.6
		4.8
		5.2
		7.2
		7.8
NH <sub>4</sub> <sup>+</sup>	NH <sub>3</sub>	9.4
(CH <sub>3</sub> ) <sub>3</sub> NH <sup>+</sup>	(CH <sub>3</sub> ) <sub>3</sub> N	9.8
		10.0
CH <sub>3</sub> CH <sub>2</sub> SH	CH <sub>3</sub> CH <sub>2</sub> S <sup>-</sup>	10.5
CH <sub>3</sub> NH <sub>3</sub> <sup>+</sup>	CH <sub>3</sub> NH <sub>2</sub>	10.6
CH <sub>3</sub> OH	CH <sub>3</sub> O <sup>-</sup>	15.5
H <sub>2</sub> O	OH <sup>-</sup>	15.7
CH <sub>3</sub> CH <sub>2</sub> OH	CH <sub>3</sub> CH <sub>2</sub> O <sup>-</sup>	17
		19
CHCl <sub>3</sub>	$\bar{\text{C}}\text{Cl}_3$	25
HC≡CH	HC≡C <sup>-</sup>	26
NH <sub>3</sub>	NH <sub>2</sub> <sup>-</sup>	36
CH <sub>2</sub> =CH <sub>2</sub>	CH <sub>2</sub> =CH <sup>-</sup>	36
CH <sub>4</sub>	CH <sub>3</sub> <sup>-</sup>	49

Table 5.1 shows that the acids which are listed at the top are strong acids. For strong acids such as H<sub>2</sub>SO<sub>4</sub>, the proton transfer to the base (i.e., water) is almost

## Fundamental Concepts

The stronger the acid, the weaker is its conjugate base and vice versa.

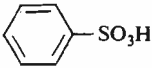
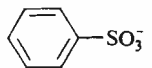
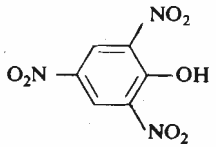
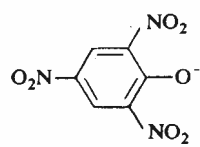
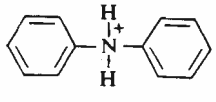
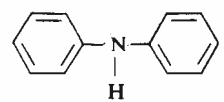
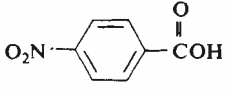
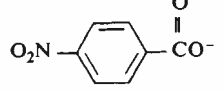
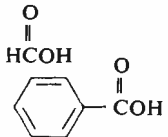
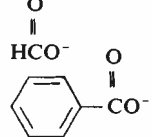
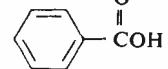
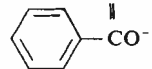
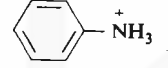
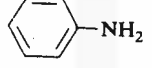
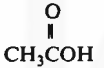
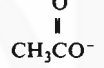
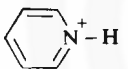
Lewis acids such as boron trifluoride and aluminium chloride are important acid catalysts for certain organic reactions.

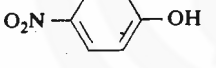
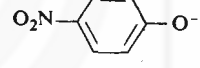
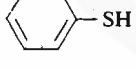
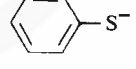
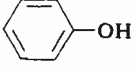
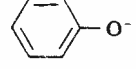
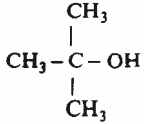
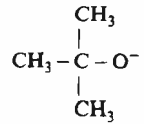
complete and equilibrium lies towards the right. Thus, the stronger acids have larger  $K_a$  values. Therefore, it follows from Eq. 5.4 that the **stronger** the acid, the **smaller** the  $pK_a$  value. Thus, as Table 5.1 shows, the sulphonic acids and carboxylic acids are much more acidic as compared to phenol and alcohols.

Remember that the conjugate base of a strong acid will be a weak base and the conjugate base of a weak acid will be a strong base. Similarly, we can generalise for conjugate acids.

Note that Table 5.1 lists the  $pK_a$  values for protic acids or Brønsted acids only. A similar Table for the relative acidities of Lewis acids is not feasible because in these acids it is not possible to have a standard base as reference. But, an approximate order of the strengths of various Lewis acids is as given below :

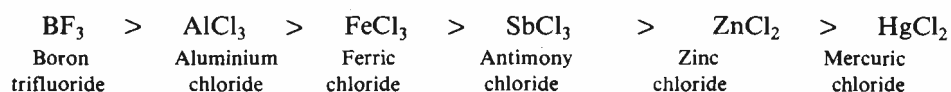

The Table of  $pK_a$  values can be used to predict the feasibility of an acid-base reaction. In general, an acid will transfer a proton to the conjugate base of any acid that is below it in the  $pK_a$  Table. Also, the larger the difference between the  $pK_a$  values (i.e., acidities) of the acid and the conjugate acid of the base, the more favourable will be the proton transfer from the acid to the base.

Many organic reactions are initiated by protonation or deprotonation of a reactant, therefore, the  $pK_a$  values are also helpful in choosing the appropriate acidic or basic reagents required for a particular reaction.

Similar to acids, an equilibrium for bases in water can be written as,

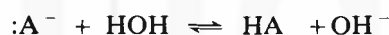

The equilibrium constant for such an equilibrium can be expressed as,

$$K_{\text{eq}} = \frac{[\text{HA}] [\text{OH}^-]}{[:A^-] [\text{HOH}]} \quad \dots(5.5)$$

where the quantities in brackets are molar concentrations of the respective species at equilibrium.

Since the reaction is carried out in aqueous solution, water is acting both as a solvent as well as an acid; hence, its concentration can be taken as almost constant. Thus, we can write Eq. 5.5 in terms of the basicity constant,  $K_b$ , as

$$K_{\text{eq}} [\text{H}_2\text{O}] = K_b = \frac{[\text{HA}] [\text{OH}^-]}{[:A^-]} \quad \dots(5.6)$$

The two constants  $K_a$  and  $K_b$  are related to each other as shown below :

$$\begin{aligned} K_a \cdot K_b &= \frac{[:A^-] [\text{H}_3\text{O}^+]}{[\text{HA}]} \cdot \frac{[\text{HA}] [\text{OH}^-]}{[:A^-]} \\ &= [\text{H}_3\text{O}^+] [\text{OH}^-] = K_w = 10^{-14} \end{aligned}$$

where  $K_w$  is the self-ionisation constant of water. Hence,

$$pK_a + pK_b = 14$$

Therefore, if we know the  $pK_a$  of acid HA, the  $pK_b$  of the base  $:A^-$  can be obtained by using the above relation.

It is customary to express the strengths of organic bases not as  $K_b$  values but in terms of the  $K_a$  and  $pK_a$  values because it allows a single continuous scale for both acids and bases. As has been stated above the stronger the acid, the weaker will be its conjugate base and vice versa. In other words, the stronger the acid, the lower the  $pK_a$ , but, the stronger the base, the higher is the  $pK_a$ . This is also evident from Table 5.1 that whereas the acidity of the acids *decreases* from top to bottom, the basicity of the conjugate bases *increases* from top to bottom. You can see that  $\text{NH}_2^-$ , which comes almost at the bottom of this Table, is a very strong base (see

In the expressions for  $K_a$  and  $K_b$ , the concentration of water is generally omitted and hence,  $K_a$  and  $K_b$ , have units of moles  $\text{dm}^{-3}$ .

The self-ionisation of water can be represented as,



The concentration of the species  $\text{H}_3\text{O}^+$  and  $\text{OH}^-$  in pure water is very low and is equal to  $10^{-7}$  moles  $\text{dm}^{-3}$ . Therefore, the self-ionisation constant,  $K_w$ , of water is defined as,

$$\begin{aligned} K_w &= [\text{H}_3\text{O}^+] [\text{OH}^-] \\ &= 10^{-7} \times 10^{-7} \text{ moles}^2 \text{ dm}^{-6} \\ &= 10^{-14} \text{ moles}^2 \text{ dm}^{-6} \end{aligned}$$

Table 5.1). A comparison of the  $pK_a$  values from Table 5.1 shows the following order of the basicities for some of the bases.

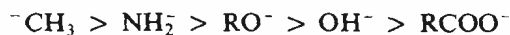

Note that the organic compounds which act as bases can be regarded as alkyl derivatives of either water or ammonia; for example, alcohols (R–O–H), ethers (R–O–R') and amines  $\text{RNH}_2$ ,  $\text{R}_2\text{NH}$  and  $\text{R}_3\text{NH}$ . The basic character of these compounds can be attributed to atoms such as nitrogen and oxygen which contain at least one lone pair of electrons.

Having discussed the strengths of acids and bases, let us now study the factors affecting the strength of acids and bases. But before proceeding to the study of next section which deals with these factors, answer the following SAQ.

### SAQ 2

An acid  $\text{HA}_1$  has  $pK_a = 20$  and another acid  $\text{HA}_2$  has  $pK_a = 10$ .

(a) Which of these two acids is stronger?

(b) If  $\text{Na}^+ \text{A}_1^-$  salt is added to acid  $\text{HA}_2$ , does any acid base reaction take place? Explain.

.....

.....

.....

.....

.....

## 5.4 FACTORS AFFECTING THE STRENGTHS OF ACIDS AND BASES

The strengths of acids and bases depend upon many factors. It was mentioned before, that apart from the presence of functional groups, structural variations in molecules also influence their acidic or basic properties. We will now focus our attention on some effects which arise due to structural changes in the molecules. A change in molecular structure can affect the reactivity of the molecule by changing the *electron distribution* of the system, in which case it is called an **electronic effect**. Another possibility is that two or more groups or atoms may come close enough in space so that the London interactions between them become significant. The effects arising from such interactions are called **steric effects**.

We will begin our discussion with the study of an electronic effect, known as **inductive effect**.

### 5.4.1 Inductive Effect

You are already familiar with the fact that when two different atoms form a covalent bond, the shared pair of electrons is pulled more by the more electronegative atom. This unequal electron distribution results in partial separation of charge and we get a dipole in which one atom has a partial positive charge and another atom (the more electronegative one) has a partial negative charge. Such a polarisation of a bond can be felt by adjacent groups also. This phenomenon of the transmission of charge through a chain of atoms linked together by  $\sigma$  bonds is called **inductive effect**.

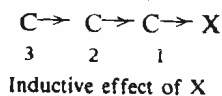
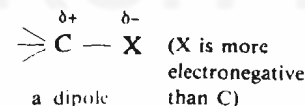

Note that the inductive effect is a permanent effect

Let us now analyse how inductive effect causes a change in the acidity or basicity of a molecule. Let us take the example of ethanoic acid whose structure is shown below.

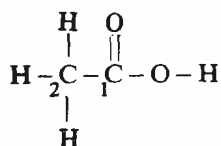

ethanoic acid  
 $pK_a$  4.76

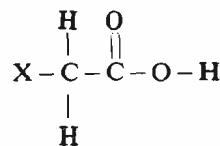

substituted  
ethanoic acid

### Fundamental Concepts

i) When the substituent X is electron withdrawing, it decreases the electron density at H as shown below:

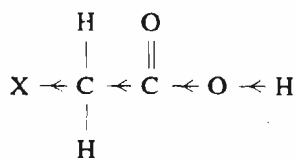



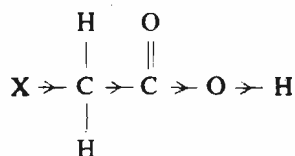



ii) When the substituent X is electron donating, it increases the electron density at H as represented below:



If we substitute one of the hydrogen atoms on the C-2 carbon atom with a substituent X, then, the nature of the substituent group may effect the electron density of the O-H bond resulting in a change in the acidity of the molecule. Depending upon whether the substituent X is electron-withdrawing or electron donating, the electron density will decrease or increase, respectively. If the electron density between the bond formed by O and H atoms *decreases*, then, the loss of H as H<sup>+</sup> ion is facilitated resulting in the *increased acidity* of the molecule. On the other hand, an *increase* in the electron density at the bond between O and H atoms will make the proton release difficult, thereby, *decreasing* the acidity.

The electron withdrawing substituents are said to have -I effect and the electron-donating substituents are said to have +I effect. Some examples of the substituents belonging to these two categories are listed in Table 5.2.

Table 5.2 : Inductive effect of various functional groups.

Electron-donating substituents (+I)	Electron-withdrawing substituents (-I)		
-O <sup>-</sup>	-F	-CO <sub>2</sub> H	
-CH <sub>3</sub>	-Cl	-CO <sub>2</sub> R	
-CO <sub>2</sub> -	-Br		
	-I	-C≡N	
	-OR	-NO <sub>2</sub>	
	-OH	-SO <sub>2</sub> -	
			
	-SR	-C≡C-	
	-SH		

The effect of some of these substituents on the acidity of the substituted acids in terms of their pK<sub>a</sub> values is shown in Table 5.3.

Table 5.3 : pK<sub>a</sub> values for some substituted acids determined in water at 298 K.

Name	Structure	pK <sub>a</sub>
ethanoic acid	$\begin{array}{c} \text{O} \\    \\ \text{CH}_2\text{COH} \\   \\ \text{H} \end{array}$	4.76
propanoic acid	$\begin{array}{c} \text{O} \\    \\ \text{CH}_2\text{COH} \\   \\ \text{CH}_3 \end{array}$	4.87
fluoroethanoic acid	$\begin{array}{c} \text{O} \\    \\ \text{CH}_2\text{COH} \\   \\ \text{F} \end{array}$	2.59
chloroethanoic acid	$\begin{array}{c} \text{O} \\    \\ \text{CH}_2\text{COH} \\   \\ \text{Cl} \end{array}$	2.86
bromoethanoic acid	$\begin{array}{c} \text{O} \\    \\ \text{CH}_2\text{COH} \\   \\ \text{Br} \end{array}$	2.90
iodoethanoic acid	$\begin{array}{c} \text{O} \\    \\ \text{CH}_2\text{COH} \\   \\ \text{I} \end{array}$	3.17



Table 5.3 shows the decreased acidity for propanoic acid (larger  $pK_a$  value) as compared to the ethanoic acid. Note that the propanoic acid has a methyl group in place of H in ethanoic acid. The methyl group is electron-donating in nature and, therefore, has a +I effect which results in the decrease in the acidity. But the acidity increases when the electron-withdrawing substituents such as F, Cl, Br and I are present. Note that the increase in acidity is in accordance with the electronegativity of these elements.

The inductive effect of these substituents is further enhanced with the increase in the number of these substituents. This is represented in Table 5.4.

Table 5.4 : Effect of increase in the number of chlorine substituents on acidity of ethanoic acid.

Acid	Structure	$pK_a$
Ethanoic acid	$\begin{array}{c} \text{H} \quad \text{O} \\   \quad    \\ \text{H}-\text{C}-\text{C}-\text{O}-\text{H} \\   \\ \text{H} \end{array}$	4.76
Monochloroethanoic acid	$\begin{array}{c} \text{Cl} \quad \text{O} \\   \quad    \\ \text{H}-\text{C}-\text{C}-\text{O}-\text{H} \\   \\ \text{H} \end{array}$	2.86
Dichloroethanoic acid	$\begin{array}{c} \text{Cl} \quad \text{O} \\   \quad    \\ \text{Cl}-\text{C}-\text{C}-\text{O}-\text{H} \\   \\ \text{H} \end{array}$	1.30
Trichloroethanoic acid	$\begin{array}{c} \text{Cl} \quad \text{O} \\   \quad    \\ \text{Cl}-\text{C}-\text{C}-\text{O}-\text{H} \\   \\ \text{Cl} \end{array}$	0.65

In monochloroethanoic acid, one of the three hydrogen atoms in ethanoic acid has been replaced by an electron withdrawing chlorine atom. Hence, the electron pair constituting the C–Cl bond is drawn closer to the chlorine atom. This effect is transmitted through other atoms forming  $\sigma$  bonds to the OH bond of the

$-\overset{\text{O}}{\parallel}{\text{C}}-\text{O}-\text{H}$  group. This results in a shift of the electrons constituting the O–H bond towards oxygen atom as shown below :

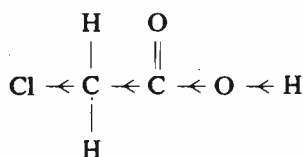

monochloroethanoic acid

Such an electron withdrawal by chlorine atom, thus, facilitates the departure of the proton and hence, increases the acidic character of monochloroethanoic acid as compared to ethanoic acid.

In the di- and trichloroethanoic acids, the presence of second and third chlorine

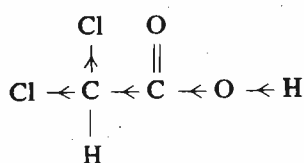

dichloroethanoic acid

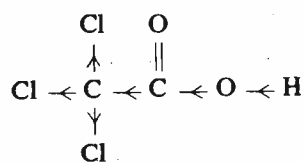

trichloroethanoic acid

atoms results in more electron withdrawal away from hydrogen of the O–H bond and would, therefore, further increase the acidity of these compounds as compared to ethanoic acid or chloroethanoic acid. Therefore, we can arrange these acids in the increasing order of their acidities as ethanoic acid < chloroethanoic acid < dichloroethanoic acid < trichloroethanoic acid.

The position of electron-withdrawing substituents in a molecule also influences its acidic character. This is shown by the  $pK_a$  values of isomeric monochlorobutanoic acids given in Table 5.5.

Table 5.5 : Effect of position of substituent on acidity.

Name	Structure	$pK_a$
butanoic acid	$\begin{array}{c} \text{O} \\ \parallel \\ \text{CH}_3\text{CH}_2\text{CH}_2\text{COH} \end{array}$	4.82
2-chlorobutanoic acid	$\begin{array}{c} \text{O} \\ \parallel \\ \text{CH}_3\text{CH}_2\text{CHCOH} \\   \\ \text{Cl} \end{array}$	2.86
3-chlorobutanoic acid	$\begin{array}{c} \text{O} \\ \parallel \\ \text{CH}_3\text{CHCH}_2\text{COH} \\   \\ \text{Cl} \end{array}$	4.05
4-chlorobutanoic acid	$\begin{array}{c} \text{O} \\ \parallel \\ \text{CH}_2\text{CH}_2\text{CH}_2\text{COH} \\   \\ \text{Cl} \end{array}$	4.52

It can be seen that although in each of these acids a chlorine atom has replaced a hydrogen atom but they show different acidities. Note that as the distance of the electron withdrawing chlorine atom from the reaction site (i.e., the O–H of the COOH group) increases, the acid strength decreases. Thus, the influence of the inductive effect on acid strength is greatest when the electron withdrawing chlorine atom is present on the carbon next to the carboxylic group and it diminishes quickly with increase in the distance. This effect is almost negligible after the fourth carbon atom in the chain.

A similar electron withdrawal occurs when a positively charged group is present in a molecule. A positive centre such as  $(\text{CH}_3)_3\text{N}^+$  (trimethyl ammonium) or  $-\text{NH}_3^+$  (ammonium), eases the departure of proton by withdrawing electrons and hence, increases the acid character of the molecule. This is illustrated in the example given below :



Note that here also with the increase in the distance between the positively charged group and the carboxyl group, the inductive effect decreases.

If the presence of a positively charged group increases the acidity of a molecule, then a negatively charged group should decrease the acidity. Consider the dissociation of propanedioic acid, as given below:

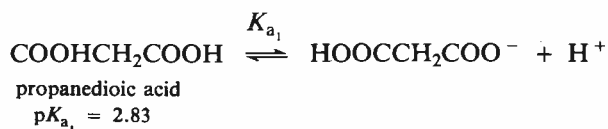

where  $K_{a_1}$  is the first dissociation constant.

Here, a proton is lost from one of the two carboxyl groups of the molecule. The dissociation constant for this dissociation is called the first dissociation constant and is represented by  $K_{a_1}$ . Further dissociation of the anion obtained in the above dissociation is difficult because it involves the removal of the proton from a negatively charged species. Therefore, this step has a  $pK_{a_2}$  value equal to 5.69. This is called  $pK_{a_2}$  because  $K_{a_2}$  represents the second dissociation constant.

From the above discussion, we can say that the substituents having  $-I$  effect increase the acidity while the substituents having  $+I$  effect decrease the acidity. On this basis, let us now analyse the stability of carbocations which are reactive intermediates formed during the chemical reactions. You are already familiar with the shape of the carbocations which you studied in Unit 3 under the stereochemistry of  $S_N1$  reactions. Look at the following examples of carbocations:

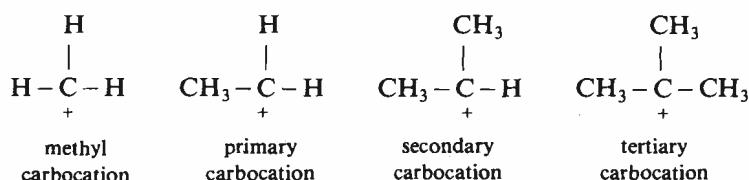

The carbocations are classified by the degree of alkyl substitution at the positively charged carbon atom as primary, secondary or tertiary carbocations, as shown below :

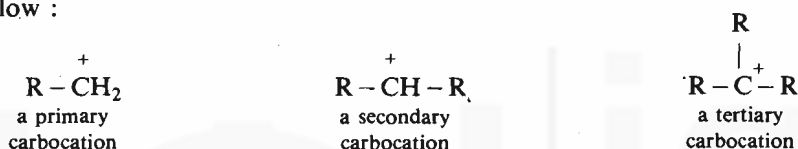

where R is the alkyl group.

Since the alkyl groups are electron donating in nature, the  $+I$  effect increases with the increase in the number of alkyl groups. Thus, the increase in the number of alkyl groups in a carbocation helps in the dispersal of its positive charge.

Therefore, a tertiary carbocation is more stable than a secondary carbocation ion which is, in turn, more stable than a primary carbocation. Hence, we can arrange the above carbocations in the following order of their stabilities:

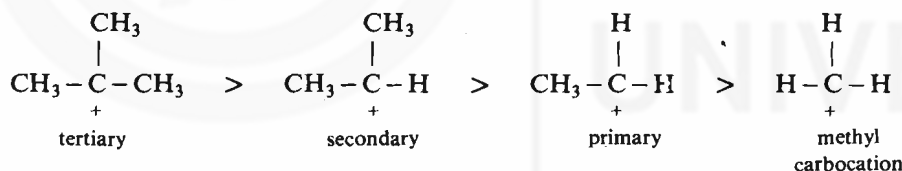

Since the substituents having  $+I$  effect decrease the acidity, their presence should also increase the basicity. This is what is actually observed when the hydrogen atoms of ammonia are successively replaced by methyl groups to give methylamine and dimethylamine whose basicities increase with the increase in the number of methyl groups, as shown below by the  $pK_a$  values of their conjugate acids.

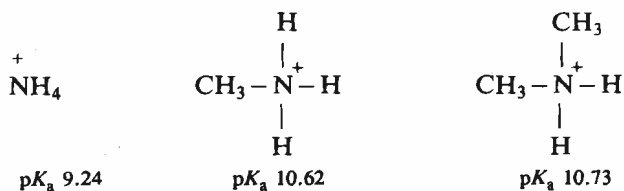

The basicity of tertiary amines will be discussed in sub-Sec. 5.4.5.

Till now, you have been studying the inductive effect of various substituents on the acidities and basicities of molecules. In fact, the inductive effect influences the electron density of the  $\text{H}-\text{A}$  bond. Another factor which affects the release of protons from the acid  $\text{HA}$  is the stability of the anion,  $\text{A}^-$ , formed by the loss of proton from the acid  $\text{HA}$ . This you will be studying in the next section.

At this stage, it would be helpful to answer the following SAQ.

## SAQ 3

(a) Arrange the following compounds in the decreasing order of their acid strengths. Also, give reasons in support of your answer.

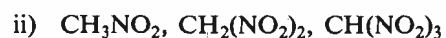

(b) Arrange the following compounds in the decreasing order of their base strength. Support your answer with reasons.



## 5.4.2 Resonance Effect

One of the factors which stabilises the  $\text{A}^-$  anion with respect to the acid HA, is *resonance effect*. Let us first revise the basic ideas about resonance which you have learnt earlier in Unit 4, Block 1 of Atoms and Molecules course and then we will discuss the effect of resonance on the acidity and basicity of molecules.

## Resonance

You are already familiar with the fact that some covalent molecules or ions cannot be represented satisfactorily by a single Lewis structure. Therefore, for such species, more than one Lewis structure is possible. These Lewis structures are called **resonance structures** or **resonance contributors** and the actual molecule or ion is said to be a **resonance hybrid** of these resonance structures. Since we will be dealing with the resonance structures of various molecules in explaining their reactivity, we should be able to write all the possible resonance structures of a molecule. For this purpose, certain rules are to be followed. These rules are as listed below:

Not that a double headed arrow ( $\longleftrightarrow$ ) is used to represent the resonance contributors. It should be clear to you that it does not mean that the resonance contributors are in rapid equilibrium but it implies that the actual molecule has one structure which has the contribution from various resonance contributors.

1. Only nonbonding electrons and electrons constituting the multiple bonds change locations from one resonance contributor to another. The electrons in single covalent bonds are not involved. This is shown in the examples below :

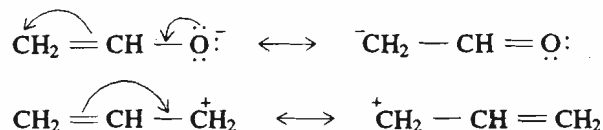

2. The nuclei of various atoms in different resonance contributors are in the same position. Hence, the structures which are shown below are not resonance structures because the location of the chlorine atom is different in them.



3. All resonance contributors must have the same number of paired and unpaired electrons. This is illustrated below :

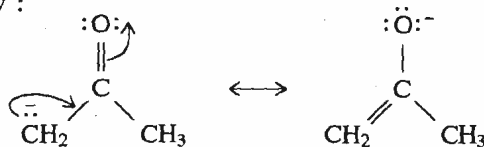

It is important to understand that the individual resonance structures have no reality and the actual compound is not a mixture of the various resonance contributors, but it is a **weighted average** of these structures. When we use the words **weighted average**, it is implied that some resonance structures are more important than the others and therefore, contribute more to the hybrid structure. But, how to know which structure is more important than the others. To evaluate the relative importance of various resonance structures, their stabilities are compared by considering each structure as a separate entity or species. In other words, we assume each resonance structure to be real. Thus, the most stable structures are the most important ones. Given below are some guidelines to enable you to assess the relative importance of resonance structures.

1. *Identical resonance structures are equally important and contribute equally towards the actual structure of a molecule.* For example, the following resonance structures contribute equally to the actual structure of the molecule.

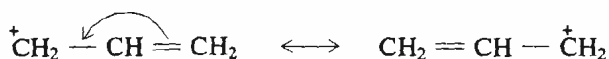

2. *Resonance contributors having greater number of bonds are more important.* Thus, in the following resonance structures, the one on the left hand side is more important.

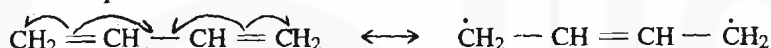

more important

Single headed arrow denotes the movement of an electron.

3. *Resonance contributors with little or no charge separation are more important than those having the large separation of charge.* Therefore, among the three resonance structures shown below, the first one is the most important.

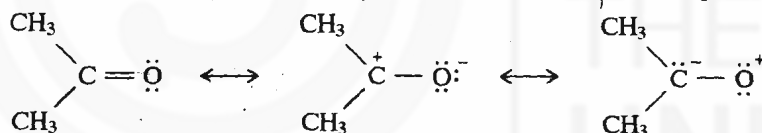

most important

4. *In case of resonance contributors having separation of charge, the resonance contributor having the negative charge on the more electronegative atom is more important.*

Hence, in the following two resonance structures, the one in which the more electronegative oxygen atom carries the negative charge is more important.

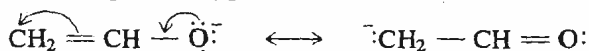

more important

5. *Resonance structures in which the atoms of elements from the second period of the periodic table have eight electrons around them are more important than those in which these atoms have less than eight electrons.*
6. *Resonance structures that help in delocalisation of charge or of unpaired electrons are important.*

Having understood how to assign the relative importance to various resonance structures, let us now consider why resonance structures are important in deciding the stability of a molecule. Since the resonance structures of a molecule are symbolic representations of the additional bonding associated with the orbital overlap, *the greater the number of important resonance structures, the greater is the stability of the actual molecule.* This stabilisation due to resonance is measured by the resonance energy which is the energy difference between the actual

Similar resonance stabilisation is not possible for the ethoxide ion because such a stabilisation is possible only if the system has  $\pi$  electrons. Because of the absence of resonance stabilisation of the ethoxide anion, ethanol is less acidic as compared to ethanoic acid.

Table 5.6 lists various groups which donate or withdraw electrons due to resonance. Groups which donate electrons by resonance are called +R groups. Some examples of the +R groups being the hydroxy (-OH), amino (-NH<sub>2</sub>), alkoxy (-OR), halogens (-X) and alkylamino (-NHR and, -NR<sub>2</sub>) groups. On the other hand, the groups which withdraw electrons by resonance are called -R groups. The examples of -R groups are nitro (-NO<sub>2</sub>), cyano (-C≡N), carbonyl (>C=O), and sulphonic (-SO<sub>3</sub>H) groups.

Table 5.6 : Resonance effects of various groups.

Electron donating +R groups	Electrons withdrawing -R groups
-F	-C≡N
-Cl	
-Br	$\begin{array}{c} \text{O} \\    \\ -\text{C}- \end{array}$
-I	-SO <sub>2</sub> -
-O <sup>-</sup>	-NO <sub>2</sub>
-OR	
-OH	
$\begin{array}{c} \text{O} \\    \\ -\text{O}-\text{C}-\text{R} \end{array}$	
-N<	
-SR	
-SH	
-CH <sub>3</sub>	

Let us now study how resonance affects the acidity and basicity of various molecules. Consider the pK<sub>a</sub> values for ethanoic acid and ethanol as given below:

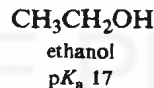
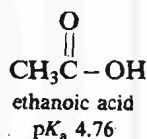

Consider the dissociation of these compounds as shown below:

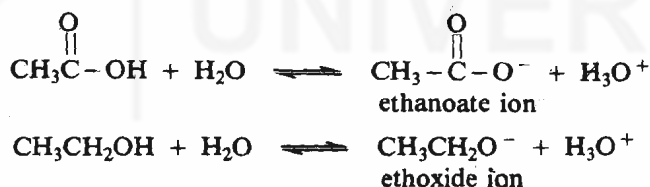

We find that the anion of ethanoic acid can be represented as a resonance hybrid of the following two resonance structures.

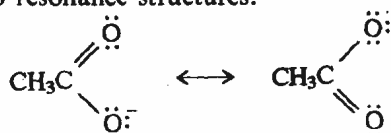

Since these two structures are equivalent, they contribute equally to the actual structure which can be represented as shown below :

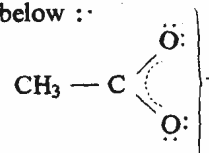

Thus, we can say that in the ethanoate anion the charge is not localised on any one of the oxygen atoms but is distributed equally, or is delocalised, over both the oxygen atoms. This dispersal of charge resulting from the delocalisation stabilises this anion. But, the delocalisation of charge reduces the availability of electrons, thereby resulting in the decrease in the basicity of the anion. Hence, the equilibrium lies in the forward direction resulting in the dissociation of the acid.

of the alkyl groups. Let us consider again a primary carbocation, such as the one shown below in Fig. 5.1.

Similar resonance stabilisation is not possible for the ethoxide ion because such a stabilisation is possible only if the system has  $\pi$  electrons. Because of the absence of resonance stabilisation of the ethoxide anion, ethanol is less acidic as compared to ethanoic acid.

The acidity of phenols can also be explained using the resonance phenomenon about which you will study in Unit 12. However, you will study the effect of resonance on the reactivity of aromatic compounds in Unit 9.

Similar to acidity, the basicity of compounds is also affected by the resonance. For example, in case benzenamine (aniline), in addition to the electron withdrawing nature ( $-I$  effect) of the aryl group, the following resonance structure are possible.

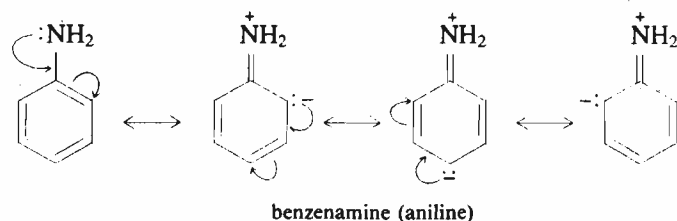

These resonance structures clearly show that the nonbonding electrons of the nitrogen atom are delocalised over the aromatic ring. Thus, the electron density at the nitrogen atom decreases which results in the lower basicity of aniline as compared to ammonia.

You can check your knowledge of resonance by answering the following SAQ.

#### SAQ 4

Draw resonance structures for the following species to rationalise the facts given with them.

- a)  $\text{H}_2\text{C}=\overset{+}{\text{O}}-\text{H}$  is the conjugate acid of methanal (formaldehyde) and has a substantial positive charge on carbon.

.....  
 .....  
 .....

- b) In acetonitrile oxide,  $\text{H}_3\text{C}-\overset{+}{\text{C}}=\overset{-}{\text{N}}-\overset{-}{\text{O}}:$ , the inner carbon can act as a Lewis acid.

.....  
 .....  
 .....

We will now study a special case of resonance which is known as **hyperconjugation**.

#### 5.4.3 Hyperconjugation

Hyperconjugation involves the conjugation of *sigma*-electrons with adjacent *pi* electrons, as shown below:

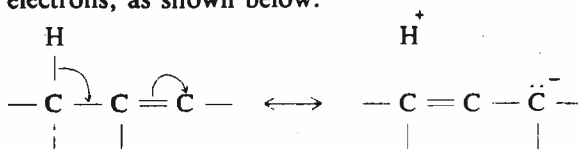

This is also known as  $\sigma - \pi$  conjugation.

This type of delocalisation leads to a situation where there is *no bond* between the hydrogen and the carbon atom of the molecule. Therefore, it is also known as **no-bond resonance**. Remember that the proton does not leave its position and since the nuclei or the atoms do not change their positions, therefore, the hyperconjugation becomes similar to resonance. Hyperconjugation also results in the delocalisation of charge, as you will now study in case of carbocations. The

Resonance structures discussed in this section involve  $\pi$  electrons and in some cases nonbonded electrons. In the next section, you will study hyperconjugation which involves  $\pi$  and  $\sigma$  electrons.

Hyperconjugation involving hydrogens is the most common.

## Activity

Make a model of this carbocation and convince yourself about the overlap as shown here.

stability of carbocations has been earlier explained on the basis of inductive effect of the alkyl groups. Let us consider again a primary carbocation, such as the one shown below in Fig. 5.1.

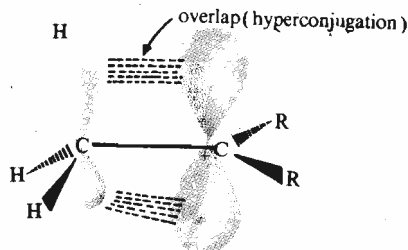
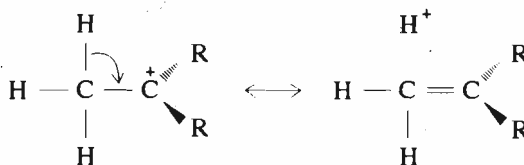

Fig. 5.1 : The hyperconjugation in a carbocation.

The C-H bond adjacent to the  $>C=C<$  or a carbocation is referred here as  $\alpha$ -C-H bond.

It is clear from the above structure that the electrons forming the  $\alpha$ -C-H bond can overlap, or spill over, into the empty  $p$  orbital of the carbon atom carrying the positive charge. The resulting hyperconjugation can be represented as illustrated below:



For hyperconjugation to occur, the substituent next to the positively charged carbon must have a filled  $\sigma$  orbital available to overlap with vacant  $p$  orbital of the carbon atom carrying the positive charge.

Note that hyperconjugation produces some additional bonding between the electron-deficient carbon and the adjacent carbon atom. Hence, hyperconjugation results in the stabilisation of carbocation by delocalising the positive charge. Obviously, the more the number  $\alpha$ -C-H bonds which can participate in hyperconjugation, the more stable will be the carbocation. You can see that in case of the primary carbocation shown above, there are three such  $\alpha$ -C-H bonds. Let us now examine the secondary and the tertiary carbocations.

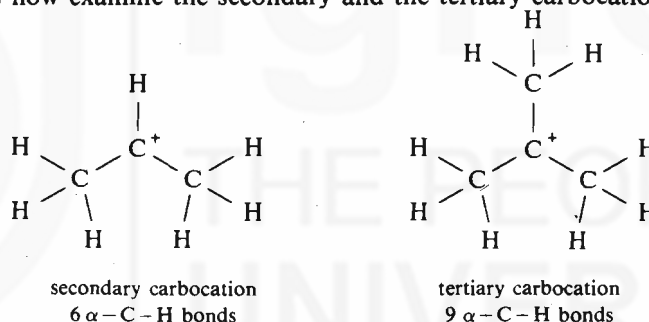

The secondary carbocation has 6  $\alpha$ -C-H bonds which can participate in hyperconjugation whereas the tertiary carbocation has 9  $\alpha$ -C-H bonds. Certainly, more delocalisation of charge is possible in case of a tertiary carbocation than in a secondary carbocation which is in turn more than that possible in a primary carbocation. Therefore, the tertiary carbocation is more stable than the secondary carbocation which is more stable than the primary carbocation.

Hyperconjugation has also been used to explain the relative stabilities of substituted alkenes. Consider the following order of stability of some alkenes.

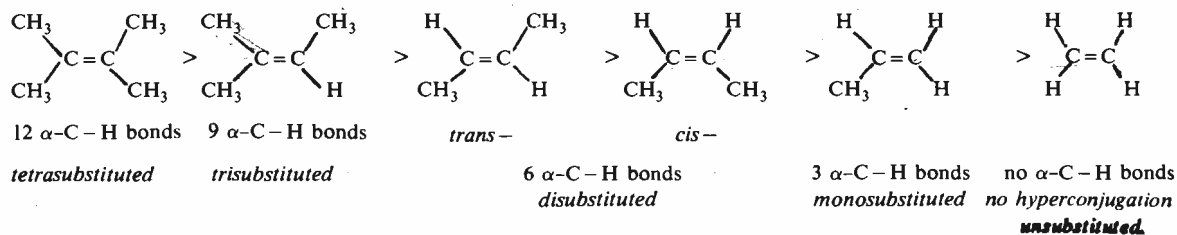

You can see that in an alkene, the more the number of  $\alpha$ -C-H bonds which can participate in hyperconjugation, the higher is its stability.

In spite of the fact that hyperconjugation can be used to explain many otherwise unconnected phenomena, it is controversial as it involves the formation a weaker  $\pi$  bond at the expense of a strong  $\sigma$  bond.



In addition to the resonance, another factor which contributes to the stability of the anion,  $A^-$ , is hydrogen bonding which you will now study.

### 5.4.4 Hydrogen Bonding

You are already familiar with the concept of hydrogen bonding from Unit 4 of this Block. If you analyse the  $pK_a$  values of benzenecarboxylic acid and 2-hydroxybenzenecarboxylic acid, as given below, then you will conclude that

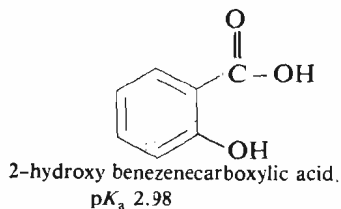
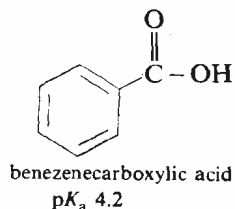

2-hydroxy benzenecarboxylic acid is much more acidic than benzenecarboxylic acid. This is because the anion formed from 2-hydroxybenzenecarboxylic acid is stabilised by hydrogen bonding, as shown below:

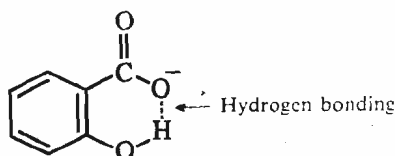

Hydrogen bonding stabilises the anion by delocalising the charge.

No similar stabilisation is possible for the benzenecarboxylate anion; therefore, benzenecarboxylic acid is less acidic than 2-hydroxybenzenecarboxylic acid.

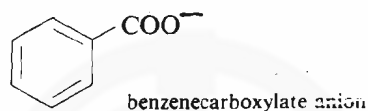

In the next section, you will study the steric effect on molecular reactivity.

### 5.4.5 Steric Effect

The effect arising from the spatial interactions between the groups is called the **steric effect**. You have already studied the effect of such interactions on the stability of geometrical isomers, (in Unit 2 where you studied that the *trans*- isomer is more stable than the *cis*- isomer) and conformational isomers, (in Unit 3 where you studied that the *staggered* conformation is more stable than the *eclipsed* conformation). As the acid-base behaviour or the molecular reactivity is related to the availability of the electrons, steric factors may also influence the molecular reactivity. For example, they can inhibit the delocalisation of charge, as is observed in case of *N,N*-dimethyl-*o*-toluidine. The delocalisation of the nonbonded electron pair on nitrogen, as shown in the structure of *N,N*-dimethylaniline in Fig. 5.2(a),

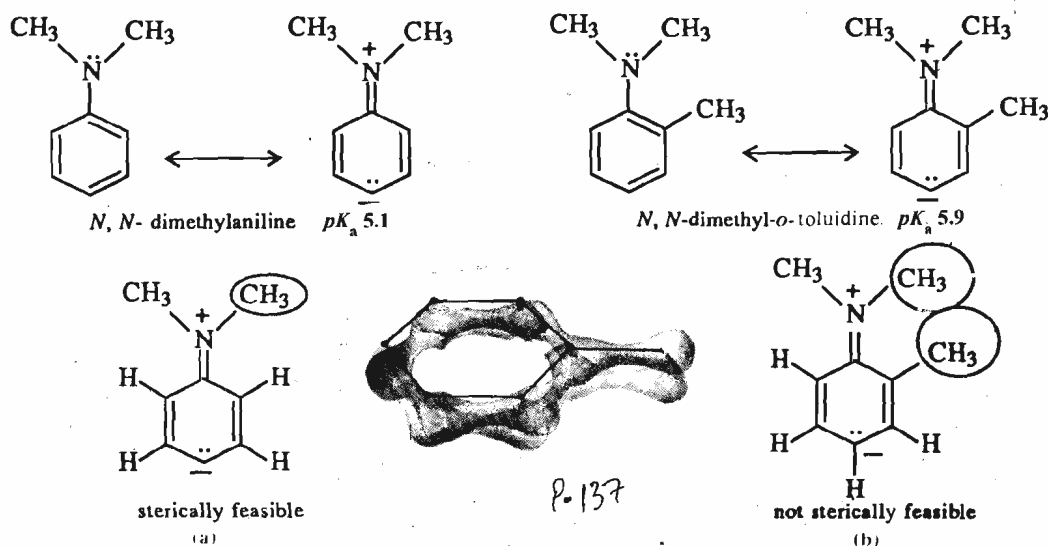

Fig. 5.2 : a) Delocalisation of nonbonded electrons on nitrogen into aromatic ring in *N,N*-dimethylaniline. b) Such a delocalisation is not possible in *N,N*-dimethyl-*o*-toluidine.

requires that the  $p$ -orbital of nitrogen and those of the aromatic ring should be coplanar. Such coplanarity is inhibited in the case  $N,N$ -dimethyl- $o$ -toluidine due to the presence of the *ortho* methyl group, as shown in Fig. 5.2(b). Therefore, in this molecule the electron pair is not delocalised but is available for bonding with the proton which makes this molecule more basic than  $N,N$ -dimethylaniline. This type of steric effect is known as *steric inhibition of resonance*.

Remember that the *steric hindrance* affects the molecular reactivity not by increasing or decreasing the electron availability but due to spatial congestion. Therefore, it is different from electronic effects.

## Activity

Make models of primary, secondary and tertiary amines and compare the steric hindrance observed in these molecules.

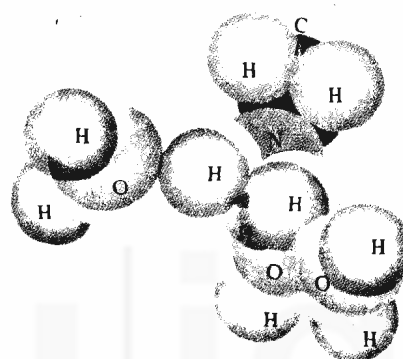
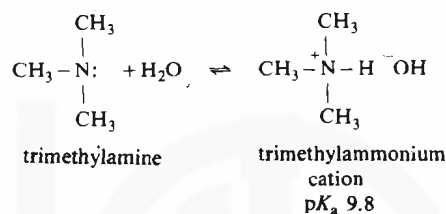

methylammonium ion  
hydrogen bonding with  
three water molecules

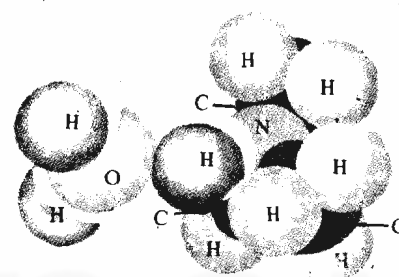

trimethylammonium ion  
hydrogen bonding with  
only one water molecule

Fig. 5.3 : A comparison of the solvation of trimethylammonium and methylammonium ions.

It is thus least stabilised by solvation, leading to the lower basicity of trimethylamine in water as compared to dimethylamine and methylamine. However, in the gas phase or nonaqueous media, the electron-donating inductive effect of a methyl group makes trimethylamine the most basic among methylamines. Let us now study what is solvation and the role of solvent on the reactivity of the molecules.

The presence of a solvent in acid-base reactions leads to the solvation of the ionised species which are the conjugate acid and the conjugate base when we are dealing with Brønsted acids and bases. Solvation refers to the interaction of the dissolved species and solvent molecules wherein several solvent molecules surround the dissolved species by forming a **solvent shell** or **solvent cage** around it, as shown below:

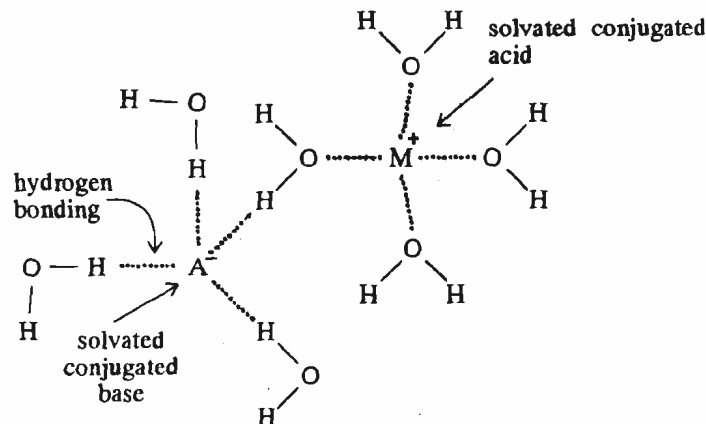

The greater the solvation, the greater is the delocalisation of the charge on the species. Thus, increased solvation increases the dissociation of an acid or a base by increasing the stability of the ions.

These interactions are particularly important when water is used as a solvent where

the hydrogen bonding plays an important role in solvating the anions. The high dielectric constant of water also helps in the dissociation of the acids. Thus, the ionisation and the acidity of a substance increases with the increase in the dielectric constant of the solvent. This is illustrated in Table 5.7.

Table 5.7 : Effect of solvent on  $pK_a$  of ethanoic acid at 298 K.

Solvent	$pK_a$
Benzene	almost unionised
82% Dioxane – 18% Water	10.14
70% Dioxane – 30% Water	8.32
45% Dioxane – 55% Water	6.31
20% Dioxane – 80% Water	5.29
Water	4.76

Thus, as the percentage of water in the solvent system increases, the  $pK_a$  value of the acid decreases.

Water is a peculiar solvent as it can behave both as an acid as well as a base. But its use has a limitation in the sense that some organic compounds are not soluble in it.

Having discussed the various aspects of acids and bases, let us now focus our attention on an internal acid-base process called *tautomerism*.

## 5.5 TAUTOMERISM

The term *tautomerism* designates a rapid and reversible interconversion of isomers which are related to each other with the actual movement of electrons as well as of one or more atoms. Such isomers are called **tautomers**. Thus, tautomerism is a chemical reaction and is to be differentiated from resonance in which the nuclei do not move. It is, therefore, represented by the equilibrium sign ( $\rightleftharpoons$ ) between the tautomers. Tautomers which differ from each other only in the location of a hydrogen atom and a double bond are called **proton tautomers**. Table 5.8 shows some examples of proton tautomers.

Table 5.8 : Some examples of Proton tautomers.

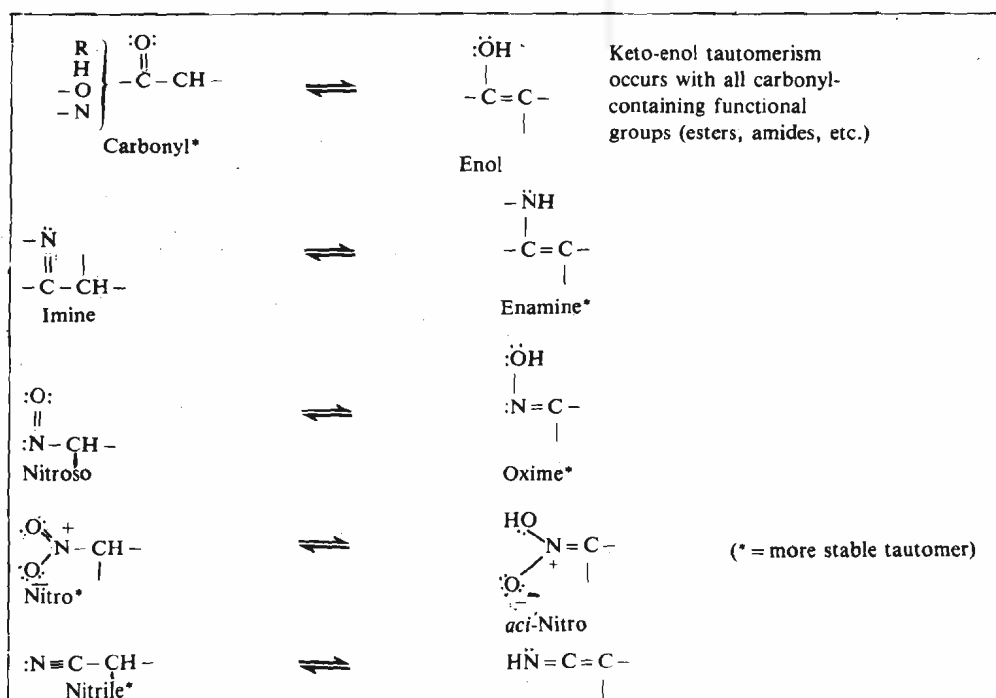

In contrast to resonance structures, tautomers are real compounds and are capable of independent existence.

*enol* has its origin from *ene + ol*.

In *keto-enol tautomers*, the *keto* form is usually the more stable form and, therefore, it predominates at equilibrium.

The mechanism of *enolisation* involves solvent mediated proton transfer steps rather than a direct intramolecular jump of the proton from carbon to oxygen.

A particular example of tautomerism involving the ketones as carbonyl compounds is called **keto-enol tautomerism** and is represented below :

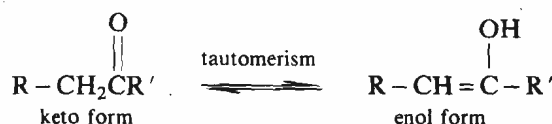

The keto-enol tautomerism is of enormous importance as you will study later in this course and also in the Organic Reactions Mechanism course.

Proton tautomerism in some cases leads to the formation of a ring in one of the tautomers. Such a tautomerism is called as **ring-chain tautomerism** and is illustrated below :

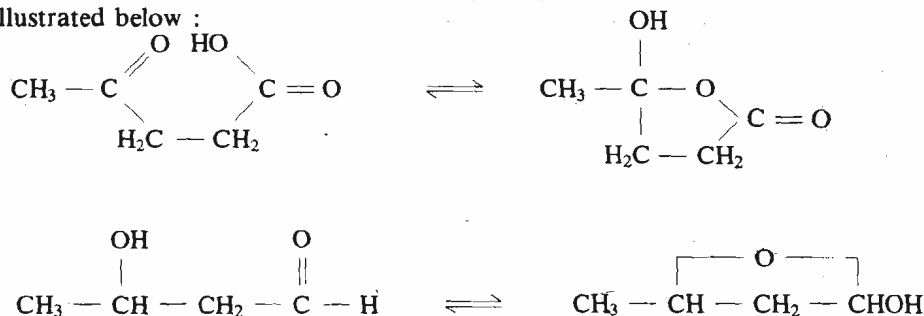

Another kind of tautomerism, known as **valence tautomerism** involves a shift in interatomic distances within a molecule, without the separation of any atom from the rest of the molecule, as an intermediate stage. This kind of tautomerism occurs as a result of movement of valence electrons of the molecule. An example of valence tautomerism is shown below :



cyclooctatetraene

The valence tautomerism may appear similar to resonance but remember that the two are different. The difference is that the valence tautomerism involves making and breaking of  $\sigma$  and  $\pi$  bonds while, in resonance only the  $\pi$  electrons or the nonbonding electrons shift and the  $\sigma$  framework of the molecule is not disturbed. Some other differences between tautomerism and resonance are as follows:

- i) Tautomerism may involve a change in the hybridisation of atoms which may result in a change in the shape of the molecule. While in resonance there is no such change in the hybridisation and geometry of the molecule.
- ii) The tautomers have a physical reality while the resonance structures are imaginary.
- iii) Tautomerism involves an equilibrium between two or more tautomers. On the other hand, the resonance implies that the actual structure of the molecule is the *weighted average* of various resonance contributors and not a mixture of them.

## 5.6 SUMMARY

In this unit, you studied that,

- Many reactions of organic compounds can be classified as acid-base reactions. Therefore, the study of acids and bases is important for understanding the organic reactions.
- According to Brønsted-Lowry definition, an acid is a proton donor and a base is a proton acceptor.
- Lewis definition classifies acids as electron pair acceptors and bases as electron pair donors.
- The acidities of Brønsted acids can be expressed in terms of their  $pK_a$  values.
- A strong acid has a weak conjugate base and a weak acid has a strong conjugate base and vice versa.



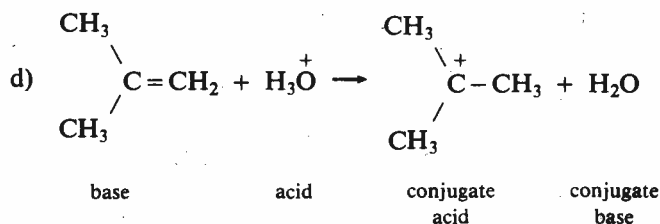
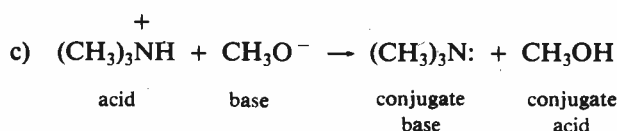
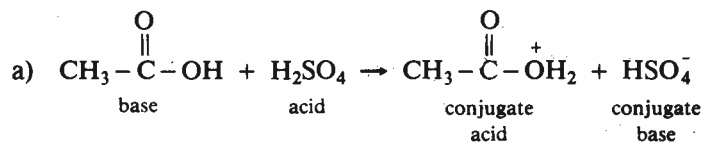

2. a) Acid  $\text{HA}_2$  having the lower  $\text{p}K_a$  value is stronger than acid  $\text{HA}_1$  having higher  $\text{p}K_a$  value.
- b) Since  $\text{HA}_2$  is stronger acid, therefore,  $\text{A}_2^-$  is the weaker base as compared to  $\text{A}_1^-$ . Thus, in an acid-base reaction between  $\text{Na}^+\text{A}_1^-$  and  $\text{HA}_2$  which is shown below;



the stronger base  $\text{A}_1^-$  will abstract the proton from the acid  $\text{HA}_2$  and the equilibrium will lie towards the right to yield  $\text{HA}_1$  and  $\text{Na}^+\text{A}_2^-$ .

3. a) The decreasing order of acidities is,
- $\text{NCCH}_2\text{COOH} > \text{NCCH}_2\text{CH}_2\text{CH}_2\text{COOH} > \text{CH}_3\text{COOH}$ . Since the  $-\text{CN}$  group has  $-I$  effect which increases the acidity of  $\text{NCCH}_2\text{COOH}$  and  $\text{NCCH}_2\text{CH}_2\text{CH}_2\text{COOH}$  as compared to ethanoic acid. But the  $-I$  effect of the  $-\text{CN}$  group decreases with the distance, therefore,  $\text{NCCH}_2\text{CH}_2\text{CH}_2\text{COOH}$  is less acidic than  $\text{NCCH}_2\text{COOH}$ .
  - The compounds have the following order of the acidities:  

$$\text{CH}(\text{NO}_2)_3 > \text{CH}_2(\text{NO}_2)_2 > \text{CH}_3\text{NO}_2$$
 As the  $-\text{NO}_2$  group is strongly electron withdrawing, the acidity increases with the increase in the number of these substituents.
  - $\text{HOOC}\underset{1}{\text{COOH}} > \text{CH}_3\underset{2}{\text{COOH}} > \overset{-}{\text{O}}\underset{3}{\text{COOH}}$

The  $\text{COOH}$  group is  $-I$  type. Hence, it increases the acidity in case of  $\text{HOOC}\text{COOH}$  as compared to  $\text{CH}_3\text{COOH}$ . But, in case of  $\overset{-}{\text{O}}\text{COOH}$ , the removal of a proton is difficult because it is a negatively charged species. Hence, it is less acidic as compared to  $\text{CH}_3\text{COOH}$ .

- b) i) The basicities decrease in the following order:



As the methyl group is electron donating, it increases the basicity in case of  $N$ -methylaniline as compared to aniline. The basicity further increases in  $N,N$ -dimethylaniline due to the increase in the number of methyl groups.

- ii) The decreasing order of basicities is as shown below:

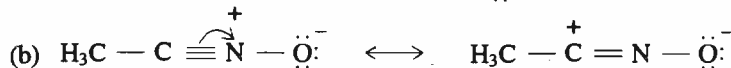
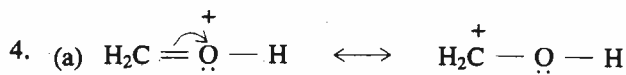
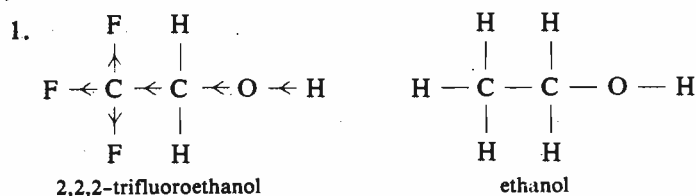

Since the methyl group has  $+I$  effect, it increases the basicity of  $\text{CH}_3\text{NH}_2$  as compared to  $\text{NH}_3$ . But, the substitution of an  $-\text{OH}$  group in  $\text{NH}_3$  decreases its basicity because it has  $-I$  effect.

**Terminal Questions**

The three strong electron withdrawing fluorine atoms (–I groups) increase the acidity of 2,2,2-trifluoroethanol as compared to ethanol.

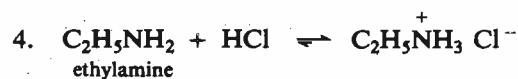
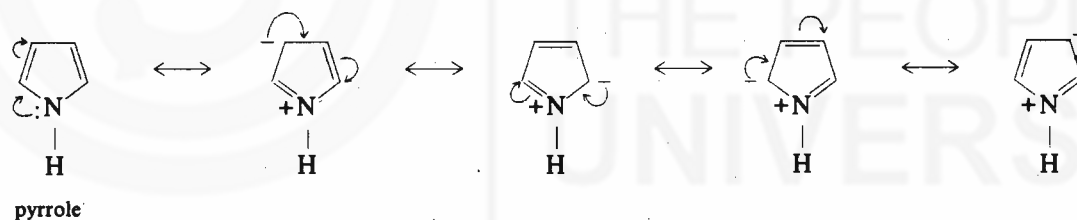
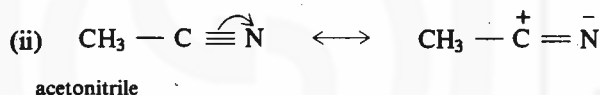
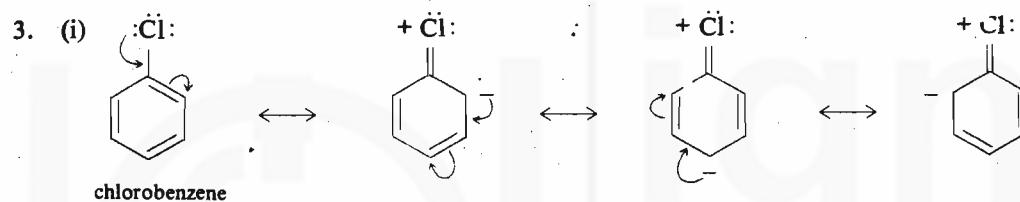
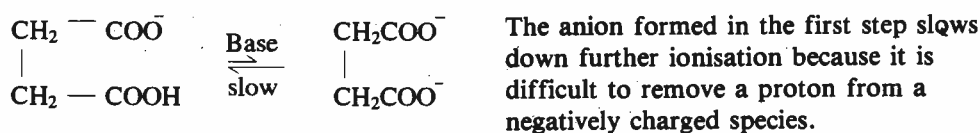
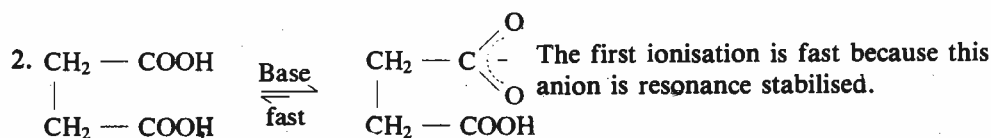

5. Only (a) shows resonance structures; (b), (c) and (d) are tautomers.

**Further Reading**

1. *Organic Chemistry, 6th Ed.*, By R.T. Morrison and R.N. Boyd, Prentice-Hall of India Pvt. Ltd.
2. *Text book of Organic Chemistry, 2nd Ed.*, By Lloyd N. Ferguson, Affiliated East-West Press Pvt. Ltd.
3. *Organic Chemistry, Vol. I and II* By S.M. Mukherji, S.P. Singh and R.P. Kapoor, Wiley Eastern Ltd.
4. *Text book of Organic Chemistry, 24th Ed.*, By P.L. Soni and H.M. Chawla, Sultan Chand and Sons.

## INDEX

- $\pi \rightarrow \pi^*$  Transitions, 100
- $\sigma \rightarrow \sigma^*$  Transitions, 100
- $\beta$  - Carotene, 102
- $\lambda_{\max}$ , 101
  - of Conjugated Systems, 102
- 1,2 - Dimethylcyclohexane, 85
- 1,3 - Dimethylcyclohexane, 86
- 1,4 - Dimethylcyclohexane, 87
- 2-Octanol, 51
  - Physical properties of, 51
- Absolute Ethanol, 103
- Absorbance, 101
- Acetylene, 17
  - Hybridisation, 17
- Achiral, 51
- Acidity Constant, 124
- Acids and Bases, 122.
  - Arrhenius, 122
  - Bronsted - Lowry, 122
  - Lewis, 123
- Angle Strain, 80
- Anomalous Dispersion, 70
- Aromatic, 21
- Asymmetric Centre, 52
- Asymmetric Synthesis, 74
  - Absolute, 74
  - Partial, 74
- Auxochromes, 102
- Axial Hydrogens, 81
- Base peak, 117
- Basicity Constant, 126
- Bathochromic Shift, 103
- Beer - Lambert Law, 102
- Biot, 50
- Boiling Point, 95
- Butane
  - Anti Conformation, 79
  - Eclipsed Conformation, 79
  - Gauche Conformation, 79
- Cahn - Ingold - Prelog sequence rules, 43
  - E* - isomer, 43
  - Z* - isomer, 43
- Carbocation, 71
- Characteristic Infrared Absorption Bands, 106
- Chemical Exchange, 114
- Chemical shift, 112
- Chemically Equivalent Protons, 112
- Chiral Centre, 52
- Chiral, 51
- Chirality, 51
- Chromophores, 101
- Configuration, 61
  - Absolute, 70
  - of (+)-2- Butanol, 69
  - of 2,3 - Dichlorobutane, 70
  - of D-(+)- Glyceraldehyde, 69
  - Relative, 67
- Configurational Notations, 66
  - D, L Notation, 66
  - R, S Notation, 67
- Conformational Analysis, 78
- Conformational Isomers, 77
  - of Butane, 79
  - of Ethane, 78
- Conformations
  - Boat, 81
  - Chair, 81
  - of Cyclic Systems, 80
  - of Cyclohexane, 81
  - of Disubstituted Cyclohexane Derivatives, 85
  - of Monosubstituted Cyclohexane Derivatives, 84
  - Twist Boat or Skew Boat, 83
- Conformations, 77
- Conjugate Acid-Base Pair, 122
- Coupling Constant, 114
- Covalent Bond, 9
  - Bond Angle, 10
  - Bond Dissociation Energy, 9
  - Bond Energy, 9
- Dextrorotatory, 50
- Diastereoisomers, 53
- Dielectric Constant, 97
- Dihedral Angle, 77
- Eclipsed Conformation of Ethane, 78
- Electromagnetic Radiation, 99
- Electromagnetic Spectrum, 99
- Electronic Effect, 127
- Electronic Spectroscopy, 100
- Elements of symmetry, 54
  - Alternating axis of symmetry, 55
  - Axis of symmetry, 55
  - Centre of symmetry, 55
  - Plane of symmetry, 54
- Enantiomers
  - of Lactic Acid, 52
  - of *N* - Methyl ethanamine, 93, Block 4
- Equatorial Hydrogens, 81
- Ethane, 14
  - Hybridisation, 15
- Far Infrared, 104
- Fingerprint Region, 107
- Fischer Projection Formulas, 61
  - Rules for interconversion of, 64
- Flagpole Hydrogens, 82
- Force Constant, 105
- Fragmentation Reactions, 115
- Fumaric Acid, 48
- Functional Group Classification, 18
  - Functional group (s), 18
- Geometrical Isomers
  - Characterisation of, 46
  - Physical properties of, 46
- Heat of Combustion, 80, 81